

INSTALLATION & OPERATING INSTRUCTIONS

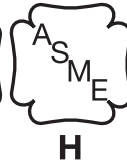

Models 992B-2342B
Types H, WH & P



WARNING: If these instructions are not followed exactly, a fire or explosion may result causing property damage, personal injury or death.

FOR YOUR SAFETY: Do not store or use gasoline or other flammable vapors and liquids or other combustible materials in the vicinity of this or any other appliance. To do so may result in an explosion or fire.

WHAT TO DO IF YOU SMELL GAS:

- Do not try to light any appliance.
- Do not touch any electrical switch; do not use any phone in your building.
- Immediately call your gas supplier from a neighbor's phone. Follow the gas supplier's instructions.
- If you cannot reach your gas supplier, call the fire department.

Installation and service must be performed by a qualified installer, service agency or the gas supplier.

This manual should be maintained in legible condition and kept adjacent to the heater or in another safe place for future reference.

Raypak[®]
A Rheem[®] Company

Rev. 12 reflects the following:

Changes to: Model Types on page 1, Fig. 5 on page 9, “System Design” on page 16, Fig. 13 on page 18, “Changing the Flue Outlet” on page 29, Table S on page 48, carbon dioxide levels and igniter amperage on page 62.

Additions: Fig. 28 on page 29, Wiring Diagrams on pages 53-54

Deletions: None

CONTENTS

WARNINGS	4	Venting Installation Tips	29
BEFORE INSTALLATION	5	Venting Configurations	30
Product Receipt	5	Outdoor Installation	35
Model Identification	5	Controls	35
Ratings and Certifications	5	Heater Sequence of Operation	36
Installations at Elevation	5	87%-Efficiency Boilers –	
Component Locations	6	Special Instructions	48
General Information	7	Wiring Diagrams	53
GENERAL SAFETY	8	START-UP	55
Time/Temperature Relationships in		Pre Start-up	55
Scalds	8	Start-up	56
INSTALLATION	9	OPERATION	59
Installation Codes	9	Lighting Instructions	59
Equipment Base	9	To Turn Off Gas To Appliance	59
Stacking	9	TROUBLESHOOTING	60
Clearances	11	MAINTENANCE	61
Combustion and Ventilation Air	12	Suggested Minimum	
Conventional Combustion Air Supply	13	Maintenance Schedule	61
Water Piping	14	Preventative Maintenance Schedule	61
Hydronic Heating	16	APPENDIX	63
Pool Heating	18	Inside Air Contamination	63
Gas Supply	22	WARRANTIES	64
Electrical Power Connections	24	Type H and WH	64
Field Wiring Connection	25	Type P	65
Venting	27	Important Instructions for the	
Changing the Flue Outlet	29	Commonwealth of Massachusetts	66
		Start-up Checklist	67

WARNINGS

Pay Attention to These Terms

DANGER:	Indicates the presence of immediate hazards which will cause severe personal injury, death or substantial property damage if ignored.
WARNING:	Indicates the presence of hazards or unsafe practices which could cause severe personal injury, death or substantial property damage if ignored.
CAUTION:	Indicates the presence of hazards or unsafe practices which could cause minor personal injury or product or property damage if ignored.
NOTE:	Indicates special instructions on installation, operation, or maintenance which are important but not related to personal injury hazards.

DANGER: Make sure the gas on which the heater will operate is the same type as that specified on the heater rating plate.

WARNING: Should overheating occur or the gas supply valve fail to shut, do not turn off or disconnect the electrical supply to the heater. Instead, shut off the gas supply at a location external to the heater.

WARNING - CALIFORNIA PROPOSITION 65: This product contains chemicals known to the State of California to cause cancer, birth defects or other reproductive harm.

WARNING: To minimize the possibility of improper operation, serious personal injury, fire, or damage to the heater:

- Always keep the area around the heater free of combustible materials, gasoline, and other flammable liquids and vapors.
- Heater should never be covered or have any blockage to the flow of fresh air to the heater.

WARNING: Do not use this heater if any part has been under water. Immediately call a qualified service technician to inspect the heater and to replace any part of the control system and any gas control which has been under water.

WARNING: All venting types must be of the same material or product throughout the entire exhaust installation to ensure proper securing and sealing.

WARNING: Both natural gas and propane have an odorant added to aid in detecting a gas leak. Some people may not physically be able to smell or recognize this odorant. If you are unsure or unfamiliar with the smell of natural gas or propane, ask your local gas supplier. Other conditions, such as "odorant fade," which causes the odorant to diminish in intensity, can also hide, camouflage, or otherwise make detecting a gas leak by smell more difficult.

WARNING: UL recognized fuel gas detectors are recommended in all enclosed propane and natural gas applications wherein there is a potential for an explosive mixture of fuel gas to accumulate and their installation should be in accordance with the detector manufacturer's recommendations and/or local laws, rules, regulations, or customs.

WARNING: Risk of electrical shock. More than one disconnect switch may be required to deenergize the equipment before servicing.

CAUTION: Operation of this heater in low-temperature systems requires special piping. Harmful internal condensation will occur if the inlet water temperature does not exceed 105°F. Warranty claims will be denied when condensation occurs.

CAUTION: If this heater is to be installed above radiation level, it must be provided with a low water cut-off device at the time of heater installation.

CAUTION: If this heater is to be installed in a negative or positive pressure equipment room, there are special installation requirements. Consult factory for details.

BEFORE INSTALLATION

Raypak strongly recommends that this manual be reviewed thoroughly before installing your Hi Delta heater. Please review the General Safety information before installing the heater. Factory warranty does not apply to heaters that have been improperly installed or operated. (Refer to the warranty at the back of this manual.) Installation and service must be performed by a qualified installer, service agency or gas supplier. If, after reviewing this manual, you still have questions which this manual does not answer, please contact the manufacturer or your local Raypak representative.

Thank you for purchasing a Raypak product. We hope you will be satisfied with the high quality and durability of our equipment.

Product Receipt

On receipt of your heater it is suggested that you visually check for external damage to the shipping crate. If the crate is damaged, make a note to that effect on the Bill of Lading when signing for the shipment. Remove the heater from the shipping packaging. Report any damage to the carrier immediately.

On occasion, items are shipped loose. Be sure that you receive the correct number of packages as indicated on the Bill of Lading.

Claims for shortages and damages must be filed with the carrier by consignee. Permission to return goods must be received from the factory prior to shipping. Goods returned to the factory without an authorized Returned Goods Receipt number will not be accepted. All returned goods are subject to a restocking charge.

When ordering parts, you must specify the model and serial number of the heater. When ordering under warranty conditions, you must also specify the date of installation.

Purchased parts are subject to replacement only under the manufacturer's warranty. Debits for defective replacement parts will not be accepted and will be replaced in kind only per Raypak's standard warranties.

Model Identification

The model identification number and heater serial number are found on the heater rating plate located on the lower right outside jacket of the heater. The model

number will have the form H9 1262B or similar depending on the heater size and configuration. The letter(s) in the first group of characters identifies the application (H = Hydronic Heating, WH = Domestic Hot Water (DHW), P = Pool). The number which follows identifies the firing mode (1 or 4 = on-off, 3 = 2-stage, 8 = 3-stage and 9 = 4-stage). The second group of characters identifies the size of the heater (four numbers representing the approximate MBTUH input), and, where applicable, a letter, indicating the manufacturing series. An "E" suffix indicates 87% efficiency (Category II or IV venting) ("H" stamped boilers only).

Ratings and Certifications

Standards:

- ANSI Z21.13 · CSA 4.9 - latest edition, Gas-Fired Hot Water Boilers
- CAN 3.1 - latest edition, Industrial and Commercial Gas-Fired Package Boilers
- ANSI Z21.56 · CSA 4.7 - latest edition Gas-Fired Pool Heaters
- ANSI Z21.10.3 · CSA 4.3 - latest edition Gas Water Heaters
- CSA certified compliance with California AB1953 and Vermont Legislative Act 193 requirements.

All Raypak heaters are National Board registered, and design-certified and tested by the Canadian Standards Association (CSA) for the U.S. and Canada. Each heater is constructed in accordance with Section IV of the American Society of Mechanical Engineers (ASME) Heater Pressure Vessel Code and bears the ASME stamp. The heater also complies with the latest edition of ASHRAE 90.1 Standard.

WARNING: Altering any Raypak pressure vessel by installing replacement heat exchangers, tube bundle headers, or any ASME parts not manufactured and/or approved by Raypak will instantly void the ASME and CSA ratings of the vessel and any Raypak warranty on the vessel. Altering the ASME or CSA ratings of the vessel also violates national, state, and local approval codes.

Installations at Elevation

Rated inputs are suitable for up to 4,500 ft elevation without de-rating. Consult the factory for installations at altitudes over 4,500 ft above sea level. Orifices are not affected.

Component Locations

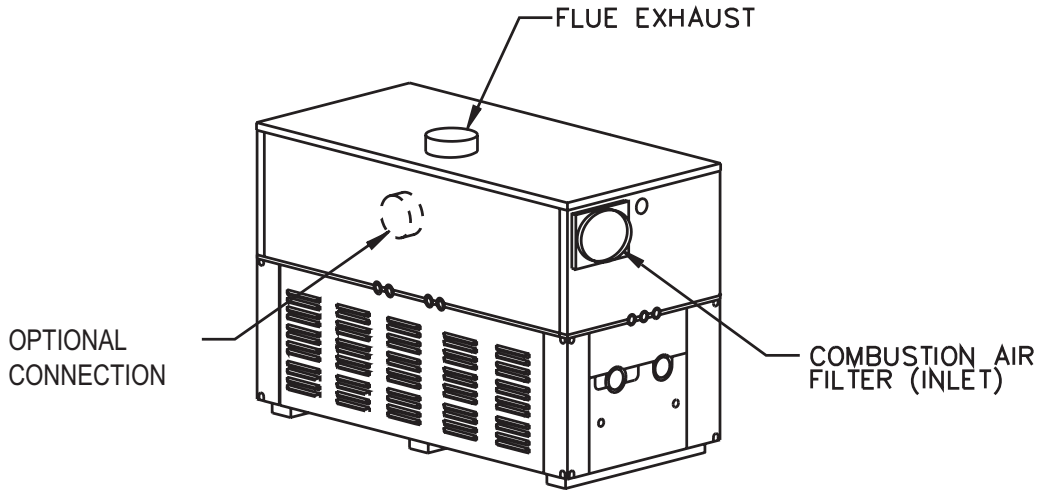

Fig. 1: Component Locations – Back

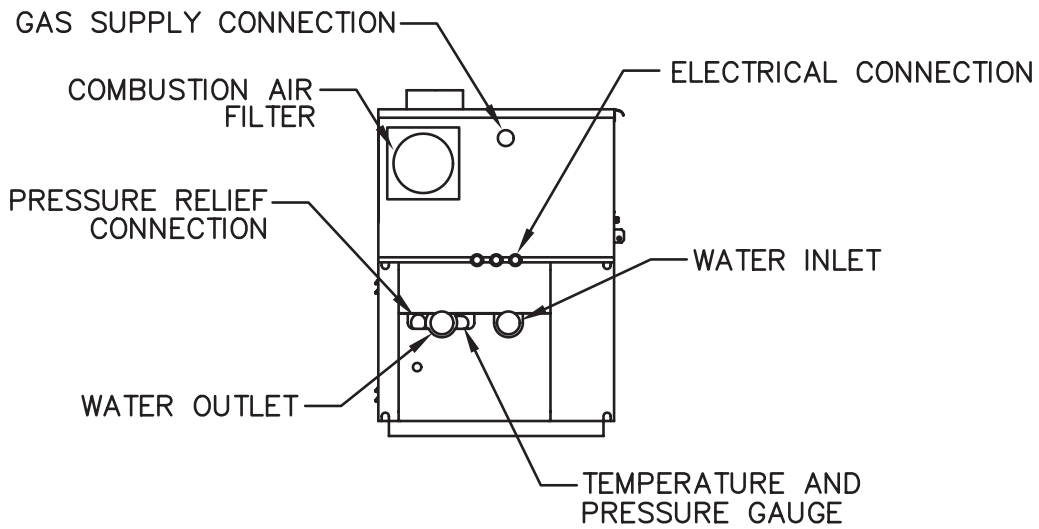
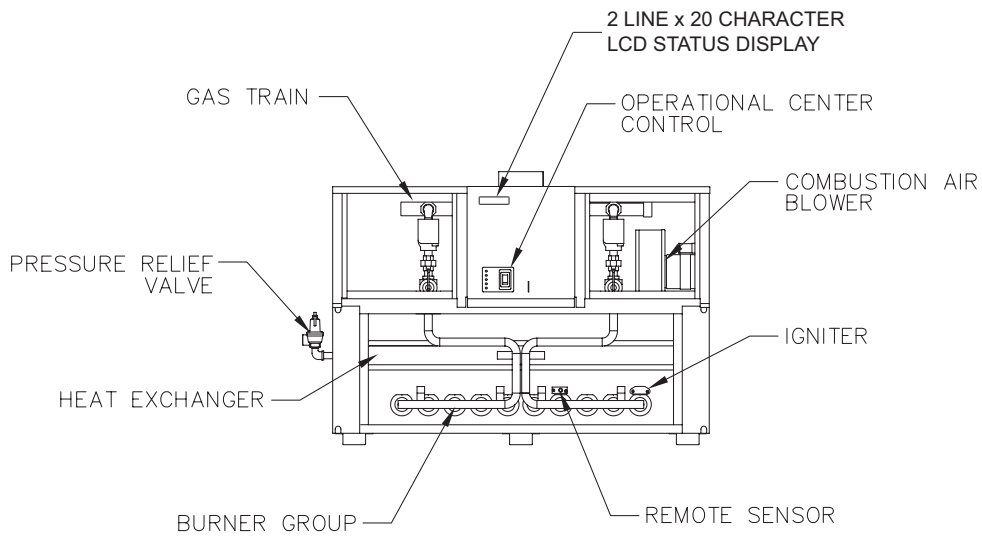

Fig. 2: Component Locations – Left Side



Panels removed for clarity
Fig. 3: Component Locations – Front

General Information

Model No.	Quantity of			Vent Size (in.)	
	Burners	Gas Valves	Blowers	Flue	Intake
992B	11	2 + 1*	2	10	10
1262B	14	3 + 1*	2	12	10
1532B	17	4	2	12	10
1802B	20	4	2	14	10
2002B	23	5	3	14	10
2072B	23	5	3	14	10
2342B	26	5	3	16	10

*Hidden solenoid valve located inside of air plenum.

Table A: Basic Data

Model No.	Burners per Valve					Stages				% Fire at Stage			
	1	1A	2	3	4	1	2	3	4	1	2	3	4
992B	6		3	2		1	1, 2	1, 2, 3		54	82	100	
1262B	5		3	3	3	1	1,2	1, 2, 3	1, 2, 3, 4	36	57	79	100
1532B	6		4	4	3	1	1,2	1, 2, 3	1, 2, 3, 4	35	59	82	100
1802B	6		4	5	5	1	1,2	1, 2, 3	1, 2, 3, 4	30	50	75	100
2002B	4	5	5	5	4	1, 1A	1, 1A, 2	1, 1A, 2, 3	1, 1A, 2, 3, 4	39	61	83	100
2072B	4	5	5	5	4	1, 1A	1, 1A, 2	1, 1A, 2, 3	1, 1A, 2, 3, 4	39	61	83	100
2342B	5	6	5	5	5	1, 1A	1, 1A, 2	1, 1A, 2, 3	1, 1A, 2, 3, 4	42	62	81	100

Table B: Manifold Data

GENERAL SAFETY

To meet commercial hot water use needs, the high limit safety control on this water heater is adjustable up to 210°F. However, water temperatures over 125°F can cause instant severe burns or death from scalds. When supplying general purpose hot water, the recommended initial setting for the temperature control is 125°F.

Safety and energy conservation are factors to be considered when setting the water temperature on the thermostat. The most energy-efficient operation will result when the temperature setting is the lowest that satisfies the needs of the application.

Water temperature over 125°F can cause instant severe burns or death from scalds. Children, disabled and elderly are at highest risk of being scalded.

- Feel water before bathing or showering.
- Temperature limiting valves are available.

NOTE: When this water heater is supplying general purpose hot water for use by individuals, a thermostatically controlled mixing valve for reducing point of use water temperature is recommended to reduce the risk of scald injury. Contact a licensed plumber or the local plumbing authority for further information.

Maximum water temperatures occur just after the heater's burner has shut off. To determine the water temperature being delivered, turn on a hot water faucet and place a thermometer in the hot water stream and read the thermometer.

DANGER

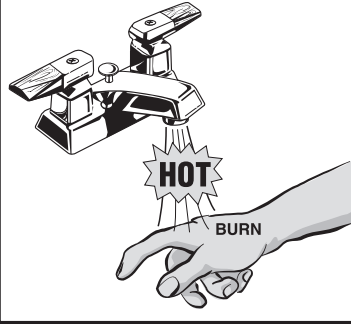

Water temperature over 125°F can cause instant severe burns or death from scalds.

Children, disabled, and elderly are at highest risk of being scalded.

See instruction manual before setting temperature at water heater.

Feel water before bathing or showering.

Temperature limiting valves are available, see manual.

Time/Temperature Relationships in Scalds

The following chart details the relationship of water temperature and time with regard to scald injury and may be used as a guide in determining the safest water temperature for your applications.

Water Temp.	Time to Produce Serious Burn
120°F	More than 5 minutes
125°F	1-1/2 to 2 minutes
130°F	About 30 seconds
135°F	About 10 seconds
140°F	Less than 5 seconds
145°F	Less than 3 seconds
150°F	About 1-1/2 seconds
155°F	About 1 second

Table courtesy of The Shriners Burn Institute

Table C: Time to Produce Serious Burn

The temperature of the water in the heater can be regulated by using an optional temperature controller. To comply with safety regulations, the temperature controller is set at the lowest setting when shipped from the factory. Raypak heaters are manufactured using either mechanical or digital controllers (sales order "B" options).

To adjust the water temperature of a mechanical controller, insert a small straight screwdriver into the adjustment screw on the front of temperature controller and turn the wheel to the desired setting (See Fig. 4.). To adjust the water temperature of a digital controller, consult your controller's operating manual.

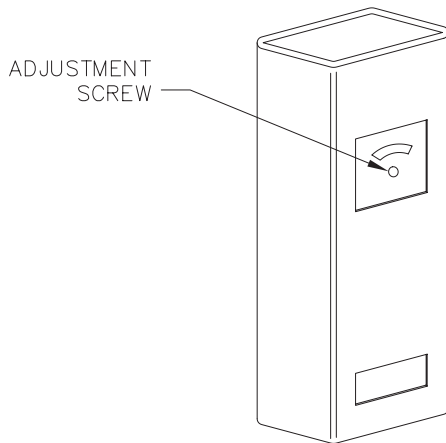

Fig. 4: Temperature Controller (Mechanical)

CAUTION: Hotter water increases the risk of scalding! There is a hot water scald potential if the thermostat is set too high.

INSTALLATION

Installation Codes

Installations must follow these codes:

- Local, state, provincial, and national codes, laws, regulations and ordinances
- National Fuel Gas Code, ANSI Z223.1/NFPA 54 – latest edition (NFGC)
- National Electrical Code, ANSI/NFPA 70 - latest edition (NEC)
- Standard for Controls and Safety Devices for Automatically Fired Boilers, ANSI/ASME CSD-1, when required (CSD-1)
- For Canada only: CAN/CSA B149 Installation Code (B149) and CSA C22.1 C.E.C. Part 1 (C22.1)

Equipment Base

The heater should be mounted on a level, structurally sound surface. The heater is approved for installation on a combustible surface but must NEVER be installed on carpeting. Gas-fueled equipment installed in enclosed parking garages must be located at least 18 in. above the floor.

Stacking

Hi Delta units can be stacked two units high with an optional stacking rack. A stacking kit (sales order option X-1) is available from Raypak for this type of installation. For installations above grade, a reinforcing kit (sales order option X-2) may also be required.

CAUTION: The heaters should be located in an area where water leakage will not result in damage to the area adjacent to the appliances or to the structure. When such locations cannot be avoided, it is recommended that a suitable catch pan, adequately drained, be installed under the appliance. The pan must not restrict air flow.

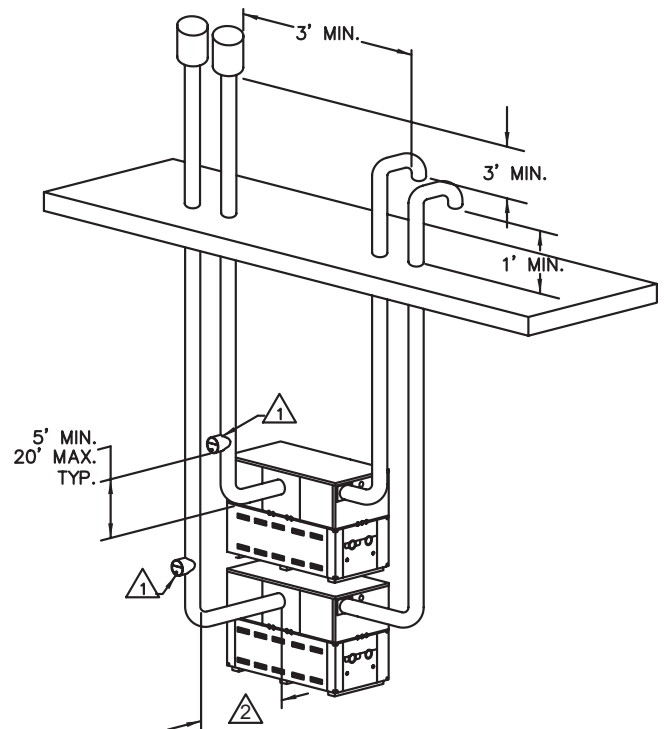

NOTE:

⚠ USE A SINGLE ACTING BAROMETRIC DAMPER IN CATEGORY I, WHEN THE VERTICAL RISE EXCEEDS 25 FEET.

⚠ PER NATIONAL FUEL GAS CODE (NFGC).

Fig. 5: Typical Stacked Installation

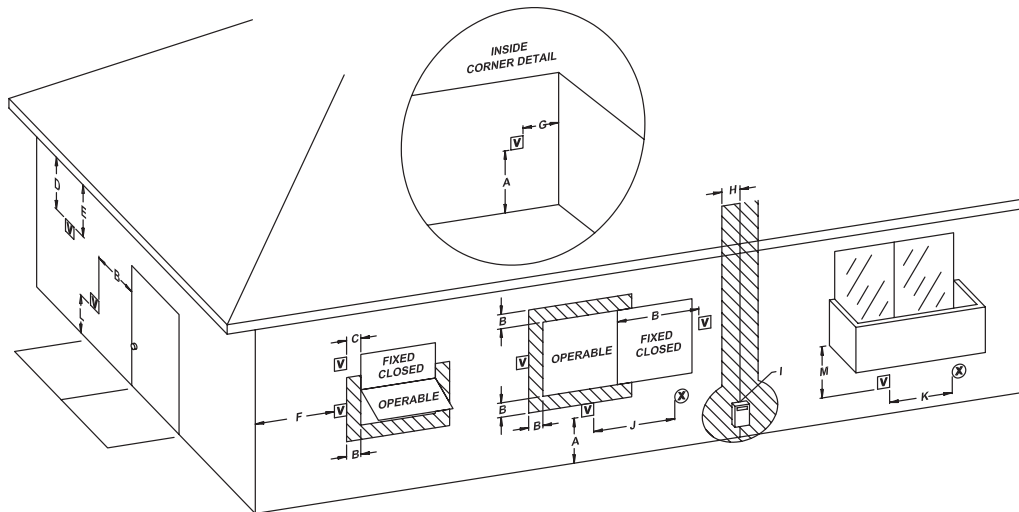

Fig. 6: Minimum Clearances from Vent/Air Inlet Terminations – Indoor and Outdoor Installations

		U.S. Installations¹	Canadian Installations²
A	Clearance above grade, veranda, porch, deck, or balcony	1 ft (30 cm)	1 ft (30 cm)
B	Clearance to window or door that may be opened	4 ft (1.2m) below or to side of opening; 1 foot (30 cm) above opening	3 ft (91 cm)
C	Clearance to permanently closed window	*	*
D	Vertical clearance to ventilated soffit located above the terminal within a horizontal distance of 2 ft (61cm) from the centerline of the terminal	5 ft (1.5m)	*
E	Clearance to unventilated soffit	*	*
F	Clearance to outside corner	*	*
G	Clearance to inside corner	6 ft (1.83m)	*
H	Clearance to each side of center line extended above meter/regulator assembly	*	3 ft (91 cm) within a height 15 ft above the meter/regulator assembly
I	Clearance to service regulator vent outlet	*	6 ft (1.83m)
J	Clearance to non-mechanical air supply inlet to building or the combustion air inlet to any other appliance	4 ft (1.2m) below or to side of opening; 1 ft (30 cm) above opening	3 ft (91 cm)
K	Clearance to mechanical air supply inlet	3 ft (91 cm) above if within 10 ft (3m) horizontally	6 ft (1.83m)
L	Clearance above paved sidewalk or paved driveway located on public property	7 ft (2.13m)	7 ft (2.13m) t
M	Clearance under veranda, porch, deck or balcony	*	12 in. (30 cm) TT

¹ In accordance with the current ANSI Z223.1/NFPA 54 National Fuel Gas Code

² In accordance with the current CAN/CSA-B149 Installation Codes

t Vent terminal shall not terminate directly above sidewalk or paved driveway located between 2 single family dwellings that serves both dwellings

TT Permitted only if veranda, porch, deck, or balcony is fully open on a minimum of two sides beneath the floor and top of terminal and underside of veranda, porch, deck or balcony is greater than 1 ft (30cm)

* Clearances in accordance with local installation codes and the requirements of the gas supplier

Table D: Vent/Air Inlet Termination Clearances

In addition, the heater shall be installed such that the gas ignition system components are protected from water (dripping, spraying, rain, etc.) during appliance operation or service (circulator replacement, control replacement, etc.).

Clearances

Indoor Installations

Heater Side	Minimum Clearance from Combustible Surfaces	Recommended Service Clearance
Floor*	0"	0"
Rear	1"	6"
Water Side	12"	24"
Other Side	1"	24"
Top	1"	6"
Front	Open	24"
Vent	2"	2"

* DO NOT install on carpeting.

Table E: Clearances – Indoor Installations

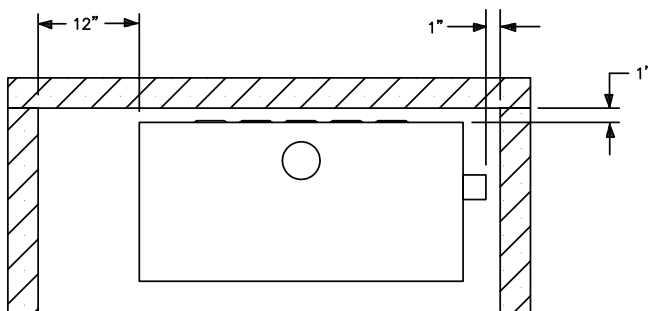

TOP VIEW

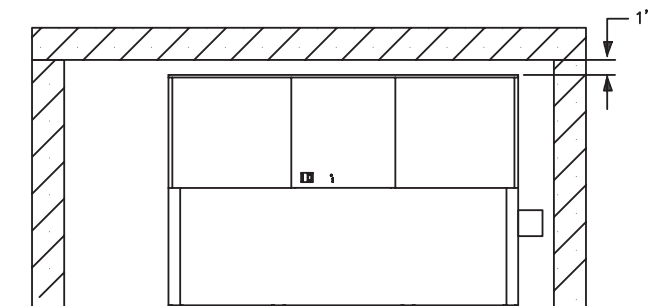

FRONT VIEW

Venting not shown for clarity. Heater must be vented per instructions in this manual

Fig. 7: Minimum Clearances from Combustible Surfaces – Indoor Installations

When installed according to the listed minimum clearances from combustible construction, these heaters can still be serviced without removing permanent structural construction around the heater. However, for ease of servicing, we recommend a clearance of at least 24 in. in front, and at least 12 in. on the water connection side. This will allow the heater to be serviced in its installed location without movement or removal of the heater.

Service clearances less than the minimums may require removal of the heater to service either the heat exchanger or the burner tray. In either case, the heater must be installed in a manner that will enable the heater to be serviced without removing any structure around the heater.

Outdoor Installations

These heaters are design-certified for outdoor installation. Heaters must not be installed under an overhang that is less than 3 ft from the top of the heater. Three sides must be open in the area under the overhang. Roof water drainage must be diverted away from heaters installed under overhangs.

Heater Side	Min. Clearance from Combustible Surfaces	Recommended Service Clearance
Front	Open	24"
Rear	12"	24"
Water Side	36"	36"
Other Side	36"	36"
Top	Unobstructed	36"
Vent	N/A	N/A

Table F: Clearances – Outdoor Installations

These clearances are required when the outdoor vent cap is used. If installing the heater outdoors with a vent stack, the indoor clearances may be utilized.

The combustion air intake hood MUST be used for outdoor installations. The hood is shipped loose and installed on the side of the heater over the filter box at the jobsite.

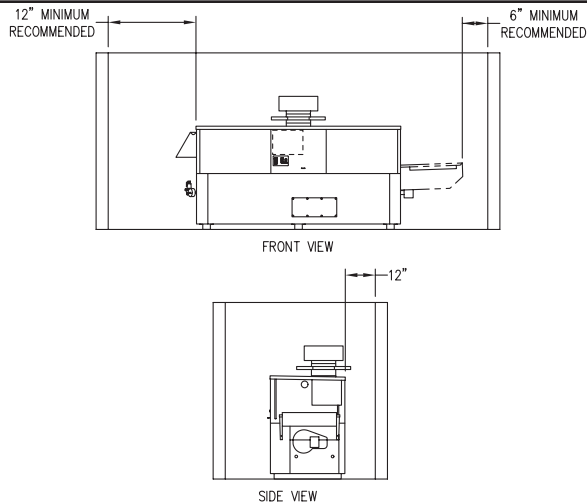

Fig. 8: Minimum Clearances from Combustible Surfaces – Outdoor Installations

Combustion and Ventilation Air

NOTE: Use of the heater in construction areas where fine particulate matter, such as concrete or dry-wall dust, is present may result in damage to the heater that is not covered by the warranty. If operated in a construction environment, a clean source of combustion air must be provided directly to the heater.

Indoor Units

The heater must be supplied with sufficient quantities of non-contaminated air to support proper combustion and equipment ventilation. Combustion air can be supplied via conventional means where combustion air is drawn from the area immediately surrounding the heater, or via direct vent, where combustion air is drawn directly from outside. All installations must comply with the requirements of the NFGC (U.S.) and B149 (Canada), and all local codes.

CAUTION: Combustion air must not be contaminated by corrosive chemical fumes which can damage the heater and void the warranty. (See the Appendix.)

NOTE: It is recommended that the intake vent be insulated to minimize sweating.

Reversing Air Filter

Follow these instructions to change the air duct connection from the left-hand side (standard) to the right-hand side:

1. Remove the four screws and the dust cover from the right-hand side of the heater.
2. Remove the four screws and the air filter bracket from the left-hand side of the heater.
3. Reverse the components and reattach in the new location, making sure that the air filter locking bracket is on the bottom. (The air filter locking bracket is reversible.)

Direct Vent

If outside air is drawn through the intake pipe directly to the unit for combustion:

1. Install combustion air direct vent in accordance with Fig. 31 (horizontal) or Fig. 32 (vertical) of this manual (pages 33 and 34, respectively).
2. Ventilation of the space occupied by the heater(s) is recommended and can be provided by an opening(s) for ventilation air at the highest practical point communicating with the outdoors. The total cross-sectional area should be at least 1 in.² of free area per 20,000 BTUH (111 mm² per kW) of total input rating of all equipment in the room when the opening is communicating directly with the outdoors or through vertical duct(s). The total cross-sectional area should be at least 1 in.² of free area per 10,000 BTUH (222 mm² per kW) of total input rating of all equipment in the room when the opening is communicating with the outdoors through horizontal duct(s). Damage to the equipment due to inadequate ventilation of the space is not a warrantable failure.
3. In cold climates, and to mitigate potential freeze-up, Raypak highly recommends the installation of a motorized sealed damper to prevent the circulation of cold air through the heater during the non-operating hours.

Direct-Ducted Combustion Air

In certain applications it may be desirable to duct the combustion air directly to the heater. This should be done with PVC, CPVC or single-wall galvanized ducting. The duct will attach directly to the collar on the air filter housing located on the side of the heater. The ducting is attached to the air filter housing collar using

three or four sheet metal screws (not supplied) equally distributed around the circumference of the duct. All ducting should be self-supported. The filter housing is not designed to support the air duct.

CAUTION: Use TrueSeal combustion air if damaging airborne contaminants are or will be present in the heater area. See the Appendix regarding air contamination.

TruSeal™ Combustion Air

In certain applications it may be necessary to utilize the TruSeal option (sales order option D-21 or D-22) and duct the combustion air directly to the blower. Combustion air may be ducted directly to the heater by using PVC, CPVC or sealed single-wall galvanized ducting. The duct will attach directly to the air collar located on the side of the heater, using three or four sheet metal screws (not supplied) equally positioned around the circumference of the duct. The screws and duct connection point must be sealed with RTV (not supplied). An in-line intake air filter kit (sales order option D-17) must be installed in the combustion air duct. TruSeal is generally used when damaging contaminants are present in the mechanical room.

TruSeal heater connection points are available as follows:

992B to 1802B	Left side – standard Right side – optional
2002B to 2342B	Right side only

CAUTION: This type of installation is recommended if damaging airborne contaminants are or will be present in the heater area. See the Appendix regarding air contamination.

Conventional Combustion Air Supply

U.S. Installations

All Air from Inside the Building

The confined space shall be provided with **TWO** permanent openings communicating directly with an additional room(s) of sufficient volume so that the combined volume of all spaces meets the criteria for a room large in comparison (NFGC). The total input of all gas utilization equipment installed in the combined

space shall be considered in making this determination. Each opening shall have a minimum free area of 1 in.² per 1,000 BTUH (2,225 mm² per kW) of the total input rating of all gas utilization equipment in the confined space, but not less than 100 in.² (645 cm²). One opening shall commence within 12 in. (305 mm) of the top, and one opening shall commence within 12 in. (305 mm) of the bottom of the enclosure. The minimum dimension of air openings shall be not less than 3 in. (76 mm) in any direction.

All Air from Outdoors

The confined space shall communicate with the outdoors in accordance with one of the methods below. The minimum dimension of air openings shall not be less than 3 in. (76 mm) in any direction. Where ducts are used, they shall be of the same cross-sectional area as the net free area of the openings to which they connect.

- Two permanent openings**, one commencing within 12 in. (305 mm) of the top, and one commencing within 12 in. (305 mm) of the bottom of the enclosure, shall be provided. The openings shall communicate directly, or by ducts, with the outdoors or spaces (crawl or attic) that freely communicate with the outdoors.
 - Where directly communicating with the outdoors or where communicating to the outdoors through vertical ducts, each opening shall have a minimum free area of 1 in.² per 4,000 BTUH (550 mm² per kW) of total input rating of all equipment in the enclosure.
 - Where communicating with the outdoors through horizontal ducts, each opening shall have a minimum free area of 1 in.² per 2,000 BTUH (1,100 mm² per kW) of total input rating of all equipment in the enclosure.
- One permanent opening**, commencing within 12 in. (305 mm) of the top of the enclosure, shall be permitted where the equipment has clearances of at least 1 in. (25 mm) from the sides and back and 6 in. (152 mm) from the front of the appliance. The opening shall directly communicate with the outdoors or shall communicate through a vertical or horizontal duct to the outdoors or spaces that freely communicate with the outdoors, and shall have a minimum free area of:
 - 1 in.² per 3,000 BTUH (740 mm² per kW) of the total input rating of all equipment located in the enclosure, and

- b. Not less than the sum of the areas of all vent connectors in the confined space.

WARNING: Do not use one permanent opening method if the equipment room is under negative pressure conditions or the equipment is common vented with other gas-fired appliances.

Canadian Installations

CAUTION: All combustion air must be drawn from the air outside of the building; the mechanical equipment room must communicate directly with the outdoors.

1. Ventilation of the space occupied by the heater shall be provided by an opening(s) for ventilation air at the highest practical point communicating with the outdoors. The total cross-sectional area of such an opening(s) shall be at least 10% of the area required in 2. and 3. (below), but in no case shall the cross-sectional area be less than 10 in.² (65 cm²).
2. For heaters using a barometric damper in the vent system there shall be a permanent air supply opening(s) having a cross section area of not less than 1 in.² per 7,000 BTUH (320 mm² per kW) up to and including 1 million BTUH, plus 1 in.² per 14,000 BTUH (160 mm² per kW) in excess of 1 million BTUH. This opening(s) shall be either located at or ducted to a point not more than 18 in. (450 mm) nor less than 6 in. (152 mm) above the floor level. The duct can also “goose neck” through the roof. The duct is preferred to be straight down and terminated 18 in. (450 mm) from the floor, but not near piping. This air supply opening requirement shall be in addition to the air opening for ventilation air required in 1. (above).

WARNING: Care must be taken to ensure that the equipment room is not under negative pressure conditions or that the equipment is not common-vented with other gas-fired appliances.

3. For heaters not using a barometric damper in the vent system, and when air supply is provided by natural air flow from outdoors for a power burner and there is no draft regulator, draft hood or similar flue gas dilution device installed in the same space, in addition to the opening for ventilation air required in 1., there shall be a permanent air supply opening(s) having a total cross-sectional area

of not less than 1 in.² for each 30,000 BTUH mm² per kW) of total rated input of the burner(s), and the location of the opening(s) shall not interfere with the intended purpose of the opening(s) for ventilation air referred to in (1). This opening(s) can be ducted to a point not more than 18 in. (450 mm) nor less than 6 in. (152 mm) above the floor level. The duct can also “goose neck” through the roof. The duct is preferred to be straight down 18 in. (450 mm) from the floor, but not near piping.

4. Refer to B149 Installation code for additional information.

Water Piping

NOTE: For 87%-efficiency boilers, see special instructions on page 48.

General

The heater should be located so that any water leaks will not cause damage to the adjacent area or structures.

CAUTION: This heater requires forced water circulation when the burner is operating. See Table G and Table H for minimum and maximum flow rates and water pump selection. The pump must be interlocked with the heater to prevent heater operation without water circulation.

NOTE: Minimum pipe size for in/out connections is 2 ½ NPT. Verify proper flow rates and ΔT as instructed in this manual.

Reversing Water Connections

Follow these instructions to change the water connections from the left-hand side (standard) to the right-hand side.

1. Disconnect all electrical power from the heater (if applicable).
2. Label all electrical connections and conduit lines. This may include the flow switch, low water cut-off probe and/or pump.
3. Disconnect or isolate the main gas pipe from the heater (if applicable).
4. Remove both in/out and return header access panels by removing all sheet metal screws.

5. Remove all plumbing fittings to the header. This will include both inlet and outlet water pipe unions and the pressure relief valve and drain piping.
6. Remove limits, control bulbs and/or thermocouples.
7. Remove the eight flange nuts and the in/out header from the left-hand side.
8. Remove the eight flange nuts and the return header from the right-hand side.
9. Reverse the headers to the new location.
10. Install NEW red beveled O-rings flush against both tube sheets with the bevel facing outward.
11. Push the header firmly against the O-rings. Install and tighten the flange nuts onto the stud bolts until finger tight.
12. Slowly tighten the flange nuts, starting from the center nut (number 1) in Fig. 9 and working sequentially around the header as indicated. Torque all nuts to 25 ft/lb. **DO NOT OVER-TIGHTEN.**
13. Re-route the capillary(s), wiring etc. to the new location, adding thermal paste and shim to the capillary well.

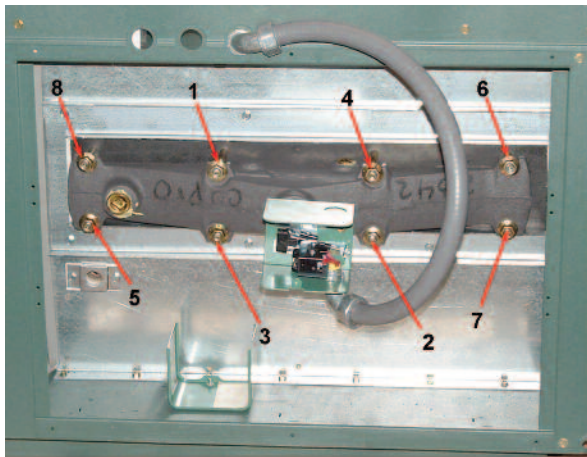

Fig. 9: Torque Sequence

Relief Valve Piping

WARNING: Pressure relief valve discharge piping must be piped near the floor and close to a drain to eliminate the potential of severe burns. Do not pipe to any area where freezing could occur. Refer to local codes.

Hydrostatic Test

Unlike many types of heaters, this heater does not require hydrostatic testing prior to being placed in operation. The heat exchanger has already been factory-tested and is rated for 160 psi operating pressure. However, Raypak does recommend hydrostatic testing of the piping connections to the heater and the rest of the system prior to operation. This is particularly true for hydronic systems using expensive glycol-based anti-freeze. Raypak recommends conducting the hydrostatic test before connecting gas piping or electrical supply.

Leaks must be repaired at once to prevent damage to the heater. NEVER use petroleum-based stop-leak compounds.

To perform hydrostatic test:

1. Connect fill water supply. With bleed valve open, fill heater with water. When water flows from bleed valve, shut off water. Close bleed valve. Carefully fill the rest of the system, making sure to eliminate any entrapped air by using high-point vents. Close feed valve. Test at standard operating pressure for at least 24 hours.
2. Make sure constant gauge pressure has been maintained throughout test.
3. Check for leaks. Repair if found.

Cold Water Operation

CAUTION: Damaging internal condensation may occur if the heater inlet water temperature does not exceed 105°F (41°C) within 7 minutes of start-up.

NOTE: See Raypak Catalog No. 1000.57 for information on Cold Water Protection.

A heater operated with an inlet temperature of less than 105°F (41°C) must have a manual bypass or an approved low-temperature operation system to prevent problems with condensation. A manual bypass, shown in Fig. 15, must be piped into the system at the time of installation. This piping is like a primary/secondary boiler installation with a bypass acting as the secondary boiler piping. Raypak strongly recommends that thermometer(s) be placed into the heater piping next to the in/out header to facilitate temperature adjustment. Inlet water temperatures below 105°F (41°C) can excessively cool the products of combustion, resulting in condensation on the heat exchanger and in the flue.

Failure to exceed 105°F (41°C) within 7 minutes may result in the premature failure of the hot surface igniter, remote flame sensor, burners and heat exchanger. It can cause operational problems, bad combustion, sooting, flue gas spillage and reduced service life of the vent system. The bypass allows part of the heater discharge water to be mixed with the cooler heater return water to increase the heater inlet temperature above 105°F (41°C). This precautionary measure should prevent the products of combustion from condensing in most installations. **Warranty claims will be denied when condensation occurs.**

Cold water operation issues are applicable to both cold water start and cold water run applications. Cold water operation for 7 minutes or less on start-up is acceptable. Where cold water starts will last longer than 7 minutes or where cold water operation is continuous, provisions must be made to mix higher temperature outlet water with the colder inlet water and thereby raise the inlet temperature to at least 105°F (41°C) within the 7-minute time limit.

Cold Water Starts

Frequent (more than once a week) cold water starts, wherein the inlet water temperature remains below 105°F (41°C) for more than 7 minutes, must have cold water start protection. Known protection methods consist of mixing heated outlet water with the inlet water with a bypass to raise the inlet to 105°F (41°C) or higher. Once the system is heated up and has return water temperatures of 105°F (41°C) or higher, the mixing of outlet water with inlet water is no longer needed and the bypass can be shut off. If the bypass is not shut off as the system heats up, the outlet temperature may continue to climb and actuate the high limit, thereby shutting down the heater. Thus an automatic valve system, such as a three-way proportional valve or a modulating two-way valve to control the bypass, should be utilized.

NOTE: Individual and multi-boiler Cold Water Start systems require the use of a 20°F ΔT boiler pump.

Cold Water Run

Cold water run differs from cold water start in that the system water entering the heater remains below 105°F (41°C) continuously. Typically, this is the case in swimming pool heating and water source heat pump applications as well as some others. If the system water is kept in a narrow temperature range, a permanent manual bypass can be employed and manually adjusted to achieve an inlet temperature of 105°F

(41°C) or higher. An injector pump arrangement may also be utilized to keep the heater loop at or above 105°F (41°C). An injector pump approach has the added value of being able to adjust to changes in the system water coming back to the heater take-off.

NOTE: To ensure proper operation, use 20°F ΔT boiler flow rates when designing the heating system loop pump.

Temperature & Pressure Gauge

The temperature and pressure gauge is factory-mounted in the in/out header.

Hydronic Heating

System Design

Hot water heating systems all have unique levels of operating diversity. Raypak equipment design utilizes as little water mass as possible to ensure maximum operating efficiency. Primary / Secondary piping arrangement is the method recommended and the only method supported by Raypak for installation of Raypak heating equipment. Proper system design should always include system flow in excess of the connected boiler flow for proper operation (Boiler Flow + 15% = Min. System Flow). When appropriate, a Buffer/De-coupler Tank can be used where system flow may be reduced below the connected boiler flow. Failure to design for adequate system flow (i.e. bypasses, 3-way control valves, flow limiting balance devices, buffer tanks, etc.) will result in boiler short cycling and poor system performance. Always contact your local Raypak representative for system design assistance to avoid these issues.

Pump Selection

In order to ensure proper performance of your heater system, you must install a correctly sized pump. Raypak recommends using a 20°F ΔT as design ΔT . (ΔT is the temperature difference between the inlet and outlet water when the heater is firing at full rate). If a ΔT of larger than 20°F is necessary, see Table G and Table H for flow rate requirements.

Model No.	20°FΔT		30°FΔT		40°FΔT		Min. Flow			Max Flow		
	gpm	ΔP (ft)	gpm	ΔP (ft)	gpm	ΔP (ft)	gpm	ΔP (ft)	ΔT	gpm	ΔP (ft)	ΔT
992B	83	5.2	55	2.3	42	1.3	42	1.3	40	132	13.1	13
1262B	106	9.6	71	4.3	53	2.4	53	2.4	40	132	14.8	16
1532B	129	15.7	86	7.1	64	4.0	64	4.0	40	132	16.5	19
1802B	N/A	N/A	101	10.7	76	6.0	76	6.0	40	132	18.3	23
2002B	N/A	N/A	112	13.8	84	7.9	84	7.9	40	132	19.0	25
2072B	N/A	N/A	116	14.8	87	8.5	87	8.5	40	132	19.0	26
2342B	N/A	N/A	132	21.1	98	12.1	98	12.1	40	132	21.4	30

Notes: 1. Basis for minimum flow is 40°F ΔT. Basis for maximum flow is 132 GPM.
2. Rear-mounted pumps may provide higher flow rates on smaller models than the system requirements

Table G: Heater Rates of Flow and Pressure Drops

Feedwater Regulator

Raypak recommends that a feedwater regulator be installed and set at 12 psi minimum pressure at the highest point of the system. Install a check valve or back flow device upstream of the regulator, with a manual shut-off valve as required by local codes.

Piping

All high points should be vented. Purge valves and a bypass valve should be installed. A heater installed above radiation level must be provided with a low water cut-off device (sales order option F-10). The heater, when used in connection with a refrigeration system, must be installed so that the chilled medium is piped in parallel with the heater with appropriate valves to prevent the chilled medium from entering the heater.

The piping system of a hot water heater connected to heating coils located in air handling units where they may be exposed to circulating refrigerated air, must be equipped with flow control valves or other automatic means to prevent gravity circulation of the heater water during the cooling cycle. It is highly recommended that the piping be insulated.

Air-Separation/Expansion Tank

All heaters should be equipped with a properly sized expansion tank and air separator fitting as shown in Fig. 10.

Three-Way Valves

Valves designed to blend water temperatures or reduce water circulation through the heater should not be used. Raypak heaters are high-recovery, low-mass heaters which are not subject to thermal shock.

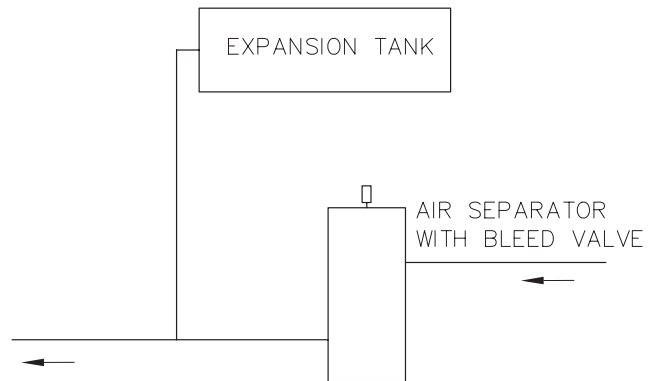

Fig. 10: Air-Separation/Expansion Tank

Raypak offers a full line of electronic sequencers that produce direct reset of heater water temperature. (Refer to the Controls section of the Raypak Catalog.)

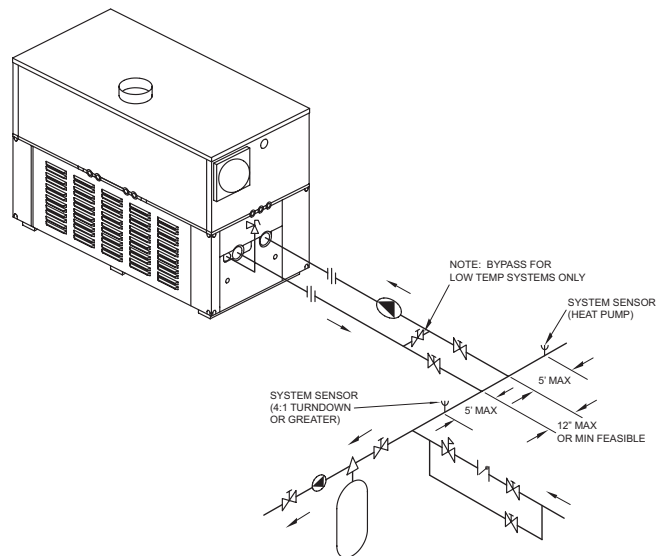

Fig. 11: Single Heater - Space Heating Application with Primary/Secondary Piping

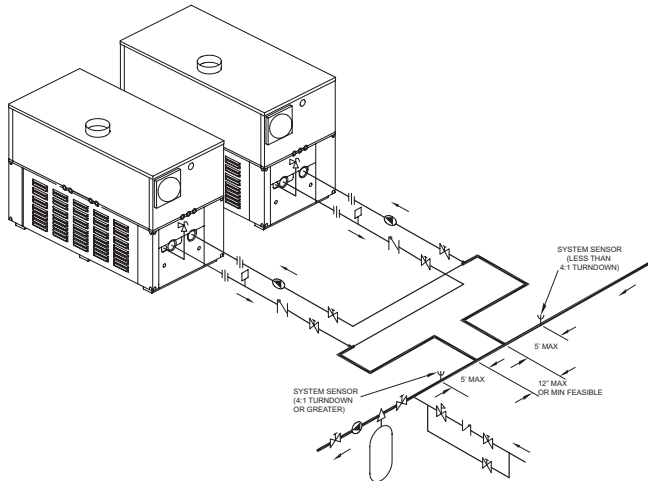

Fig. 12: Dual Heaters (Reverse/Return) with Primary/Secondary Piping

Domestic Hot Water

When designing the water piping system for domestic hot water applications, water hardness should be considered. Table H indicates the suggested flow rates for soft, medium and hard water. Water hardness is expressed in grains per gallon. Water softened as low as 0 to 3 grains per gallon is known to be aggressive and corrosive.

Potable Water and Space Heating

CAUTION: When this heater is used for both potable water and space heating, observe the following to ensure proper operation.

1. All piping materials and components connected to the water heater for the space heating application shall be suitable for use with potable water.
2. Toxic chemicals, such as used for boiler treatment, shall not be introduced into the potable water used for space heating.
3. If the heater will be used to supply potable water, it shall not be connected to any heating system or components previously used with a non-potable water heating appliance.
4. When the system requires water for space heating at temperatures higher than 140°F, a means such as a mixing valve shall be installed to temper the water in order to reduce scald hazard potential.

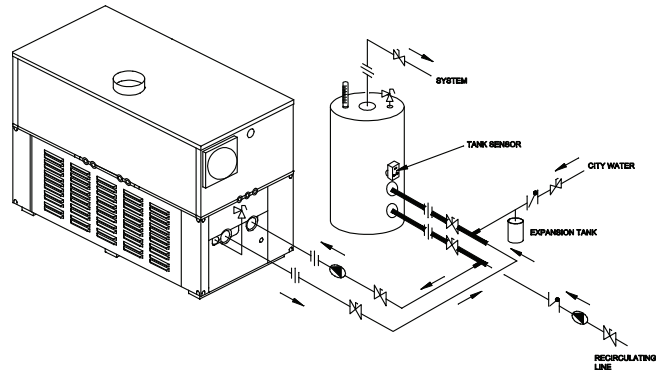

Fig. 13: Single Domestic Hot Water Heater and Storage Tank

Pool Heating

CAUTION: Power to the heater should be interlocked with the main system pump to make sure the heater does not fire without the main system pump in operation. Improper flow control can damage the heater. Uncontrolled flow (too high) or restricted flow (too low) can seriously damage the heater. Follow these instructions to make sure your heater is properly installed.

The Hi Delta pool heater is equipped with an external pump and bypass arrangement as standard equipment. This arrangement blends outlet water with the inlet water to increase the inlet water temperature, thereby reducing the likelihood of condensation forming on the heat exchanger. The pump also serves to circulate water through the heater from the main system piping.

To complete the installation of the pool heater, the pool thermostat needs to be installed in the main return water line, upstream of the heater. This will ensure that

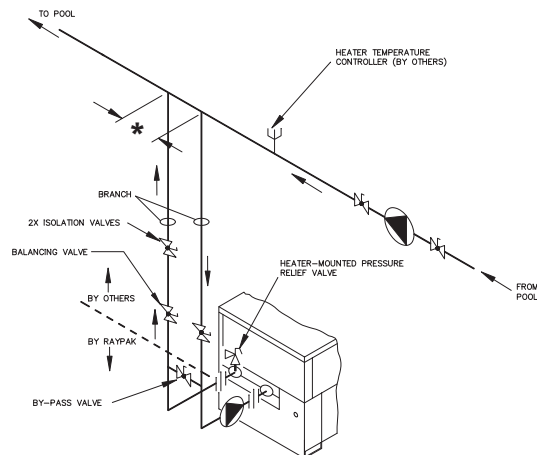

*Maximum 4 times the pipe diameter or 12", whichever is less.

Fig. 14: Single Pool Heater Application

Model No.	Soft* (3-4 grains per gallon)					Medium (5-15 grains per gallon)					Hard* (16+** grains per gallon)				
	ΔT	GPM	ΔP	MTS	SHL	ΔT	GPM	ΔP	MTS	SHL	ΔT	GPM	ΔP	MTS	SHL
992B	28	60	2.7	2½	5.2	17	98	7.3	2½	13.3	13	132	13.1	2½	23.6
1262B	30	72	4.4	2½	7.9	19	115	11.3	2½	19.4	16	132	14.8	2½	25.3
1532B	30	86	7.1	2½	11.9	22	120	13.7	2½	22.5	20	132	16.5	2½	27.0
1802B	30	102	10.9	2½	17.4	26	120	15.1	2½	23.9	23	132	18.3	2½	28.7
2002B	30	112	13.9	2½	21.6	26	132	19.0	2½	29.5	26	132	19.0	2½	29.5
2072B	31	117	15.1	2½	23.4	27	132	19.0	2½	29.5	27	132	19.0	2½	29.5
2342B	33	120	17.8	2½	26.5	30	132	21.4	2½	31.8	30	132	21.4	2½	31.8

ΔT = Temperature rise, °F

ΔP = Pressure drop through heat exchanger, ft

SHL = System head loss, ft. Includes 50 eq ft of tubing each way (total 100 eq ft).

GPM = Gallons per minute, flow rate

MTS = Minimum tubing size

*Must utilize optional cupro-nickel tubes.

**If over 25 grains per gallon, a water softener/treatment system must be utilized.

Caution: For scale free operation with "Hard Water" (16-25 grains per gallon of total hardness), the operating control must NOT be set higher than 130 °F. For higher than 130 °F operation, a water softener/treatment system must be utilized.

Caution: Water softened below 3 grains per gallon is known to be aggressive and corrosive.

Table H: Domestic Water Heater Flow Rate Requirements

the heater will be energized at the right time. If the main water line is too far away from the heater and the capillary bulb will not reach it, locate the pool thermostat adjacent to the main line and run wires back to the heater.

Adjustment of the manual bypass valve is critical to proper operation of the heater. The manual bypass valve should be adjusted to achieve a minimum inlet water temperature of 105°F and an outlet water temperature below 140°F. When starting with a cold pool, make initial adjustments. Make final adjustments when pool water approaches desired temperature.

The use of a bypass is required for proper operation in a pool heating application. Use the following instructions to set the manual bypass:

1. Set Valve A (the bypass) to ½ open position, and Valve B to fully open position.
2. Turn on pump.
3. Turn on heater and wait until heater goes to full fire.
4. Adjust Valve A until the inlet water temperature is 105°F. NOTE: Opening the valve will increase the temperature and closing the valve will decrease the temperature.

5. If this process does not raise the inlet water temperature to 105°F and Valve A is fully open, then slowly throttle Valve B closed to increase the inlet water temperature to 105°F.

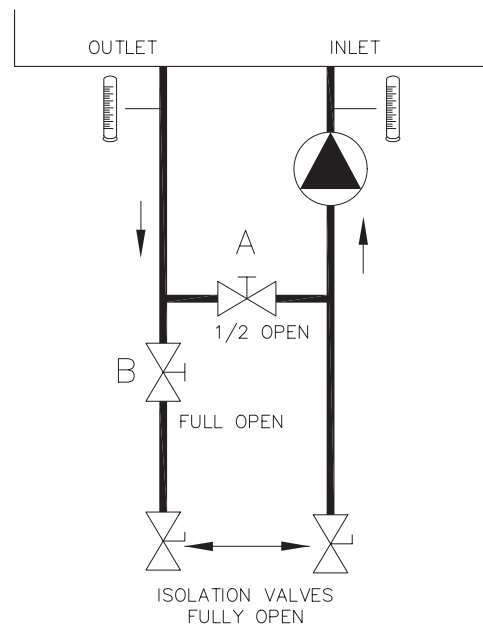

Fig. 15: "H" Bypass Setting

Automatic Chlorinators and Chemical Feeders

CAUTION: Combustion air must not be contaminated by corrosive chemical fumes which can damage the heater and void the warranty.

All chemicals must be introduced and completely diluted into the pool or spa water before being circulated through the heater. Do not place chlorine tablets or bromine sticks in the skimmer. High chemical concentrations will result when the pump is not running (e.g. overnight).

Chlorinators must feed downstream of the heater and have an anti-siphoning device to prevent chemical back-up into the heater when the pump is shut off.

NOTE: High chemical concentrates from feeders and chlorinators that are out of adjustment will cause very rapid corrosion of the heat exchanger in the heater. Such damage is not covered under the warranty.

Pool Heating - P Models

All Raypak pool heaters are certified to ANSI Z21.56, which is the nationally recognized standard for swimming pools. Some heaters being sold in the marketplace for heating commercial swimming pools are often certified as hot water boilers or water heaters. Regardless of which standard they are certified to, they are generally trimmed out either by the manufacturer or the installer with controls that are suitable for maintaining normal swimming pool temperatures and water conditions.

Some Raypak P models are configured to accommodate locating the outlet temperature controller in the pool system piping that supplies the heated water to the pool. This arrangement facilitates controlling or limiting the temperature of the water supplied to the pool. In such systems, the heater must be plumbed in a primary/secondary arrangement, wherein only a small portion of the water flowing in the piping system is pulled off, heated, and then returned to the system. In such systems, the water coming out of the heater is mixed with the filtered water in the main pipe and thus tempered before returning to the pool. This arrangement permits operation of the heater at a temperature range that has been optimized both to avoid damaging condensation on the heat exchanger and to mitigate the formation of scale in the heat exchanger tubes.

When a boiler or water heater is used in a pool heat-

ing application, ensure that all the following installation requirements are met:

Bypass information
Piping information
Outlet thermostat/limit
Heater limit
Pool thermostat

To complete the installation of the heater, the poolstat must be installed in the return water line from the pool, upstream of the heater. A factory-supplied operating control is configured to operate as the pool thermostat. A separate auto limit is shipped loose to be installed in the system piping downstream of the heater as the outlet thermostat. See Fig. 16 for details.

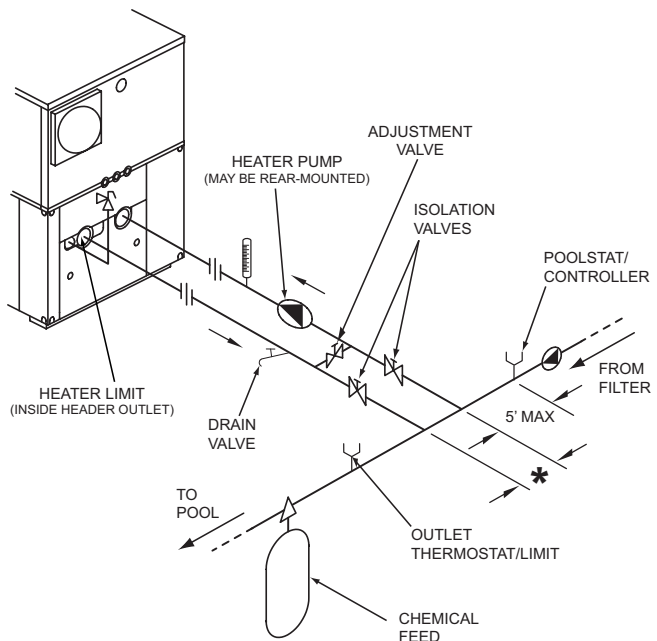

*Maximum 4 times the pipe diameter or 12", whichever is less.

Fig. 16: Component Locations - WHP Models

NOTE: The recommended setting for the outlet thermostat is 110°F.

Winterizing Your Heater

Heaters installed outdoors in freezing climate areas should be shut down for the winter. To shut down heater, turn off manual main gas valve and main gas shut-off. Close isolation valves and remove water piping from the in/out header on the heater. Drain the heater and any piping of all water that may experience below-freezing temperatures.

Pool/Spa Water Chemistry

NOTE: Chemical imbalance can cause severe damage to your heater and associated equipment.

Water Hardness

Water hardness is mainly due to the presence of calcium and magnesium salts dissolved in the water. The concentration of these salts is expressed in mg/l, ppm or grains per gallon, as a measure of relative hardness of water. Grains per gallon is the common reference measurement used in the U.S. water heater industry. Hardness expressed as mg/L or ppm may be divided by 17.1 to convert to grains per gallon. Water may be classified as very soft, slightly hard, moderately hard or hard based on its hardness number. The salts in water will precipitate out when the water is heated and will cause accelerated lime and scale accumulation on a heat transfer surface.

Raypak water heaters can operate lime/scale-free using potable water with a hardness not exceeding 25 grains per gallon. Proper operation is achieved by setting the temperature rise/water flow per the guidelines in the installation instructions. If the hardness of the water exceeds the maximum level of 25 grains per gallon special measures must be taken to adjust flow and temperature rise. Water should be softened to a hardness level no lower than 5 grains per gallon. Water softened below 3 grains per gallon may be under-sat-

urated with respect to calcium carbonate resulting in water that is aggressive and corrosive.

pH of Water

pH is a measure of relative acidity, neutrality or alkalinity. Dissolved minerals and gases affect water's pH. The pH scale ranges from 0 to 14. Water with a pH of 7.0 is considered neutral. Water with a pH lower than 7 is considered acidic. Water with a pH higher than 7 is considered alkaline. A neutral pH (around 7) is desirable for most potable water applications. Corrosion damage and water heater failures resulting from water pH levels of lower than 6 or higher than 8 are non-warrantable. The ideal pH range for water used in a storage tank or a copper water heater system is 7.2 to 7.8.

Total Dissolved Solids

Total dissolved solids (TDS) is the measure of all minerals and solids that are dissolved in the water. The concentration of total dissolved solids is usually expressed in parts per million (ppm) as measured in a water sample. Water with a high TDS concentration will greatly accelerate lime and scale formation in the hot water system. Most high TDS concentrations will precipitate out of the water when heated. This can generate a scale accumulation on the heat transfer surface that will greatly reduce the service life of a water heater. This scale accumulation can also impede adequate flow of water and may totally block

Recommended Level(s)	Fiberglass Pools	Fiberglass Spas	Other Pool and Spa Types
Water Temperature	68-88°F (20-31°C)	89-104°F (31-40°C)	68-104°F (20-40°C)
pH	7.3-7.4	7.3-7.4	7.6-7.8
Total Alkalinity (ppm)	120-150	120-150	80-120
Calcium Hardness (ppm)	200-300	150-200	200-400
Salt (ppm)	3000 Maximum	3000 Maximum	3000 Maximum
Free Chlorine (ppm)*	2-3	2-3	2-3
Total Dissolved Solids (ppm)	1500 Maximum**	1500 Maximum**	1500 Maximum**

*Free Chlorine **MUST NOT EXCEED 5 ppm!**

**In salt water chlorinated pools, the total TDS can be as high as 4500ppm

NOTE: The allowable concentrations of salt and of the Total Dissolved Solids are lower for the Hi Delta than for a typical residential pool heater, due to the higher water temperatures at which a Hi Delta operates.

Table I: Water Chemistry

the water passages in the tubes of the heat exchanger. A heat exchanger that is damaged or blocked by lime/scale accumulation must be replaced. Failure of a water heater due to lime scale build up on the heating surface is non-warrantable. The manufacturer of the water heater has no control of the water quality, especially the TDS levels in your system. Total dissolved solids in excess of 1,500 ppm will accelerate lime and scale formation in the heat exchanger. Heat exchanger failure due to total dissolved solids in excess of 1,500 ppm is a non-warrantable condition. Raypak offers basic temperature guidelines for operation of a potable water heater on normal to moderate levels of hardness and solids but levels of hardness and total dissolved solids beyond normal limits for operation will require special setup and operation.

NOTE: Failure of a heat exchanger due to lime scale build-up on the heating surface, low pH or other chemical imbalance is non-warrantable.

Gas Supply

DANGER: Make sure the gas on which the heater will operate is the same type as specified on the heater's rating plate.

Gas piping must have a sediment trap ahead of the heater gas controls, and a manual shut-off valve located outside the heater jacket. It is recommended that a union be installed in the gas supply piping adjacent to the heater for servicing. A pounds-to-inches regulator must be installed to reduce the gas supply pressure to a maximum of 10.5 in. WC for natural gas and 13.0 in. WC for propane gas. The regulator should be placed a minimum distance of 10 times the pipe diameter up-stream of the heater gas controls. Refer to Table J for maximum pipe lengths.

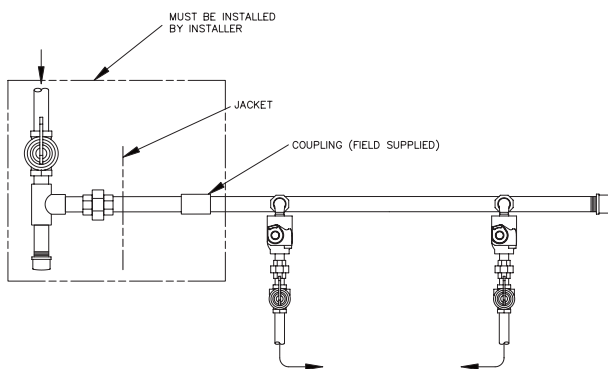

Fig. 17: Gas Supply Connection

Gas Supply Connection

CAUTION: The heater must be disconnected from the gas supply during any pressure testing of the gas supply system at test pressures in excess of 1/2 psi (3.45 kPa).

The heater must be isolated from the gas supply piping system by closing the manual shut-off valve during any pressure testing of the gas supply piping system at test pressures equal to or less than 1/2 psi (3.45 kPa). Relieve test pressure in the gas supply line prior to reconnecting the heater and its manual shut-off valve to the gas supply line. **FAILURE TO FOLLOW THIS PROCEDURE MAY DAMAGE THE GAS VALVES.** Over pressurized gas valves are not covered by warranty. The heater and its gas connections shall be leak-tested before placing the appliance in operation. Use soapy water for leak test. **DO NOT** use an open flame.

CAUTION: Do not use Teflon tape on gas line pipe thread. A pipe compound rated for use with natural and propane gases is recommended. Apply sparingly only on male pipe ends, leaving the two end threads bare.

CAUTION: Support gas supply piping with hangers, not by the heater or its accessories. Make sure the gas piping is protected from physical damage and freezing, where required.

Reversing Gas Supply Connection

Reversing the standard fuel connection from the left-hand to the right-hand side is a simple field operation.

1. Disconnect all electrical power from the heater (if applicable).
2. Disconnect the main gas pipe from the heater (if applicable).
3. Remove the left and right front panels from the heater.
4. Locate the main gas line that traverses across the heater above the manifold risers.
5. Remove the pipe cap from the right-hand end of the main gas line.
6. Reinstall the pipe cap on the left-hand end of the main gas line.

Model No.	2"		2-1/2"		3"		4"	
	N	P	N	P	N	P	N	P
992B	120	300	300	--	--	--	--	--
1262B	75	180	170	325	560	--	--	--
1532B	50	120	125	250	400	--	--	--
1802B	40	100	100	225	340	--	--	--
2002B	30	80	75	175	260	--	--	--
2072B	30	80	75	175	260	--	--	--
2342B	20	55	55	135	160	400	600	--

Natural gas – 1,000 BTU per ft³, .60 specific gravity at 0.5 in. WC pressure drop
 Propane gas – 2,500 BTU per ft³, 1.53 specific gravity at 0.6 in. WC pressure drop

Table J: Maximum Equivalent Pipe Length

7. Remove plastic cap from the right-hand side panel and reinstall into the standard main gas opening located on the left-hand side of the heater.
8. Remove the rubber grommet from the left-hand-side panel and reinstall into the standard main gas opening, located on the right-hand side of the heater.
9. Install a coupling, nipple, union and sediment trap onto the right-hand end of the main gas line and then install the gas line, making sure that a manual shut-off valve has been installed within 10 ft of the heater.
10. Replace the left and right front panels on the heater.

The gas valve pressure regulator(s) on the heater are nominally preset at 3.5 in. WC for natural gas, and 10.5 in. WC for propane gas. The pressure at the gas valve outlet tap, measured with a manometer, while in operation should be 3.5 ± 0.1 in. WC for natural gas and 10.5 in. ± 0.1 in. WC for propane gas. If an adjustment is needed, remove the adjustment screw cover and turn the adjustment screw clockwise to increase pressure or counter-clockwise to lower pressure.

Gas Supply Pressure

A minimum of 5.0 in. WC upstream gas pressure under full load and a maximum gas supply pressure set point of 10.5 in. WC under load and no-load conditions are required for natural gas. A minimum of 11.0 in. WC upstream gas pressure under full load and a maximum gas supply pressure set point of 13.0 in. WC are required for propane gas. The gas pressure regulator(s) supplied on the heater is for low-pressure service. If upstream pressure exceeds 14.0 in. WC (1/2 psi) **at any time**, an intermediate gas pressure regulator, of the lockup type, must be installed.

When connecting additional gas utilization equipment to the gas piping system, the existing piping must be checked to determine if it has adequate capacity for the combined load.

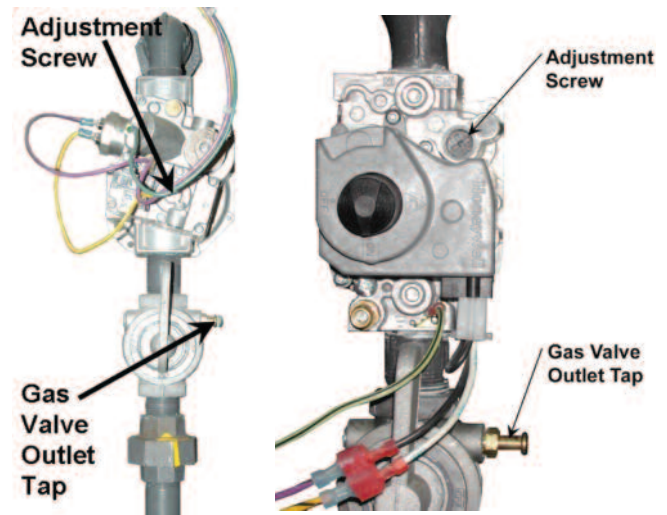

Fig. 18: Gas Valves

Electrical Power Connections

Installations must follow these codes:

- National Electrical Code and any other national, state, provincial or local codes or regulations having jurisdiction.
- Safety wiring must be NEC Class 1.
- Heater must be electrically grounded as required by the NEC.
- In Canada, CSA C22. 1 C.E.C. Part 1.

The heater is wired for 120 VAC, <12 amps in its basic configuration. Additional options may increase the amp draw of the unit. The voltage is indicated on the tie-in leads. Consult the wiring diagram shipped with the heater in the instruction packet. The remote tank control stat, thermostat, or electronic heater control (as applicable) may be connected to the stage selector terminal (See wiring diagram). 24 VAC is supplied to this connection through the heater transformer. **DO NOT attach any voltage to the stage selector terminals.** Before starting the heater check to ensure proper voltage to the heater and pump.

Install a separate disconnect means for each load. Use appropriately sized wire as defined by NEC, CSA and/or local code. All primary wiring should be at least 125% of minimum rating.

If any of the original wire as supplied with the heater must be replaced, it must be replaced with 105°C wire or its equivalent.

Field-Connected Controllers

It is strongly recommended that all individually-powered control modules and the heater should be supplied from the same power source.

NOTE: Field-supplied isolation relays should be installed when field-connected controllers are mounted more than 50 equivalent feet (18 Ga) from heater.

Check the Power Source

WARNING: Using a multi-meter, check the following voltages at the terminal block inside the unit. Make sure proper polarity is followed and house ground is proven. (See Fig. 19.)

NOTE: Minimum 18 AWG, 105°C, stranded wire must be used for all low voltage (less than 30 volts) external connections to the unit. Solid conductors should not be used because they can cause excessive tension on contact points. Install conduit as appropriate. All high voltage wires must be the same size (105°C, stranded wire) as the ones on the unit or larger.

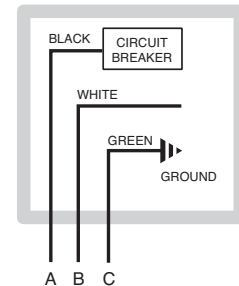

Fig. 19: Wiring Connections

Check the power source:

AC = 108 VAC Minimum, 132 VAC MAX
AB = 108 VAC Minimum, 132 VAC MAX
BC = <1 VAC Maximum

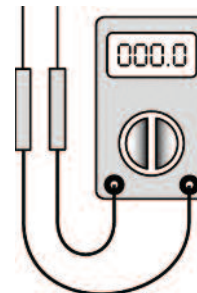

Fig. 20: Multi-meter

If the heater does not have a factory-wired stage controller, it is factory-wired in an on-off configuration with other stage terminals jumpered.

To field-connect a stage controller, remove factory-installed jumpers and wire stage controller as shown in Fig. 22-25.

Making the Electrical Connections

Refer to Fig. 19-27.

1. Verify that circuit breaker is properly sized by referring to heater rating plate. A dedicated circuit breaker should be provided.
2. Turn off all power to the heater. Verify that power has been turned off by testing with a multi-meter

prior to working with any electrical connections or components.

3. Observe proper wire colors while making electrical connections. Many electronic controls are polarity sensitive. Components damaged by improper electrical installation are not covered by warranty.
4. Provide overload protection and a disconnect means for equipment serviceability as required by local and state code.
5. Install heater controls, thermostats, or building management systems in accordance with the applicable manufacturers' instructions.
6. Conduit shall not be used as the earth ground.

NOTE: A grounding electrode conductor shall be used to connect the equipment grounding conductors, the equipment enclosures, and the grounded service conductor to the grounding electrode.

Field Wiring Connection

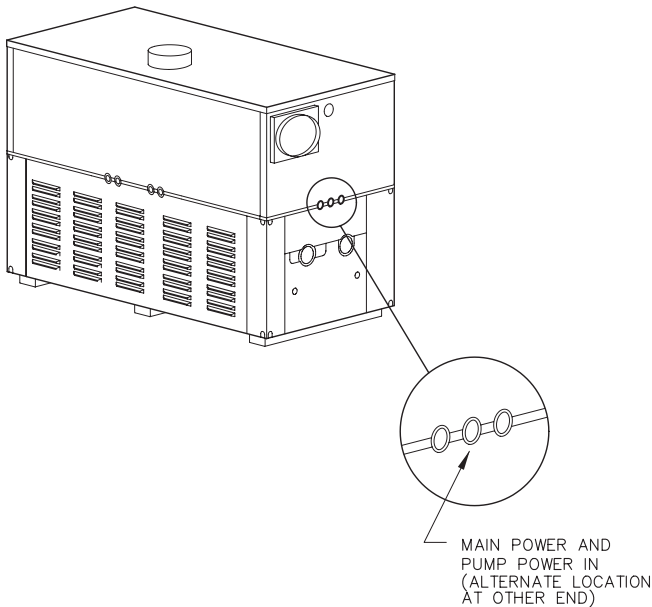

Fig. 21: Wiring Location

CAUTION: Label all wires prior to disconnection when servicing controls. Wiring errors can cause improper and dangerous operation. Verify proper operation after servicing.

DANGER: SHOCK HAZARD

Make sure electrical power to the heater is disconnected to avoid potential serious injury or damage to components.

ON/OFF

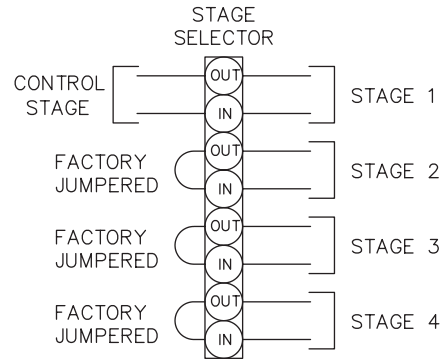

MODELS 992B-2342B

Fig. 22: On-Off Wiring Connections

2-STAGE

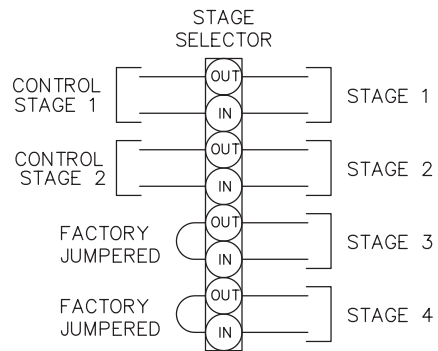

MODEL 992B

2-STAGE

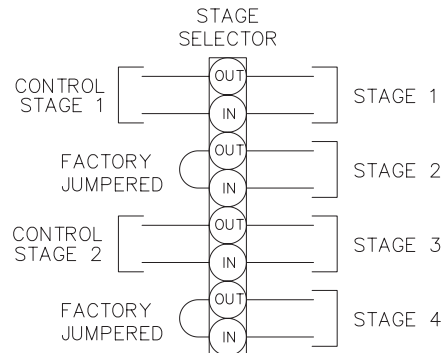

MODELS 1262B-2342B

Fig. 23: 2-Stage Wiring Connections

3-STAGE

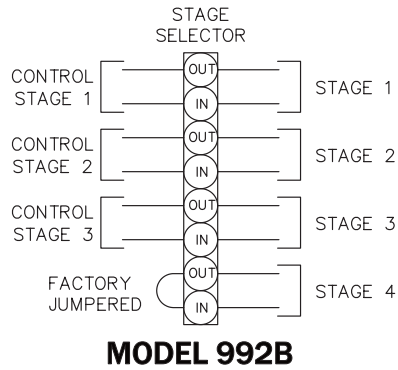

MODEL 992B

3-STAGE

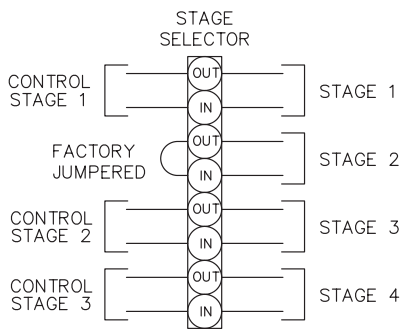

MODELS 1262B-2342B

Fig. 24: 3-Stage Wiring Connections

4-STAGE

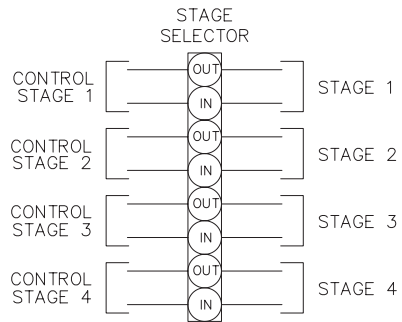

MODELS 1262B-2342B

Fig. 25: 4-Stage Wiring Connection

Installer action is required to electrically enable your heater to operate after making the power connections. You must make a closed contact connection on Stage 1 connector of the Central Point Wiring (CPW) board for temperature control connections. This will be done based on the controller option selected with your heater order.

1. For Pool and Closed-Loop Water-Source Heat Pump applications with a fixed bypass, your heater should be configured to operate in an on-off

firing mode. This means that you will connect a single-pole control to stage one of the CPW board. Then jumper the remaining firing stages. For example, if your heater is a Model 1532B, you will jumper stages two, three and four. Then your heater will either be on at full fire, or it will be off.

2. For 2-stage controller connections, connect each stage of the control to the corresponding stage of the CPW board in the heater, i.e., stage 1 of the heater to stage 1 of the control; stage 2 of the heater to stage 2 of the control, as shown in Fig. 23 and Fig. 26. Set the operating control to the set-point at which you want the heater to maintain. Ensure that the sensing bulb of the control is at the point in the system that will best maintain the temperature you want. For example, when you are heating a tank of water, you want the operating control sensor bulb in the tank.
3. For single-stage controller connections, attach the stage 1 connections on heater 1 to the tankstat per Fig. 27.

Heater must be electrically grounded in accordance with the NEC, and CSA C22.1 C.E.C. Part 1 in Canada.

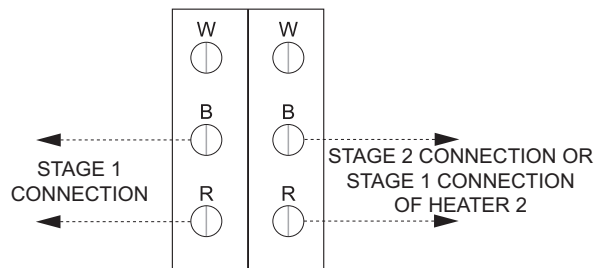

ATTACH STAGE 1 CONNECTIONS ON HEATER TO STAGE 1 CONNECTION ON TANKSTAT.
ATTACH STAGE 2 CONNECTIONS OR STAGE 1 CONNECTION OF HEATER 2 TO STAGE 2 CONNECTION ON TANKSTAT AS SHOWN IN THE DIAGRAM.

Fig. 26: 2-Stage Mechanical Tankstat

Consult the wiring diagram shipped with the heater in the instruction packet or at the end of this section. The stage-selector terminals are for the remote tank control through the heater's 24 VAC transformer. **DO NOT attach any voltage to the stage-selector terminals.** Before starting the heater, check to ensure proper voltage to the heater and pump.

NOTE: If any of the original wire supplied with the heater must be replaced, it must be replaced with similar sized 105°C wire or its equivalent.

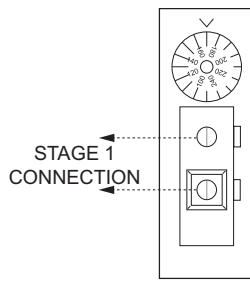

ATTACH STAGE 1 CONNECTIONS ON HEATER TO THE SINGLE STAGE TANKSTAT AS SHOWN IN THE DIAGRAM ABOVE.

Fig. 27: Single-Stage Mechanical Tankstat

Category II – A heater which operates with a non-positive vent static pressure and with a vent gas temperature that may cause excessive condensate production in the vent.

Category III – A heater which operates with a positive vent pressure and with a vent gas temperature that avoids excessive condensate production in the vent.

Category IV – A heater which operates with a positive vent pressure and with a vent gas temperature that may cause excessive condensate production in the vent.

See Table L for appliance category requirements.

Venting

NOTE: For 87%-efficiency boilers, see special instructions on page 48.

CAUTION: Proper installation of flue venting is critical for the safe and efficient operation of the heater.

NOTE: For additional information on appliance categorization, see appropriate ANSI Z21 Standard and the NFGC (U.S.), or B149 (Canada), or applicable provisions of local building codes.

CAUTION: When condensate traps are installed, condensate must be routed to an appropriate container for neutralization before disposal, as required by local codes.

General

Flue Exhaust Tee

An optional Flue Exhaust Tee is available to facilitate horizontal venting. Any reference to horizontal venting that exits the back of the heater requires this tee. Refer to Table K for the appropriate kit for your model.

CAUTION: Condensate is acidic and highly corrosive.

WARNING: Contact the manufacturer of the vent material if there is any question about the appliance categorization and suitability of a vent material for application on a Category III or IV vent system. Using improper venting materials can result in personal injury, death or property damage.

Model	Diameter	Order Number
992B	10"	011841
1262B, 1532B	12"	011842
1802B, 2002B, 2072B	14"	011843
2342B	16"	011844

Table K: Flue Exhaust Tee Kits

Support of Vent Stack

The weight of the vent stack or chimney must not rest on the heater vent connection. Support must be provided in compliance with applicable codes. The vent should also be installed to maintain proper clearances from combustible materials.

Use insulated vent pipe spacers where the vent passes through combustible roofs and walls.

NOTE: During winter months check the vent cap and make sure no blockage occurs from build-up of snow or ice.

Appliance Categories

Heaters are divided into four categories based on the pressure produced in the exhaust and the likelihood of condensate production in the vent.

Category I – A heater which operates with a non-positive vent static pressure and with a vent gas temperature that avoids excessive condensate production in the vent.

Vent Terminal Location

1. Condensate can freeze on the vent cap. Frozen condensate on the vent cap can result in a blocked flue condition.
2. Give special attention to the location of the vent termination to avoid possibility of property damage or personal injury.
3. Gases may form a white vapor plume in winter. The plume could obstruct a window view if the termination is installed near windows.
4. Prevailing winds, in combination with below-freezing temperatures, can cause freezing of condensate and water/ice build-up on buildings, plants or roofs.
5. The bottom of the vent terminal and the air intake shall be located at least 12 in. above grade, including normal snow line.
6. Un-insulated single-wall metal vent pipe shall not be used outdoors in cold climates for venting gas-fired equipment.
7. Through-the-wall vents for Category II and IV appliances and non-categorized condensing appliances shall not terminate over public walkways or over an area where condensate or vapor could create a nuisance or hazard or could be detrimental to the operation of regulators, relief valves, or other equipment. Where local experience indicates that condensate is a problem with Category I and III appliances, this provision shall also apply.
8. Locate and guard vent termination to prevent accidental contact by people or pets.

9. DO NOT terminate vent in window well, stairwell, alcove, courtyard or other recessed area.
10. DO NOT terminate above any door, window, or gravity air intake. Condensate can freeze, causing ice formations.
11. Locate or guard vent to prevent condensate from damaging exterior finishes. Use a rust-resistant sheet metal backing plate against brick or masonry surfaces.
12. DO NOT extend exposed vent pipe outside of building. Condensate could freeze and block vent pipe.

U.S. Installations

Refer to the latest edition of the National Fuel Gas Code.

Vent termination requirements are as follows:

1. Vent must terminate at least 4 ft below, 4 ft horizontally from or 1 ft above any door, window or gravity air inlet to the building.
2. The vent must not be less than 7 ft above grade when located adjacent to public walkways.
3. Terminate vent at least 3 ft above any forced air inlet located within 10 ft.
4. Vent must terminate at least 4 ft horizontally, and in no case above or below unless 4 ft horizontal distance is maintained, from electric meters, gas meters, regulators, and relief equipment.
5. Terminate vent at least 6 ft away from adjacent walls.

Combustion Air Supply	Exhaust Configuration	Heater Venting Category	Certified Materials	Combustion Air Inlet Material
From Inside Building (Non-Direct Venting)	Vertical Natural Draft Venting	I	"B" Vent	
	Horizontal Through-the-Wall Venting	III	Stainless Steel (Gas Tight)	
From Outside Building (Direct Venting)	Vertical Natural Draft Venting	I	"B" Vent	Galvanized Steel PVC ABS CPVC
	Horizontal Through-the-Wall Venting	III	Stainless Steel (Gas Tight)	

Table L: Venting Category Requirements

6. DO NOT terminate vent closer than 5 ft below roof overhang.
7. The vent terminal requires a 12 in. vent terminal clearance from the wall.
8. Terminate vent at least 1 ft above grade, including normal snow line.
9. Multiple direct vent installations require a 4 ft clearance between the ends of vent caps located on the same horizontal plane.

Canadian Installations

Refer to latest edition of B149 Installation code.

A vent shall not terminate:

1. Directly above a paved sidewalk or driveway which is located between two single-family dwellings and serves both dwellings.
2. Less than 7 ft (2.13 m) above a paved sidewalk or paved driveway located on public property.
3. Within 6 ft (1.8 m) of a mechanical air supply inlet to any building.
4. Above a meter/regulator assembly within 3 ft (915 mm) horizontally of the vertical centre-line of the regulator.
5. Within 6 ft (1.8 m) of any gas service regulator vent outlet.
6. Less than 1 ft (305 mm) above grade level.
7. Within the 3 ft (915 mm) of a window or door which can be opened in any building, any non-mechanical air supply inlet to any building or the combustion air inlet of any other appliance.
8. Underneath a verandah, porch or deck, unless the verandah, porch or deck is fully open on a minimum of two sides beneath the floor, and the distance between the top of the vent termination and the underside of the verandah, porch or deck is greater than 1 ft (305 mm).

Changing the Flue Outlet

The flue connection may be changed from the top to the rear of the heater using the optional flue exhaust tee kit (see Fig. 28). Follow the directions given in the Flue Exhaust Tee kit instruction, Catalog No. 1000.59.

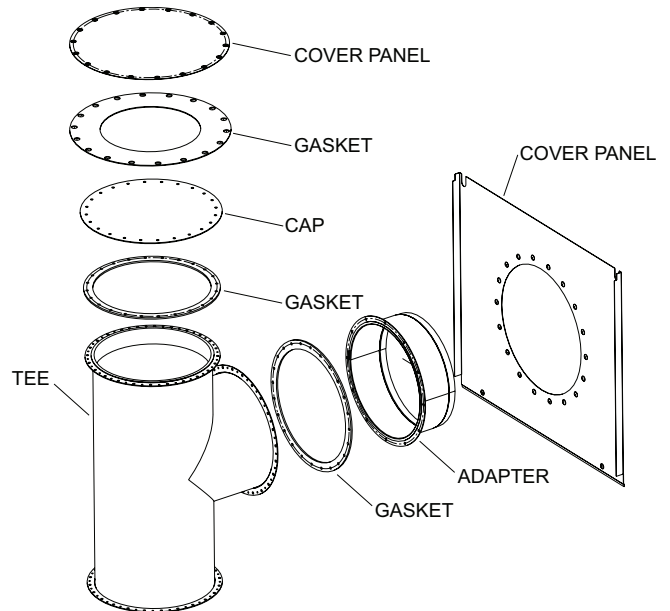

Fig. 28: Flue Exhaust Tee Kit

CAUTION: The silicone vent gaskets must be properly reinstalled to prevent flue gas leakage. Replace any torn or worn vent gaskets.

Venting Installation Tips

Support piping:

- horizontal runs - at least every 5 ft
- vertical runs - use braces
- under or near elbows

WARNING: Examine the venting system at least once a year. Check all joints and vent pipe connections for tightness, corrosion or deterioration.

Venting Configurations

For heaters connected to gas vents or chimneys, vent installations shall be in accordance with the NFGC (U.S.), or B149 (Canada), or applicable provisions of local building codes.

Natural Draft Vertical Venting (Category I)

Installation

Natural draft venting uses the natural buoyancy of the heated flue products to create a thermal driving head that expels the exhaust gases from the flue. The negative draft must be within the range of $-.01$ to $-.08$ in. WC as measured 12 in. above the appliance flue outlet to ensure proper operation. Vent material must be listed by a nationally recognized test agency.

The maximum and minimum venting length for Category I appliances shall be determined per the NFGC (U.S.) or B149 (Canada).

The diameter of vent flue pipe should be sized according to the NFGC (U.S.) and B149 (Canada). The minimum flue pipe diameter for conventional negative draft venting using double-wall Type B vent is: 10 in. for Model 992B; 12 in. for Models 1262B and 1532B; 14 in. for Models 1802B, 2002B and 2072B; and 16 in. for 2342B.

NOTE: A vent adapter (field-supplied) must be used to connect Type B vent to the unit.

The connection from the appliance vent to the stack must be as direct as possible and shall be the same diameter as, or larger than, the vent outlet. The horizontal breaching of a vent must have an upward slope of not less than $1/4$ inch per linear foot from the heater to the vent terminal. The horizontal portions of the vent shall also be supported for the design and weight of the material employed to maintain clearances and to prevent physical damage or separation of joints.

Termination

The vent terminal should be vertical and should terminate outside the building at least 2 ft above the highest point of the roof that is within 8 ft. for Model 992B and 10 ft for all other models. The vent cap should have a minimum clearance of 4 ft horizontally from and in no

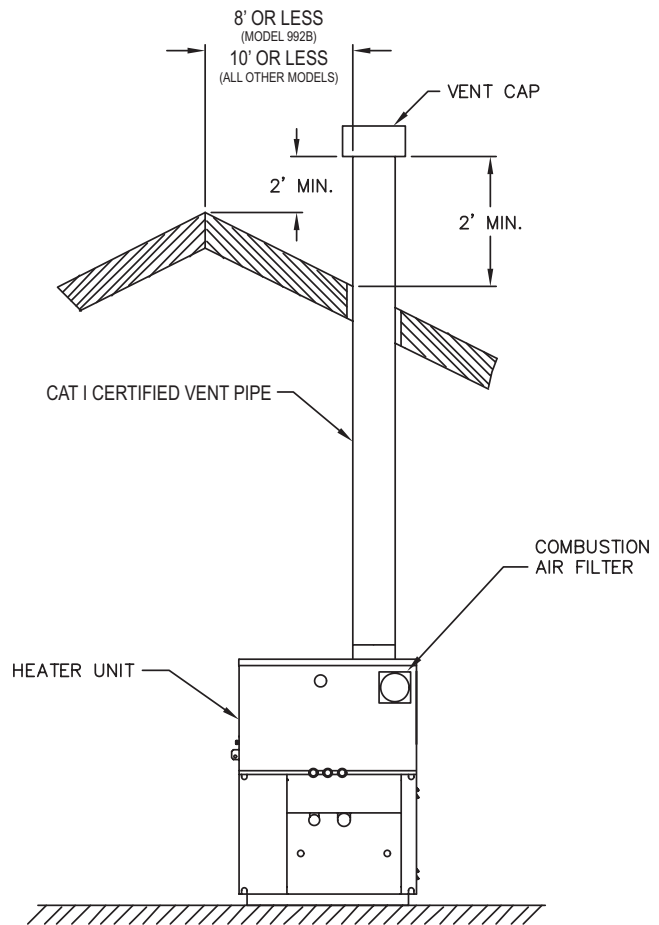

Fig. 29: Natural Draft Vertical Venting (Category I)

case above or below (unless a 4 ft horizontal distance is maintained) electric meters, gas meters, regulators and relief equipment. The distance of the vent terminal from adjacent public walkways, adjacent buildings, open windows and building openings must be consistent with the NFGC (U.S.) or B149 (Canada). Gas vents supported only by flashing and extended above the roof more than 5 ft should be securely guyed or braced to withstand snow and wind loads.

CAUTION: A listed vent cap terminal, adequately sized, must be used to evacuate the flue products from the heaters.

Common Venting System

Manifolds that connect more than one heater to a common chimney must be sized to handle the combined load. Consult available guides for proper sizing of the manifold and the chimney. At no time should the area of the common vent be less than the area of the largest heater exhaust outlet.

WARNING: Vent connectors serving appliances vented by natural draft shall not be connected into any portion of mechanical draft systems operating under a positive pressure.

CAUTION: Vent connectors for natural draft venting systems must be Type B or better.

Common venting systems may be too large once an existing unit is removed. At the time of removal of an existing appliance, **the following steps must be followed** with each appliance remaining connected to the common venting system placed in operation, while the other appliances remaining connected to the common venting system are not in operation.

1. Seal any unused opening in the common venting system.
2. Visually inspect the venting system for proper size and horizontal pitch and verify there is no blockage, restriction, leakage, corrosion or other unsafe condition.
3. Insofar as is practical, close all building doors and windows and all doors between the space in which the appliances remaining connected to the common venting system are located and other spaces of the building. Turn on clothes dryers and any appliance not connected to the common vent

system. Turn on any exhaust fans, such as range hoods and bathroom exhausts, at maximum-speed. Do not operate summer exhaust fan. Close fireplace dampers.

4. Place in operation the appliances being inspected. Follow the manufacturer's instructions for lighting each appliance. Adjust thermostat so appliance will operate continuously.
5. Check the pressure at a pressure tap located 12 in. above the bottom joint of the first vertical vent pipe. Pressure should be anywhere between -0.01 and -0.08 in. WC.
6. After it has been determined that each appliance remaining connected to the common venting system properly vents when tested as outlined above, return doors, windows, exhaust fans, fireplace dampers and other gas burning appliances to their previous conditions of use.
7. Any improper operation of the common venting system should be corrected so that the installation conforms with the NFGC (U.S.) or B149 (Canada). When re-sizing any portion of the common venting system, the common venting system should be re-sized to approach the minimum size as determined using the appropriate tables in the NFGC (U.S.) or B149 (Canada).

Model	Certified Venting Material	Vent Size	Vertical Venting Height*		Combustion Air Intake Pipe Material	Air Inlet Max. Length**	
			Min.	Max.		10"	12"
992B	Category I*** (Type B Equivalent)	10"	5'	25'	Galvanized Steel, PVC, ABS, CPVC	75'	100'
1262B		12"					
1532B		14"				40'	75'
1802B							
2002B							
2072B							
2342B		16"				40'	75'

* Vent lengths are based on a lateral length of 2 ft. Refer to the latest edition of the NFGC for further details.

When vertical height exceeds 25 ft, consult factory prior to installation.

** Subtract 10 ft per elbow. Max. 3 elbows.

*** Vertical direct vent applications require the use of positive pressure vent systems. Maximum combustion air duct length terminated at 100 equivalent ft.

Table M: Category I Vertical Venting

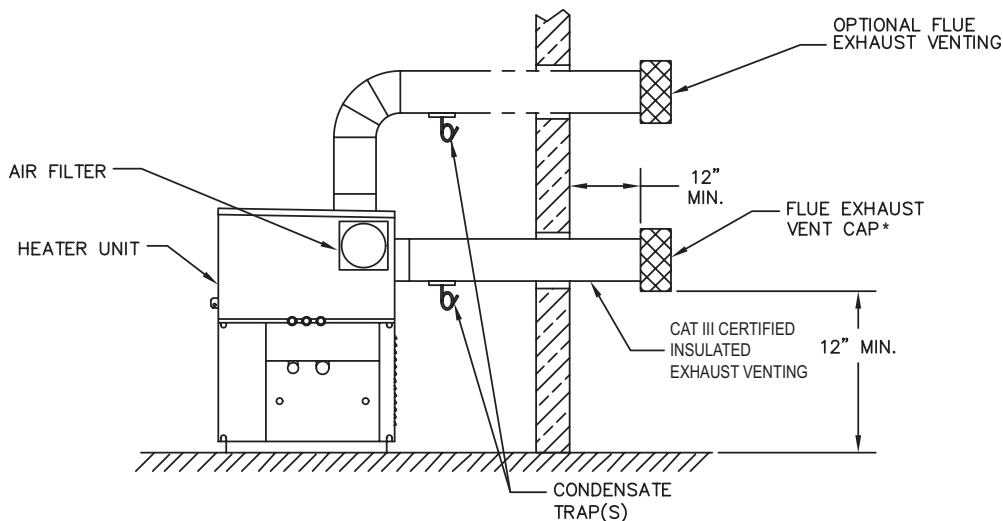

*Requires optional vent tee.

Fig. 30: Horizontal Through-the-Wall Venting (Category III)

Horizontal Through-the-Wall Venting (Category III)

Installation

These installations utilize the heater-mounted blower to vent the combustion products to the outdoors. Combustion air is taken from inside the room and the vent is installed horizontally through the wall to the outdoors. Adequate combustion and ventilation air must be supplied to the equipment room in accordance with the NFGC (U.S.) or B149 (Canada).

The total length of the horizontal through-the-wall flue system should not exceed 70 equivalent ft in length. If horizontal run exceeds 70 equivalent ft, an appropriately sized extractor must be used. Each elbow used is equal to 10 ft of straight pipe. This will allow installation in one of the four following arrangements:

- 70' of straight flue pipe
- 60' of straight flue pipe and one elbow
- 50' of straight flue pipe and two elbows
- 40' of straight flue pipe and three elbows

The vent cap is not considered in the overall length of the venting system.

The vent must be installed to prevent flue gas leakage. Care must be taken during assembly to ensure that all joints are sealed properly and are airtight. The vent must be installed to prevent the potential accumulation of condensate in the vent pipes. It is required that:

1. The vent must be installed with a slight downward slope of not more than 1/4 inch per foot of horizontal run to the vent terminal.
2. The vent must be insulated through the length of the horizontal run.

For installations in extremely cold climate, it is required that:

1. The vent must be installed with a slight upward slope of not more than 1/4 inch per foot of horizontal run to the vent terminal. In this case, an approved condensate trap must be installed per applicable codes.
2. The vent must be insulated through the length of the horizontal run.

Termination

The flue direct vent cap **MUST** be mounted on the exterior of the building. The direct vent cap cannot be installed in a well or below grade. The direct vent cap must be installed at least 1 ft above ground level and above normal snow levels. The Raypak-approved stainless steel flue direct vent cap **MUST** be used (sales order option D-15).

WARNING: No substitutions of flue pipe or vent cap material are allowed. Such substitutions would jeopardize the safety and health of inhabitants.

CAUTION: Condensate is acidic and highly corrosive.

Model No.	Certified Venting Material	Vent Size	Maximum Equivalent Vent Length*	Combustion Air Intake Pipe Material	Air Inlet Max. Length*	
					10"	12"
992B	Category III	10"	70' Room Air	Galvanized Steel, PVC, ABS, CPVC	75'	100'
1262B		12"				
1532B						
1802B		14"	40' Ducted Combustion Air		40'	75'
2002B						
2072B						
2342B						

* Subtract 10 ft per elbow. Max. 3 elbows.
Maximum combustion air duct length terminated at 100 equivalent ft.

Table N: Category III Horizontal and Direct Venting

Use only the special gas vent pipes listed for use with Category III gas burning heaters, such as the stainless steel vents offered by Heat Fab Inc. (800-772-0739), Protech System, Inc. (800-766-3473), Z-Flex (800-654-5600) or American Metal Products (800-423-4270). Pipe joints must be positively sealed. Follow the vent manufacturer's installation instructions carefully.

Direct Vent - Horizontal Through-the-Wall

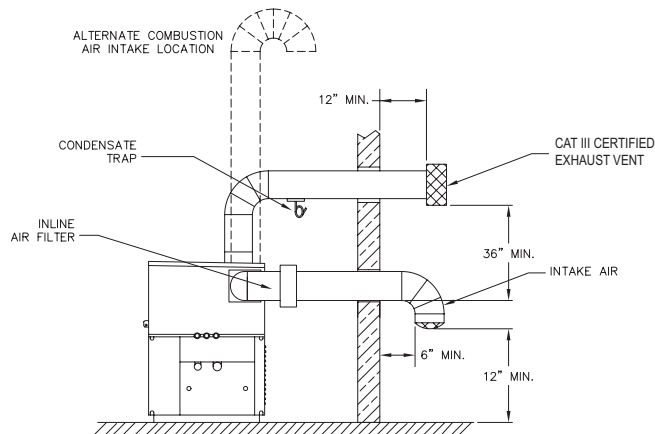

Note: When vertical height exceeds 25 ft, consult factory prior to installation.

Fig. 31: Direct Vent - Horizontal Through-the-Wall

Installation

These installations utilize the heater-mounted blower to draw combustion air from outdoors and vent combustion products to the outdoors.

The total length of the through-the-wall flue cannot exceed 40 equivalent ft in length for the flue outlet. Each elbow used is equal to 10 ft of straight pipe. This will allow installation in one of the three following arrangements:

- 40' of straight flue pipe
- 30' of straight flue pipe and one elbow
- 20' of straight flue pipe and two elbows.

The total length of air supply pipe cannot exceed the distances listed in Table N. Each elbow used is equal to 10 ft of straight pipe. This will allow installation in any arrangement that does not exceed the lengths shown in Table N.

The flue direct vent cap is not considered in the overall length of the venting system.

Care must be taken during assembly that all joints are sealed properly and are airtight.

The vent must be installed to prevent the potential accumulation of condensate in the vent pipes. It is required that:

1. The vent must be installed with a slight downward slope of not more than 1/4 inch per foot of horizontal run to the vent terminal.
2. The vent must be insulated through the length of the horizontal run.

For installations in extremely cold climate, it is required that:

1. The vent must be installed with a slight upward slope of not more than 1/4 inch per foot of horizontal run to the vent terminal. In this case, an approved condensate trap must be installed per applicable codes.
2. The intake vent must be insulated through the length of the horizontal run.

Termination

The flue direct vent cap **MUST** be mounted on the exterior of the building. The direct vent cap cannot be installed in a well or below grade. The direct vent cap must be installed at least 1 ft above ground level and above normal snow levels.

The direct vent cap **MUST NOT** be installed with any combustion air inlet directly above a direct vent cap. This vertical spacing would allow the flue products from the direct vent cap to be pulled into the combustion air intake installed above.

This type of installation can cause non-warrantable problems with components and poor operation of the heater due to the recirculation of flue products. Multiple direct vent caps should be installed in the same horizontal plane with a 4 ft clearance from the side of one vent cap to the side of the adjacent vent cap(s).

Combustion air supplied from outdoors must be free of particulate and chemical contaminants. To avoid a blocked flue condition, keep the vent cap clear of snow, ice, leaves, debris, etc.

WARNING: No substitutions of flue pipe or vent cap material are allowed. Such substitutions would jeopardize the safety and health of inhabitants.

The stainless steel flue direct vent cap **MUST** be furnished by the heater manufacturer in accordance with its listing (sales order option D-15).

Use only the special gas vent pipes listed for use with Category III gas burning heaters, such as the stainless steel vents offered by Heat Fab Inc. (800-772-0739), Protech System, Inc. (800-766-3473), Z-Flex (800-654-5600) or American Metal Products (800-423-4270). Pipe joints must be positively sealed. Follow carefully the vent manufacturer's installation instructions.

CAUTION: Condensate is acidic and highly corrosive.

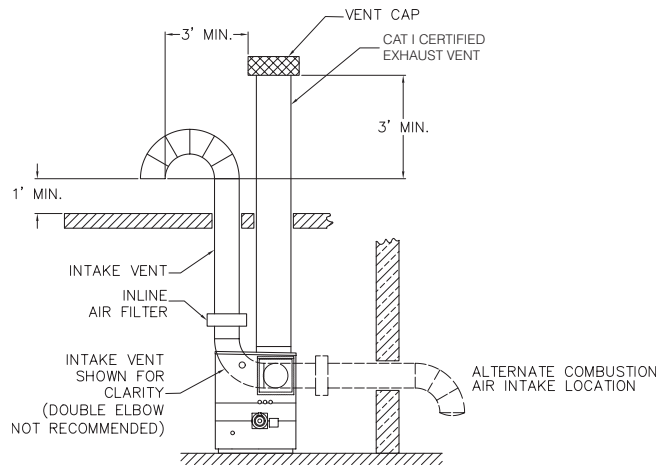

Note: When vertical height exceeds 25 ft, consult factory prior to installation.

Fig. 32: Direct Vent - Vertical

Direct Vent - Vertical

Installation

These installations utilize the heater-mounted blower to draw combustion air from outdoors and force the heated flue products through the vent pipe under positive pressure. The vent material must be in accordance with the above instructions for vent materials. Vent material must be listed by a nationally recognized test agency.

The connection from the appliance flue to the stack must be as direct as possible and should be the same size or larger than the vent outlet.

Use only the special gas vent pipes listed for use with Category III gas burning heaters, such as the stainless steel vents offered by Heat Fab Inc. (800-772-0739), Protech System, Inc. (800-766-3473), Z-Flex (800-654-5600) or American Metal Products (800-423-4270). Pipe joints must be positively sealed. Follow carefully the vent manufacturer's installation instructions.

See Table M for Category I venting guidelines.

It is recommended that in colder climates, the intake vent be insulated.

Termination

The flue terminal should be vertical and should terminate outside the building at least 2 ft above the highest point of the roof within 8 ft. for Model 992B or 10 ft. for all other models. The vent cap should have a minimum clearance of 4 ft horizontally from and in no case above or below (unless a 4 ft horizontal distance is maintained) electric meters, gas meters, regulators and relief equipment. The distance of the vent terminal from adjacent public walkways, adjacent buildings, open windows and building openings must be consistent with the NFGC (U.S.) or B149 (Canada).

Flues supported only by flashing and extended above the roof more than 5 ft should be securely guyed or braced to withstand snow and wind loads.

The air inlet opening MUST be installed 1 ft above the roof line or above normal snow levels that might obstruct combustion air flow. This dimension is critical to the correct operation of the heater and venting system and reduces the chance of blockage from snow. The vent cap must have a minimum 3 ft vertical clearance from the air inlet opening.

Outdoor Installation

Outdoor models are self-venting when installed with the optional factory-supplied outdoor vent kit and require no additional vent piping. A special vent cap, flow switch cover and air intake hood are provided in accordance with CSA requirements, which must be installed directly on the heater. Correct clearances can be found earlier in this section.

Care must be taken when locating the heater outdoors, because the flue gases discharged from the vent cap can condense as they leave the cap. Improper location can result in damage to adjacent structures or building finish. For maximum efficiency and safety, the following precautions must be observed:

1. Outdoor models must be installed outdoors and must use the outdoor vent cap, flow switch cover and air intake hood available from the manufacturer (sales order option D-11).
2. Periodically check venting system. The heater's venting areas must never be obstructed in any way and minimum clearances must be observed to prevent restriction of combustion and ventilation air. Keep area clear and free of combustible and flammable materials.

3. Do not locate adjacent to any window, door walkway, or gravity air intake. The vent must be located a minimum of 4 ft horizontally from such areas.
4. Install above grade level and above normal snow levels.
5. Vent terminal must be at least 3 ft above any forced air inlet located within 10 ft.
6. Adjacent brick or masonry surfaces must be protected with a rust-resistant sheet metal plate.

NOTE: Condensate can freeze on the vent cap. Frozen condensate on the vent cap can result in a blocked flue condition.

NOTE: The vent cap, flow switch cover and air intake hood must be furnished by the heater manufacturer in accordance with its listing (sales order option D-11).

Freeze Protection

When installing this heater in an outdoor location that is susceptible to freezing, sales order option B-22 must be ordered. The B-22 option energizes the heater pump at a preset temperature drop to circulate water and reduces the possibility of freezing and damaging the heat exchanger or headers.

Controls

WARNING: Installation, adjustment and service of heater controls, including timing of various operating functions, must be performed by a qualified installer, service agency or the gas supplier. Failure to do so may result in control damage, heater malfunction, property damage, personal injury, or death.

WARNING: Turn off the power to the heater before installation, adjustment or service of the CPW board or any heater controls. Failure to do so may result in board damage, heater malfunction, property damage, personal injury, or death.

CAUTION: This appliance has provisions to be connected to more than one supply source. To reduce the risk of electric shock, disconnect all such connections before servicing.

CAUTION: Risk of electric shock: More than one disconnect switch may be required to de-energize the equipment before servicing.

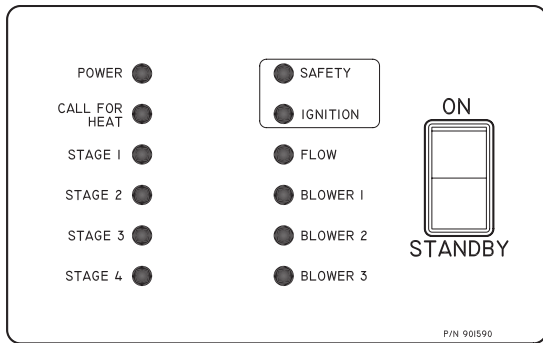

Fig. 33: Status LED Indicator Decal

Heater Sequence of Operation

Models 992B-1262B

1. The black (hot) wire lead goes directly to the main power switch. This black toggle switch is located at the middle front of the control compartment.
2. When the main power switch is placed in the “ON” position, 120 VAC is applied to the 120 VAC terminal block on the circuit board and the 120/24 VAC transformer is powered.
3. 120 VAC is waiting at the N.O. contacts of the Economaster pump delay.
4. Terminals L1 and F1 of the ignition module are powered with 120VAC.
5. 120 VAC power is also applied to the control power connector on the circuit board.
6. 120 VAC power is waiting at the N.O. contacts of K-3 relay to energize the heater blower.
7. The 120/24 VAC transformer outputs 24 VAC.
8. 24 VAC is sent to pin L1 of the low water cut-off (optional) and the red power light is energized.
9. 24 VAC is applied to the blue power light located on the status display board.
10. 24 VAC is also applied to the red LED safety shutdown light on the status display board until the safeties have been proven.
11. 24 VAC is applied to the alarm circuit (optional). If the E-5 sales option (Alarm) is included a 5 second time delay relay will not allow the alarm to sound unless a safety or limit circuit stays energized for more than 5 seconds.
12. Power is applied to terminal P1-1 of the Universal Diagnostics Board. 24 VAC power is then applied in series to all typically closed safeties wired into the heater. All safeties are verified to ensure that it is safe to operate the heater. The safety components wired into the diagnostic board are: low water cut-off (optional), blocked vent switch, manual vent temp switch (optional), manual reset high limit, low gas pressure switch, high gas pressure switch (optional), and auto-reset high limit (optional).
13. If any of the safeties do not close, a signal is sent to the Universal Diagnostics Board to indicate a safety fault.
14. Power is applied to terminal TP-1 of the Economaster pump delay to energize the circuit board.
15. Once all safeties are closed and verified, a 24 VAC signal is output from the Auto High Limit to J5 pin 3 of the CPW board of the heater.
16. 24 VAC power is now sent to the coil of relay K-1.
17. Relay K-1 (N.C.) will now be energized, and opens the N.C. contacts to disable the alarm (optional) and turns off the red LED safety shutdown light on the front status board.
18. The common terminal of the Auto High Limit will now send a 24 VAC signal to pin 1 of the “panel switch”.
19. The “panel switch” (rocker switch) located at the lower left front of the control compartment is now powered. If the switch is “ON” and there is no call for heat (CFH), the heater is in standby mode.
20. After the standby switch is placed into the “ON” position, a 24 VAC signal is sent to the “enable/disable” connection (normally jumpered).
21. 24 VAC switched power is applied to the S24V terminal on the ignition module.
22. When the “enable/disable” contacts are closed, the 24 VAC signal travels to pin 1 of the stage 1 connection and waits for a CFH.
23. When a CFH occurs, a 24 VAC signal is sent to the CFH light on the status panel located on the lower left front of the control compartment.

External Lights		
Light	Color	Indication
Power	Blue	Main power is on
Call For Heat	Yellow	Thermostat is closed
Safety	Red	One or more safeties is inoperative
Ignition	Red	Ignition module is inoperative
Flow	Green	Flow is present
Blower 1	Green	Blower 1 is on
Blower 2	Green	Blower 2 is on
Blower 3	Green	Blower 3 is on
Stage 1	Green	Stage 1 is on
Stage 2	Green	Stage 2 is on
Stage 3	Green	Stage 3 is on
Stage 4	Green	Stage 4 is on

Table O: Status LED Indicators

24. Power is also sent from pin 2 of the stage 1 connection to pin P1-3 of the universal diagnostic board.
25. Power is now sent to terminal TP4 of the Economaster to energize the relay and close the contacts.
26. Power is waiting at the common terminal of the flow switch waiting for closure and sufficient water flow.
27. The heater pump is energized upon relay closure of the Economaster.
28. Upon sufficient flow from the heater pump, the flow switch contacts will close.
29. If there is insufficient flow and the flow switch does not close, a 24 VAC signal is sent to the Universal Diagnostics Board to indicate the fault.
30. The flow light is energized; located on the front status panel.
31. A 24 VAC signal is also sent to the "TH" terminal located on the ignition module.
32. Once the 24 VAC "TH" signal is received at the ignition module, the internal contacts between F1 and F2 close sending a 120 VAC signal to the 120 VAC pilot duty terminals, located at J14 on the circuit board.
33. The 120 VAC signal continues to the coil of the blower relay K-3 (N.O.).
34. The 120 VAC signal continues to the 120 VAC safety terminals located at J13 on the circuit board.
35. When the coil on relay K-3 is powered, the N.O. relay contacts close and energize the blowers from the J8 connections on the CPW board.
36. After proper air pressure is received in the air plenum, the air pressure switches will close.
37. If there is insufficient air pressure and the air pressure switches do not close, a 24 VAC signal is sent to the Universal Diagnostics Board to indicate the fault.
38. A 24 VAC signal is now sent to the blower LED on the status board.
39. Power is applied to the optional equipment interlock connection (normally jumpered).
40. The 24 VAC signal is then sent to the 24 VAC safety connector.
41. 24 VAC is now sent to the pressure switch (P.S.) terminal on the ignition module.
42. Once the pressure switch signal is received at the ignition module, the heater performs a 15-second pre-purge, and then the hot surface igniter is ener-

-
- gized by a 120 VAC signal from S-1 on the ignition module for approximately 30 seconds. (The hot surface igniter must draw greater than 3.1 amps while being energized or ignition lockout will occur after three tries.)
43. Once the ignition module determines that the hot surface igniter has heated up and operating properly, a 24 VAC signal is output from pin GV on the module.
 44. 24 VAC signal is received at gas valve 1 thus energizing it.
 45. The stage 1 LED on the status display board is now illuminated.
 46. The coil of relay K-2 is now energized with the N.O. contacts closing downstream of the stage 2 and stage 3 connections.
 47. The gas coming through the burners should ignite from the heat of the hot surface igniter and the flame should carry over from one burner to the other burners of stage 1. The remote sensor is now trying to sense the flame. If the flame is not sensed within 4 seconds, the ignition module will shut down gas valve 1 and retry the hot surface igniter. During ignition retry, the heater must perform a 15-second pre-purge and an approximately 30-second igniter warm-up before opening gas valve 1 again. The standard ignition module will attempt ignition a maximum of three times prior to ignition lockout.
 48. If the ignition module locks out, a signal will be sent to the Universal Diagnostics Board to indicate an ignition fault.
 49. When power is sent to gas valve 1 it is also sent to time delay relay 1 (TD-1) which starts a 5-second countdown.
 50. After the 5-second countdown from TD-1, 24 VAC is waiting at pin 3 of the stage 2 connections on the CPW board.
 51. After closure of the stage 2 contacts Gas valve 2 is energized.
 52. The stage 2 LED on the status display board is now illuminated.
 53. Power is applied to pin 5 of the stage 3 connections on the CPW board.
 54. After closure of the stage 3 contacts, power is applied to TD-2.
 55. After a 5 second countdown TD-2 contacts close.
 56. Gas valve 3 then receives 24 VAC and is energized.
 57. The stage 3 LED on the status display board is now illuminated (end of sequence for 992B).
 58. Power is applied to pin 7 of the stage 4 connections on the CPW board.
 59. After closure of the stage 4 contacts, power is applied to TD-3 (1262B only).
 60. After a 5-second countdown TD-3 contacts close.
 61. Gas valve 4 (solenoid valve located in the front air plenum) then receives 24 VAC and is energized.
 62. The stage 4 LED on the status display board is now illuminated.
 63. The heater is now operating at full fire.
- ### **Models 1532B – 1802B**
1. The black (hot) wire lead goes directly to the main power switch. This black toggle switch is located at the middle front of the control compartment.
 2. When the main power switch is placed in the “ON” position, 120 VAC is applied to the 120 VAC terminal block on the circuit board and the 120/24 VAC transformer is powered.
 3. 120 VAC is waiting at the N.O. contacts of the Economaster pump delay.
 4. Terminals L1 and F1 of the ignition module are powered with 120VAC.
 5. 120 VAC power is also applied to the control power connector on the circuit board.
 6. 120 VAC power is waiting at the N.O. contacts of K-3 relay to energize the heater blowers.
 7. The 120/24 VAC transformer outputs 24 VAC.
 8. 24 VAC is sent to pin L1 of the low water cut-off (optional) and the red power light is energized.
-

-
9. 24 VAC is applied to the blue power light located on the status display board.
 10. 24 VAC is also applied to the red LED safety shutdown light on the front status board until the safeties have been proven.
 11. 24 VAC is applied to the alarm circuit (optional). If the E-5 sales option (Alarm) is included a 5-second time delay relay will not allow the alarm to sound unless a safety or limit circuit stays energized for more than 5 seconds.
 12. Power is applied to terminal P1-1 of the Universal Diagnostics Board. 24 VAC power is then applied in series to all typically closed safeties wired into the heater. All safeties are verified to ensure that it is safe to operate the heater. The safety components wired into the diagnostic board are: low water cut-off (optional), blocked vent switch, manual vent temp switch (optional), manual reset high limit, low gas pressure switch, high gas pressure switches (optional), and auto-reset high limit (optional).
 13. If any of the safeties do not close, a signal is sent to the Universal Diagnostics Board to indicate a safety fault.
 14. Power is applied to terminal TP-1 of the Economaster pump delay to energize the circuit board.
 15. Once all safeties are closed and verified, a 24 VAC signal is output from the Auto High Limit to J5 pin 3 of the CPW board of the heater.
 16. 24 VAC power is now sent to the coil of relay K-1.
 17. Relay K-1 (N.C.) will now be energized, and opens the N.C. contacts to disable the alarm (optional) and turns off the red LED safety shutdown light on the front status board.
 18. The common terminal of the Auto High Limit will now send a 24 VAC signal to pin 1 of the "panel switch".
 19. The "panel switch" (rocker switch) located at the lower left front of the control compartment is now powered. If the switch is "ON" and there is no call for heat (CFH), the heater is in standby mode.
 20. After the standby switch is placed into the "ON" position, a 24 VAC signal is sent to the "enable/disable" connection (normally jumpered).
 21. 24 VAC switched power is applied to the S24V terminal on ignition modules 1 and 2.
 22. When the "enable/disable" contacts are closed, the 24 VAC signal travels to pin 1 of the stage 1 connection and waits for a CFH.
 23. When a CFH occurs, a 24 VAC signal is sent to the CFH light on the status panel located on the lower left front of the control compartment.
 24. Power is also sent from pin 2 of the stage 1 connection to pin P1-3 of the universal diagnostic board.
 25. Power is now sent to terminal TP4 of the Economaster to energize the relay and close the contacts.
 26. Power is waiting at the common terminal of the flow switch waiting for closure and sufficient water flow.
 27. The heater pump is energized upon relay closure of the Economaster.
 28. Upon sufficient flow from the heater pump, the flow switch contacts will close.
 29. If there is insufficient flow and the flow switch does not close, a 24 VAC signal is sent to the Universal Diagnostics Board to indicate the fault.
 30. The flow light is energized; located on the front status panel.
 31. A 24 VAC signal is also sent to the "TH" terminal located on ignition module one.
 32. Once the 24 VAC "TH" signal is received at ignition module one, the internal contacts between F1 and F2 close sending a 120 VAC signal to the 120 VAC pilot duty terminals, located at J14 on the circuit board.
 33. The 120 VAC signal continues to the coil of the blower relay K-4 (N.O.).
 34. The 120 VAC signal continues to the 120 VAC safety terminals located at J13 on the circuit board.
 35. When the coil on relay K-4 is powered, the N.O. relay contacts close and energize the blowers from the J8 connections on the CPW board.
-

-
36. After proper air pressure is received in the air plenum, the air pressure switches will close.
 37. If there is insufficient air pressure and the air pressure switch does not close, a 24 VAC signal is sent to the Universal Diagnostics Board to indicate the fault.
 38. A 24 VAC signal is now sent to the blower LED's on the status board.
 39. Power is applied to the optional equipment interlock connection (normally jumpered).
 40. The 24 VAC signal is then sent to the 24 VAC safety connector.
 41. 24 VAC is now sent to the pressure switch (P.S.) terminal on the ignition modules.
 42. Once the pressure switch signal is received at ignition module one, the heater performs a 15 second pre-purge, then hot surface igniter one is energized by a 120 VAC signal from S-1 on ignition module one for approximately 30 seconds. (The hot surface igniter must draw greater than 3.1 amps while being energized or ignition lockout will occur after three tries.)
 43. Once ignition module one determines that hot surface igniter one has heated up and operating properly, a 24 VAC signal is output from pin GV on module one.
 44. 24 VAC signal is received at gas valve 1 thus energizing it.
 45. The stage 1 LED on the status display board is now illuminated.
 46. The coil of relay K-2 is now energized with the N.O. contacts closing downstream of the stage 2 and upstream of the stage 3 connections.
 47. The gas coming through the burners should ignite from the heat of hot surface igniter one and the flame should carry over from one burner to the other burners of stage 1. Remote flame sensor one is now trying to sense the flame. If the flame is not sensed within 4 seconds, the ignition module will shut down gas valve 1 and retry hot surface igniter one. During ignition retry the heater must perform a 15-second pre-purge and approximately a 30-second igniter warm-up before opening gas valve 1 again. The standard ignition module will attempt ignition a maximum of three times prior to ignition lockout.
 48. If ignition module one locks out, a signal will be sent to the Universal Diagnostics Board and to the status display board to indicate an ignition fault.
 49. When power is sent to gas valve 1 it is also sent to time delay relay 1 (TD-1) which starts a 5-second countdown.
 50. After the 5-second countdown from TD-1, 24 VAC is waiting at pin 3 of the stage 2 connections on the CPW board.
 51. After closure of the stage 2 contacts Gas valve 2 is energized.
 52. The stage 2 LED on the status display board is now illuminated.
 53. Power is applied to pin 5 of the stage 3 connections on the CPW board.
 54. The temperature controller closes the stage 3 contacts at J3 on the CPW board.
 55. Power is applied to the "TH" terminal of ignition module 2.
 56. Once the "TH" signal is received at ignition module 2, the heater performs a 15 second pre-purge, then hot surface igniter 2 is energized by a 120 VAC signal from S-1 on ignition module 2 for approximately 30 seconds. (The hot surface igniter must draw greater than 3.1 amps while being energized or ignition lockout will occur after three tries.)
 57. Once ignition module 2 determines that hot surface igniter two is operating properly, a 24 VAC signal is sent to energize gas valve 3.
 58. The stage 3 LED on the status display board is now illuminated.
 59. The gas coming through the stage 3 burners should ignite from the heat of hot surface igniter two and the flame should carry over from one burner to the other burners of stage 3. Remote flame sensor two is now trying to sense the flame. If the flame is not sensed within 4 seconds, the ignition module will shut down gas valve 3 and retry the hot surface igniter. During ignition retry the heater must perform a 15-second pre-purge and approximately a 30-second igniter warm-up before opening gas valve 3 again. The standard ignition module will attempt ignition a maximum of three times prior to ignition lockout.
-

-
60. If ignition module two locks out, a signal will be sent to the Universal Diagnostics Board and to the status display board to indicate an ignition fault.
 61. The coil of relay K-5 (N.O.) is now energized with the (K-5) contacts closing downstream of the stage 4 connections.
 62. Power is now applied to time delay relay 3 and the contacts of TD-3 close after 5 seconds.
 63. The stage 4 controller contacts close.
 64. Power is applied to gas valve 4.
 65. The stage 4 LED on the status display board is now illuminated.
 66. The heater is operating at full fire.

Models 2002B – 2342B

1. The black (hot) wire lead goes directly to the main power switch. This black toggle switch is located at the middle front of the control compartment.
2. When the main power switch is placed in the “ON” position, 120 VAC is applied to the 120 VAC terminal block on the circuit board and the 120/24 VAC transformer is powered.
3. 120 VAC is waiting at the N.O. contacts of the Economaster pump delay.
4. Terminals L1 and F1 of the ignition module are powered with 120VAC.
5. 120 VAC power is also applied to the control power connector on the circuit board.
6. 120 VAC power is waiting at the N.O. contacts of K-3 relay to energize the heater blower.
7. The 120/24 VAC transformer outputs 24 VAC.
8. 24 VAC is sent to pin L1 of the low water cut-off (optional) and the red power light is energized.
9. 24 VAC is applied to the blue power light located on the status display board.
10. 24 VAC is also applied to the red LED safety shutdown light on the front status board until the safeties have been proven.
11. 24 VAC is applied to the alarm circuit (optional). If the E-5 sales option (Alarm) is included a 5 second time delay relay will not allow the alarm to sound unless a safety or limit circuit stays energized for more than 5 seconds.
12. Power is applied to terminal P1-1 of the Universal Diagnostics Board. 24 VAC power is then applied in series to all typically closed safeties wired into the heater. All safeties are verified to ensure that it is safe to operate the heater. The safety components wired into the diagnostic board are: low water cut-off (optional), blocked vent switch, manual vent temp switch (optional), manual reset high limit, low gas pressure switch, high gas pressure switches (optional), and auto-reset high limit (optional).
13. If any of the safeties do not close, a signal is sent to the Universal Diagnostics Board to indicate a safety fault.
14. Power is applied to terminal TP-1 of the Economaster pump delay to energize the circuit board.
15. Once all safeties are closed and verified, a 24 VAC signal is output from the Auto High Limit to J5 pin 3 of the CPW board of the heater.
16. 24 VAC power is now sent to the coil of relay K-1.
17. Relay K-1 (N.C.) will now be energized, and opens the N.C. contacts to disable the alarm (optional) and turns off the red LED safety shutdown light on the front status board.
18. The common terminal of the Auto High Limit will now send a 24 VAC signal to pin 1 of the “panel switch”.
19. The “panel switch” (rocker switch) located at the lower left front of the control compartment is now powered. If the switch is “ON” and there is no call for heat (CFH), the heater is in standby mode.
20. After the standby switch is placed into the “ON” position, a 24 VAC signal is sent to the “enable/disable” connection (normally jumpered).
21. 24 VAC switched power is applied to the S24V terminal on ignition modules 1 and 2.
22. When the “enable/disable” contacts are closed, the 24 VAC signal travels to pin 1 of the stage 1 connection and waits for a CFH.

-
23. When a CFH occurs, a 24 VAC signal is sent to the CFH light on the status panel located on the lower left front of the control compartment.
 24. Power is also sent from pin 2 of the stage 1 connection to pin P1-3 of the universal diagnostic board.
 25. Power is now sent to terminal TP4 of the Economaster to energize the relay and close the contacts.
 26. Power is waiting at the common terminal of the flow switch waiting for closure and sufficient water flow.
 27. The heater pump is energized upon relay closure of the Economaster.
 28. Upon sufficient flow from the heater pump, the flow switch contacts will close.
 29. If there is insufficient flow and the flow switch does not close, a 24 VAC signal is sent to the Universal Diagnostics Board to indicate the fault.
 30. The flow light is energized; located on the front status panel.
 31. A 24 VAC signal is also sent to the "TH" terminal located on ignition module one.
 32. Once the 24 VAC "TH" signal is received at ignition module one, the internal contacts between F1 and F2 close sending a 120 VAC signal to the 120 VAC pilot duty terminals, located at J14 on the circuit board.
 33. The 120 VAC signal continues to the coil of the blower relay K-4 (N.O.).
 34. The 120 VAC signal continues to the 120 VAC safety terminals located at J13 on the circuit board.
 35. When the coil on relay K-4 is powered, the N.O. relay contacts close and energize the blowers from the J8 connections on the CPW board.
 36. After proper air pressure is received in the air plenum, the air pressure switches will close.
 37. If there is insufficient air pressure and the air pressure switch does not close, a 24 VAC signal is sent to the Universal Diagnostics Board to indicate the fault.
 38. A 24 VAC signal is now sent to the blower LED's on the status board.
 39. Power is applied to the optional equipment interlock connection (normally jumpered).
 40. The 24 VAC signal is then sent to the 24 VAC safety connector.
 41. 24 VAC is now sent to the pressure switch (P.S.) terminal on the ignition modules.
 42. Once the pressure switch signal is received at ignition module one, the heater performs a 15-second pre-purge, then hot surface igniter one is energized by a 120 VAC signal from S-1 on ignition module one for approximately 30 seconds. (The hot surface igniter must draw greater than 3.1 amps while being energized or ignition lockout will occur after three tries.)
 43. Once ignition module one determines that hot surface igniter one has heated up and operating properly, a 24 VAC signal is output from pin GV on module one.
 44. 24 VAC signal is received at gas valve 1 thus energizing it.
 45. The stage 1 LED on the status display board is now illuminated.
 46. The coil of relay K-2 is now energized with the N.O. contacts closing downstream of the stage 2 and upstream of the stage 3 connections.
 47. The gas coming through the burners should ignite from the heat of hot surface igniter one and the flame should carry over from one burner to the other burners of stage 1. Remote flame sensor one is now trying to sense the flame. If the flame is not sensed within 4 seconds, the ignition module will shut down gas valve 1 and retry hot surface igniter one. During ignition retry the heater must perform a 15-second pre-purge and approximately a 30-second igniter warm-up before opening gas valve 1 again. The standard ignition module will attempt ignition a maximum of three times prior to ignition lockout.
 48. If ignition module one locks out, a signal will be sent to the Universal Diagnostics Board and to the status display board to indicate an ignition fault.
-

-
49. When power is sent to gas valve 1 it is also sent to time delay relay 1 (TD-1) which starts a 5-second countdown.
 50. After the 5-second countdown from TD-1 and the internal contacts close, time delay relay 2 (TD-2) receives 24 VAC.
 51. Gas valve 1a is energized allowing the remainder of stage 1 to fire.
 52. After the 5-second countdown from TD-2 the internal contacts close allowing 24 VAC to sit at pin 3 of the stage 2 connection on the CPW board.
 53. After closure of the stage 2 contacts Gas valve 2 is energized.
 54. The stage 2 LED on the status display board is now illuminated.
 55. The temperature controller closes the stage 3 contacts at J3 on the CPW board.
 56. Power is applied to pin 5 of the stage 3 connections on the CPW board.
 57. Power is applied to the "TH" terminal of ignition module 2.
 58. Once the "TH" signal is received at ignition module 2, the heater will perform a 15-second pre-purge, and then hot surface igniter 2 is energized by a 120 VAC signal from S-1 on ignition module 2 for approximately 30 seconds. (The hot surface igniter must draw greater than 3.1 amps while being energized or ignition lockout will occur after three tries.)
 59. If ignition module two locks out, a signal will be sent to the Universal Diagnostics Board and to the status display board to indicate an ignition fault.
 60. Once the ignition module determines that the hot surface igniter has heated up and operating properly, a 24 VAC signal is output from pin GV on the module.
 61. 24 VAC signal is received at gas valve 3 thus energizing it.
 62. The stage 3 LED on the status display board is now illuminated.
 63. The coil of relay K-5 (N.O.) is now energized with the (K-5) contacts closing downstream of the stage 4 connections.
 64. Remote flame sensor 2 is trying to rectify flame.
 65. Power is now applied to time delay relay 3 and the contacts of TD-3 located upstream of the stage 4 connection close after 5 seconds.
 66. The stage 4 controller contacts close.
 67. Power is applied to gas valve 4.
 68. The stage 4 LED on the status display board is now illuminated.
 69. The heater is now operating at full fire.
-

Ignition Module

When additional heat is needed, the combustion air blower starts to purge air from the combustion chamber for about 15 seconds. On proof-of-air flow, the air-

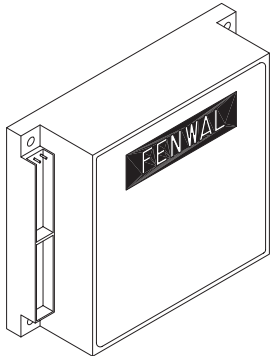

Fig. 34: Ignition Module

proving switch closes and the igniter is energized. To ensure safe operation, the gas valve cannot open until the igniter is verified. The main burner is automatically lit when the device is powered and pre-purged. The heater performs its own safety check and opens the main valve only after the igniter is proven to be capable of ignition.

The standard ignition module will attempt to light three times before locking out. To reset it, turn off power to the heater, wait 30 seconds and re-apply power.

The optional single-try ignition module will lock out after failing to light one time. To reset it, press and release the small, recessed black push button located inside of the cut-out on the lower right-hand corner of the ignition module case. Turning off the power to the heater WILL NOT reset the ignition module.

High Limit (Manual Reset)

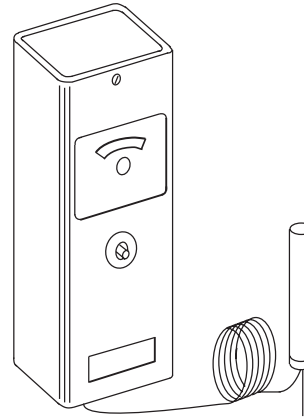

Fig. 35: High Limit (Manual Reset)

The heater is equipped with a manual reset high limit temperature device. Push the reset button and adjust the setting to 40 - 50°F above desired operating temperature. Typically, the maximum settings are 240°F for H units and 200°F for WH units.

Flow Switch

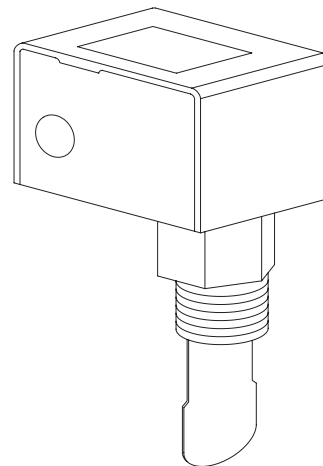

Fig. 36: Flow Switch

This dual-purpose control, mounted and wired in series with the main gas valve, shuts off heater in case of pump failure or low water flow.

Operating Control

The heater may be equipped with different types of operating controls. Consult the individual control data

Code	Condition
On	System OK No faults present
Off	Possible control fault Check power
1 Flash	Low air pressure, brief flashing normal on startup
2 Flashes	Flame in combustion chamber, no Call For Heat
3 Flashes	Ignition lockout
4 Flashes	Low igniter current
5 Flashes	Low 24 VAC, check control supply voltage
6 Flashes	Internal fault Replace module

Table P: Ignition Module Diagnostic LED Codes

sheets supplied with your heater paperwork. See the General Safety Section for safety precautions concerning domestic hot water applications.

Low Water Cut-Off (Optional)

The low water cut-off automatically shuts down the burner whenever water level drops below the level of the sensing probe. A 5-second time delay prevents premature lockout due to temporary conditions such as power fluctuations or air pockets.

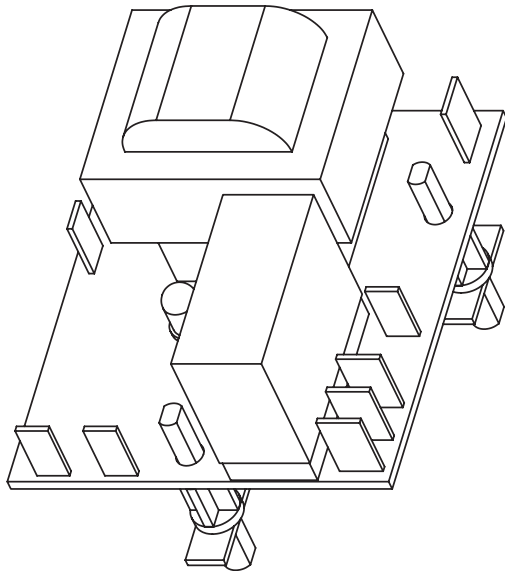

Fig. 37: Low Water Cut-Off

High and Low Gas Pressure Switches

The low gas pressure switch (standard) connection mounts upstream of the gas valve to ensure that sufficient gas pressure is present for proper regulator performance. The low gas pressure switch automatically shuts down the heater if gas supply drops below the factory setting of 5.0 in. WC for natural gas, and 10.0 in. WC for propane gas.

The high gas pressure switch (optional) connection mounts down-stream of the stage-1 gas valve. If the gas pressure regulator fails, the high gas pressure switch automatically shuts down the burner. The high gas pressure switch automatically shuts down the heater if gas manifold pressure rises above the recommended setting of 5.0 in. WC for natural gas, and 11.5 in. WC for propane gas.

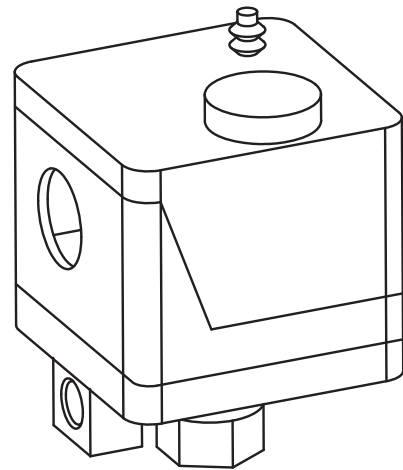

Fig. 38: High/Low Gas Pressure Switch

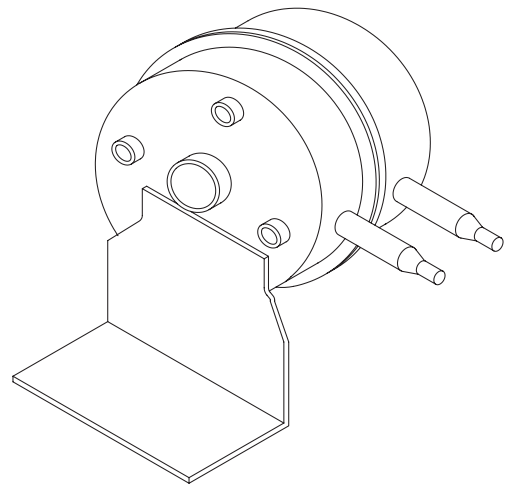

Fig. 39: Fan-Proving Switch

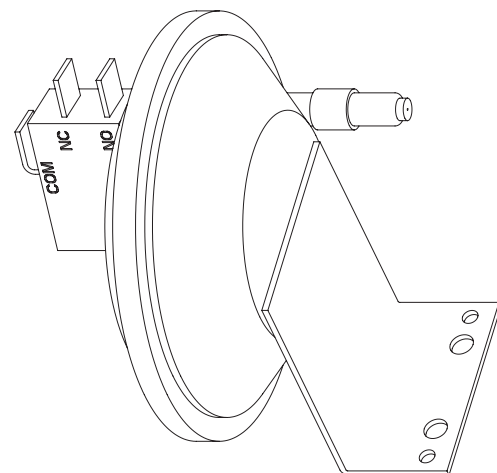

Fig. 40: Blocked Vent Switch

Pump Time Delay

The Economaster is a fully enclosed solid state TDR with a white jumper that selects one of two time delays. See Fig. 41. If the jumper is on pins 6 and 7 (default) the delay time is 5 minutes. If the jumper is not on pins 6 and 7, the time delay is 10 minutes.

In a conventional system, when the temperature control is satisfied, the main gas valve(s) closes, but the pump continues operating. With the time delay relay, the boiler pump is programmed to continue running for an optimum period of time in order to absorb the residual heat from the combustion chamber and use it in the system. The pump then shuts off until the next call for heat is received from the temperature control.

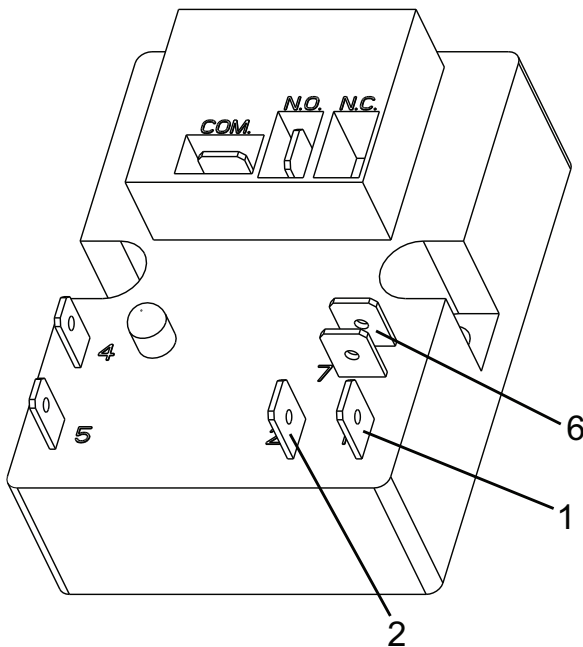

Fig. 41: Economaster Time Delay Relay (TDR)

UDB Diagnostic Board

This heater is equipped with a diagnostic board which will indicate faults as they occur. Refer to the following section for instructions on accessing, reviewing and clearing these faults.

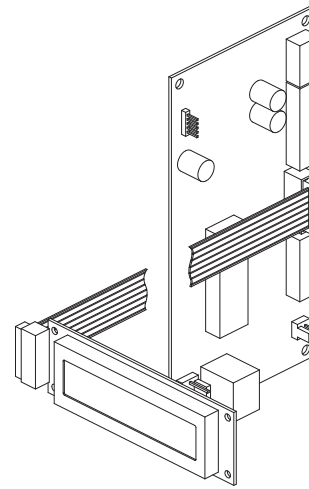

Fig. 42: UDB Diagnostic Board

UDB Fault History

To view the fault codes in the UDB history file:

1. Press the **UP** or **DOWN** buttons on the membrane switch for 2 seconds to access the fault history.
2. Press either button to scroll through the recorded faults in history.
3. The most recent fault recorded will be the first fault displayed (the last 16 faults are stored in the history, on a rolling basis). There is no time or date stamp associated with these faults.
4. When the history of faults has been exhausted, pushing the **UP** or **DOWN** buttons again will roll the fault history over and it will start again.
5. To exit the fault history, wait for 10 seconds and the board will automatically exit the history mode.

To clear the fault history, press and hold **both** the **UP** and **DOWN** buttons for 5 seconds while the power is on.

NOTE: Once the history has been cleared, it cannot be recovered.

Diagnostic information is provided any time a fault is recorded. This information is intended to assist in locating the problem with the heater, but is not exhaustive.

If multiple fault conditions occur at the same time, only the fault that caused the heater to shut down will be recorded in the history.

Hi Delta	Detection Delay	LCD Display Readout with Fault
PVC Vent Limit-CHX	1	Cond Drain Blocked/Vent Temp Limit Err Check Drain Switch, Check Drain/Check Vent System
Manual High Limit	1	Man Hi Limit Fault Confirm Settings, Reset Hi Limit
Auto High Limit	1	Auto Hi Limit Fault Confirm Settings, Check Pump
Low Water Cut-off	1	Low Water Cutoff Err Purge Air, Check Pump, Check Isolation Valve, Reset LWCO
Vent Pressure	1	Vent Pressure Fault Blocked Vent, Check Vent System
Low Gas Pressure	1	Lo Gas Press Fault Confirm Settings, Check Supply Gas, Reset LGPS
High Gas Pressure	1	Hi Gas Press Fault Confirm Settings, Check Supply Gas
Controller Alarm	1	Controller Alarm See Control Display
Flow Switch	3	Water Flow Sw Fault Check Boiler Pump, Purge Air, Replace Flow Switch
Blower Switch	3	Blower Air Sw Fault Check Air Filter, Check Blower, Check Air Sw hose
Factory Option	3	Factory Option Fault Check Factory Data, Check Wiring Diagram, Check Freeze Control, Check Water Pressure
External Interlock	90	Field Interlock Err Check Louvers, Check Comb Damper, Check Extractor Sw.
CWS/CWR	3	CWS/CWR Fault Confirm Inlet Temp, Reset CWS/CWR Control
Ignition Lockout	1	Ignition Lockout Display actual Flash Code Recycle/Reset Control, Push Reset Button See Table Below

Field Interlock # Flashes	Fault	LCD Display Readout with Fault
1	Low Air	Low Air Fault Check Blower, Check Filter, Check Air Sw Hose
2	Flame - No CFH	Flame - No CFH Shut Off Gas Supply, Recycle Power
3	Ignition Lockout	Ignition Lockout Recycle/Reset Cntrl, Push Reset Button
4	Low HSI Current	Low HSI Current Check HSI Current, Replace HSI, Recycle Power, Replace Ign
5	Low 24 VAC	Low 24 VAC Check Power Supply, Check Transformer
6	Internal Cntrl Fault	Internal Cntrl Fault Recycle/Reset Cntrl, Replace Control

Condition	LCD Display without Fault
Power On / No CFH	System Normal
	Standby / Website*
Power On / CFH	System Normal
	CFH Active / Website*

* Toggles Between /

Table Q: UDB Fault Messages

87%-Efficiency Boilers – Special Instructions

NOTE: The constructions of the 84%- (standard) and 87%-efficiency (optional) boilers are very similar, and they are installed to the same requirements, except as noted in this section.

Water Piping

An 87%-efficiency boiler requires a minimum inlet water temperature of 120°F (49°C) to prevent excessive condensation in the combustion chamber. An 87%-efficiency boiler operated with an inlet temperature of less than 120°F (49°C) must have a manual bypass or an approved low-temperature operation system to prevent problems with condensation. A manual bypass, shown in Fig. 15, must be piped into the system at the time of installation. This piping is like a primary/secondary boiler installation with a bypass in the secondary boiler piping. Raypak strongly recomm-

ends that a thermometer be placed into the boiler inlet piping next to the in/out header to facilitate temperature adjustment. Inlet water temperatures below 120°F (49°C) can excessively cool the products of combustion, resulting in condensation on the heat exchanger.

Venting

CAUTION: Proper installation of flue venting is critical for the safe and efficient operation of the boiler.

CAUTION: Condensate is acidic and highly corrosive.

Appliance Categories

See Table S for appliance category requirements for the 87%-efficiency Hi Delta.

NOTE: For additional information on appliance categorization, see appropriate code NFGC (U.S.) and B149 (Canada), or applicable local building codes.

Model No.	20°FΔT		30°FΔT		40°FΔT		Min. Flow			Max. Flow		
	GPM	ΔP (ft)	GPM	ΔP (ft)	GPM	ΔP (ft)	GPM	ΔP (ft)	ΔT	GPM	ΔP (ft)	ΔT
992BE	86	5.6	57	2.5	43	1.4	43	1.4	40	132	13.1	13
1262BE	110	10.3	73	4.6	55	2.6	55	2.6	40	132	14.8	17
1532BE	132	16.5	89	7.6	67	4.3	67	4.3	40	132	16.5	20
1802BE	N/A	N/A	104	11.5	78	6.5	78	6.5	40	132	18.3	24
2002BE	N/A	N/A	116	14.8	87	8.5	87	8.5	40	132	19.0	26
2072BE	N/A	N/A	120	15.8	90	9.1	90	9.1	40	132	19.0	27
2342BE	N/A	N/A	N/A	N/A	102	12.9	102	12.9	40	132	21.4	31

Note: Basis for minimum flow is 40°F ΔT. Basis for maximum flow is 132 GPM.

Table R: Heater Rate of Flow and Pressure Drop

Combustion Air Supply	Exhaust Configuration	Heater Venting Category	Certified Materials	Combustion Air Inlet Material
From Inside Building (Non-Direct Venting)	Vertical Negative Draft	II	Stainless Steel	
	Horizontal Positive Pressure	IV	Stainless Steel (Gas Tight)	
From Outside Building (Direct Venting)	Vertical Negative Draft	II	Stainless Steel	Galvanized Steel PVC ABS CPVC
	Horizontal Positive Pressure	IV	Stainless Steel (Gas Tight)	

Table S: Category Determination for Venting Purpose and Venting Arrangement

WARNING: Contact the vent material manufacturer if there are any questions about the appliance category or suitability of a vent material for Category II, III or IV applications. Using improper venting materials can result in personal injury, death or property damage.

Vent Terminal Location

NOTE: During winter months check the vent cap and make sure no blockage occurs from build-up of snow or ice.

1. Condensate can freeze on the vent cap. Frozen condensate on the vent cap can result in a blocked flue condition.
2. Give special attention to the location of the vent termination to avoid possibility of property damage or personal injury.
3. Gases may form a white vapor plume in winter. The plume could obstruct a window view if the termination is installed near windows.
4. Prevailing winds, in combination with below-freezing temperatures, can cause freezing of condensate and water/ice build-up on building, plants or roof.
5. The bottom of the vent terminal and the air intake shall be located at least 12 in. above grade, including normal snow line.
6. Un-insulated single-wall metal vent pipe shall NOT be used outdoors in cold climates for venting gas utilization equipment.
7. Through-the-wall vents for Category II and IV appliances shall not terminate over public walkways or areas where condensate or vapor could create a nuisance or hazard, or be detrimental to the operation of regulators, relief valves or other equipment.
8. Locate and guard vent termination to prevent accidental contact by people or pets.
9. DO NOT terminate vent in window well, stairwell, alcove, courtyard or other recessed area, unless previously approved by local authority.
10. DO NOT terminate above any door, window, or gravity air intake. Condensate can freeze, causing ice formations.

11. Locate or guard vent to prevent condensate from damaging exterior finishes. Install a rust-resistant sheet metal backing plate against brick or masonry surfaces.
12. DO NOT extend exposed vent pipe outside of building. Condensate could freeze and block vent pipe.

Condensate Management

Condensate must be routed from the condensate trap to an appropriate container for neutralization before disposal, as required by local codes. Note that condensate is acidic and highly corrosive.

Vertical Venting (Category II)

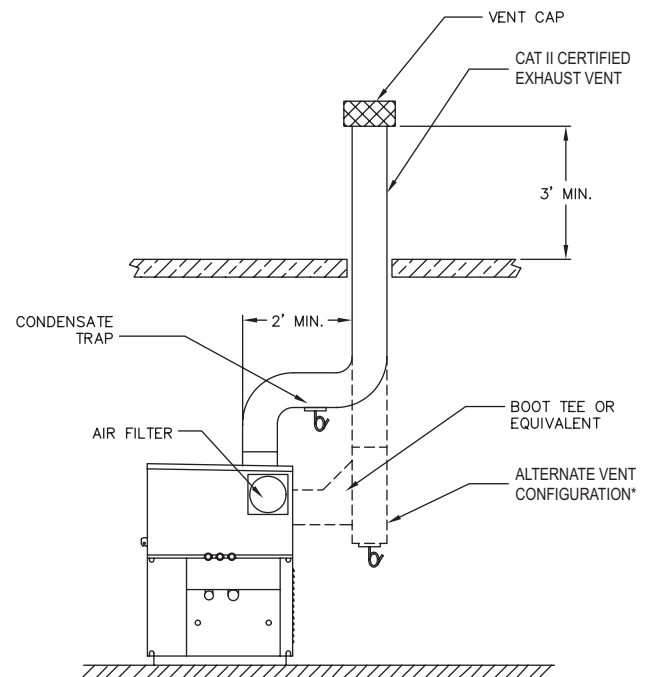

Note: When vertical height exceeds 25 ft, consult factory prior to installation.

*Requires optional vent tee.

Fig. 43: Vertical Venting (Category II)

CAUTION: A properly sized listed vent cap terminal must be used to evacuate the flue products from the boilers.

Common Venting System

Manifolds that connect more than one boiler to a common chimney must be engineered to handle the combined load. Consult available guides for proper sizing of the manifold and the chimney. At no time should the area of the vent be less than the area of the largest boiler exhaust outlet.

WARNING: Vent connectors serving appliances vented by natural draft shall not be connected into any portion of mechanical draft systems operating under a positive pressure.

Horizontal Through-the-Wall Venting (Category IV)

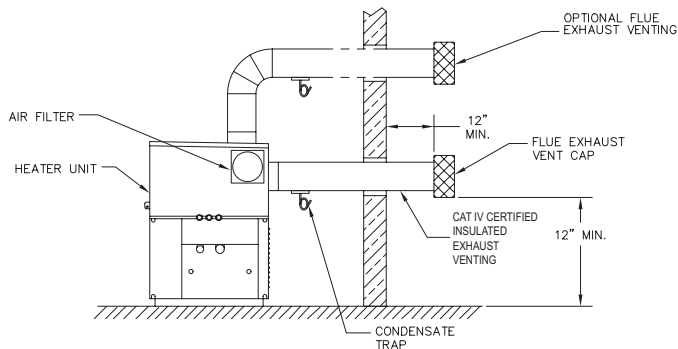

*Requires optional vent tee.

Fig. 44: Horizontal Through-the-Wall Venting (Category IV)

Installation

These installations utilize the boiler-mounted blower to vent the combustion products to the outdoors. Combustion air is taken from inside the room and the vent is installed horizontally through the wall to the outdoors. Adequate combustion and ventilation air must be supplied to the mechanical room in accordance with the NFGC (U.S.) and B149 (Canada).

The total length of the horizontal through-the-wall exhaust vent system should not exceed 70 ft in length. If horizontal run exceeds 70 ft, an appropriately sized extractor must be used. To maintain proper operation,

pressure reading must be between -0.01 and -0.1 in. WC as measured 12 in. from the appliance flue outlet. Each elbow used is equal to 10 ft of straight pipe. This will allow installation in one of the four following combinations:

- 70' of straight flue pipe
- 60' of straight flue pipe and one elbow
- 50' of straight flue pipe and two elbows
- 40' of straight pipe and three elbows

The vent cap is not considered in the overall length of the venting system.

The vent must be installed to prevent flue gas leakage. Care must be taken during assembly to ensure that all joints are sealed properly and are airtight. The vent must be installed to prevent the potential accumulation of condensate in the vent pipes. It is recommended that:

1. The vent must be installed with a slight upward slope of not more than 1/4 in per foot of horizontal run to the vent terminal.
2. The vent must be insulated through the length of the horizontal run.

Common Venting System

Common venting of Category IV systems is not allowed.

WARNING: No substitutions of flue pipe or vent cap material are allowed. Such substitutions would jeopardize the safety and health of inhabitants.

Model	Certified Venting Material	Vent Size	Maximum Equivalent Vent Length*	Combustion Air Intake Pipe Material	Air Inlet Max. Length*	
					10"	12"
992BE	Category II or IV	10"	70' Room Air	Galvanized Steel, PVC, ABS, CPVC	75'	100'
1262BE		12"				
1532BE		14"	40' Ducted Combustion Air		40'	75'
1802BE						
2002BE						
2072BE						
2342BE		16"				

* Subtract 10 ft per elbow. Max. 3 elbows.
Maximum combustion air duct length terminated at 100 equivalent ft.

Table T: Category II and IV Venting

The stainless steel direct vent cap **MUST** be furnished by the boiler manufacturer in accordance with its listing (sales order option D-15).

Use only double-wall vent pipe and the special gas vent pipes listed for use with category II or IV gas burning boilers, such as the stainless steel Saf-T vent by Heat Fab Inc. (800-772-0739), Protech Systems Inc. (800-766-3473), Z-Flex (800-654-5600) or American Metal Products (800-423-4270). Pipe joints must be positively sealed. Follow the vent manufacturer's installation instructions carefully.

Direct Vent - Horizontal Through-the-Wall

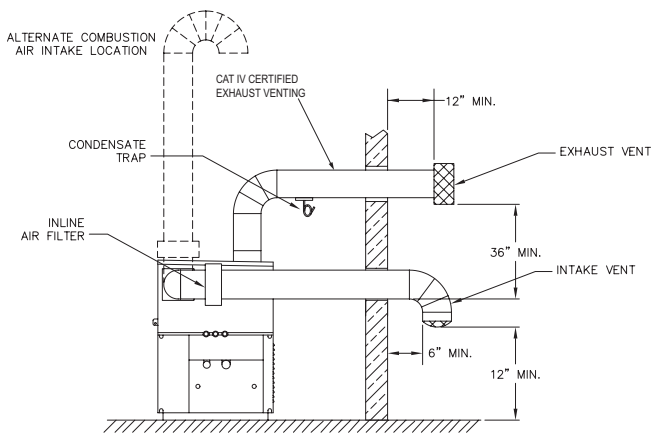

Fig. 45: Direct Vent - Horizontal Through-the-Wall

Installation

These installations utilize the boiler-mounted blower to draw combustion air from outdoors and vent combustion products to the outdoors.

The total length of the direct vent through-the-wall exhaust vent cannot exceed 40 ft in length for the flue outlet. Each elbow used is equal to 10 ft of straight pipe. This will allow installation in one of the three following combinations:

- 40' of straight flue pipe
- 30' of straight flue pipe and one elbow
- 20' of straight flue pipe and two elbows

The total length air supply duct cannot exceed the distances listed. Each elbow used is equal to 10 ft of straight pipe. This will allow installation in one of the three following combinations:

- 40' of straight combustion air pipe
- 30' of straight combustion air pipe and one elbow
- 20' of straight combustion air pipe and two elbows

The flue exhaust direct vent cap is not considered in the overall length of the venting system.

Care must be taken during assembly that all joints are sealed properly and are airtight.

The vent must be installed to prevent the potential accumulation of condensate in the vent pipes. It is recommended that:

1. The vent must be installed with a slight downward slope of not more than 1/4 inch per foot of horizontal run to the vent terminal.
2. The vent must be insulated through the length of the horizontal run.

For installations in extremely cold climate, it is recommended that:

1. The vent must be installed with a slight upward slope of not more than 1/4 inch per foot of horizontal run to the vent terminal. In this case, an approved condensate trap must be installed per applicable codes.
2. The intake vent must be insulated through the length of the horizontal run.

Common Venting System

Common venting of Category IV systems is not allowed.

WARNING: No substitutions of flue pipe or vent cap material are allowed. Such substitutions would jeopardize the safety and health of inhabitants.

The stainless steel flue exhaust direct vent cap **MUST** be furnished by the boiler manufacturer in accordance with its listing (sales order option D-15).

Use only double-wall vent pipe and the special gas vent pipes listed for use with category II or IV gas burning boilers, such as the stainless steel Saf-T vent by Heat Fab Inc. (800-772-0739), Protech Systems Inc. (800-766-3473), Z-Flex (800-654-5600) or American Metal Products (800-423-4270). Pipe joints must be positively sealed. Follow the vent manufacturer's installation instructions carefully.

Direct Vent - Vertical

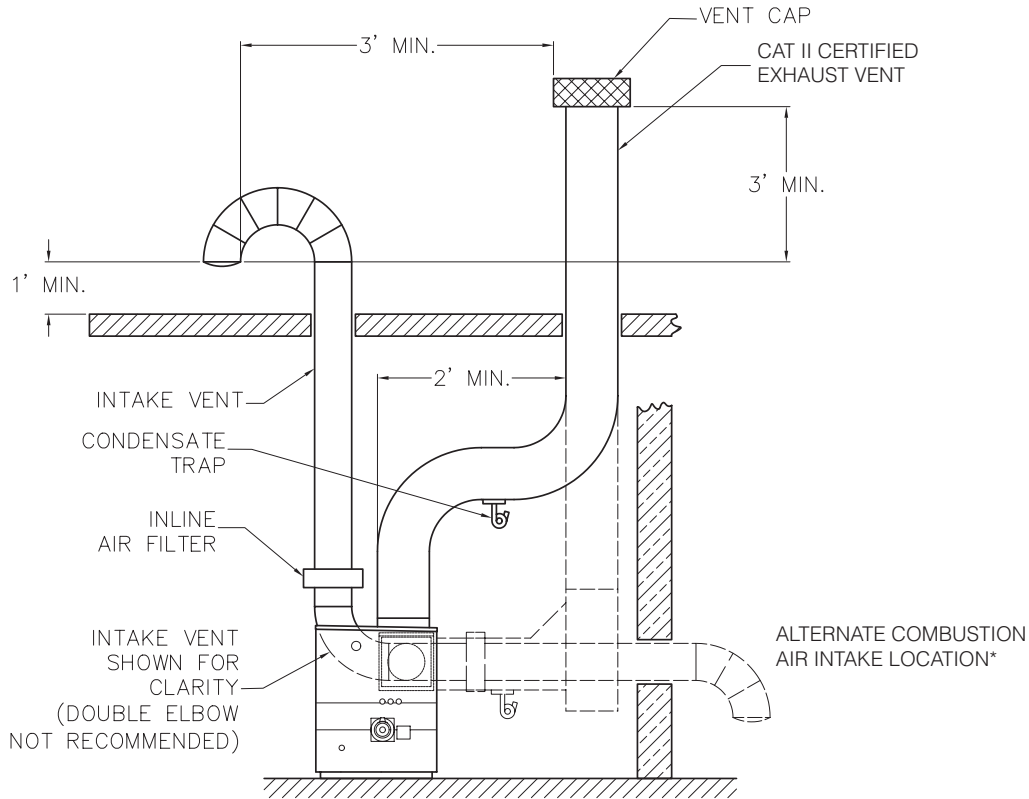

Note: When vertical height exceeds 25 ft, consult factory prior to installation.

*Requires optional vent tee if vented horizontally out back of heater.

Fig. 46: Direct Vent - Vertical

Model	Certified Venting Material	Vent Size	Vertical Venting Height*		Combustion Air Intake Pipe Material	Air Inlet Max. Length**	
			Min.	Max.		10"	12"
992BE	Category II or IV	10"	5'	25'	Galvanized Steel, PVC, ABS, CPVC	75'	100'
1262BE							
1532BE							
1802BE		12"					
2002BE		14"				40'	75'
2072BE							
2342BE		16"					

* Vent lengths are based on a lateral length of 2 ft. Refer to the latest edition of the NFGC for further details. When vertical height exceeds 25 ft, consult factory prior to installation.

** Subtract 10 ft per elbow. Max. 3 elbows.

Maximum combustion air duct length terminated at 100 equivalent ft.

Table U: Category II or IV Vertical Venting

Wiring Diagram—Models 992B-1262B

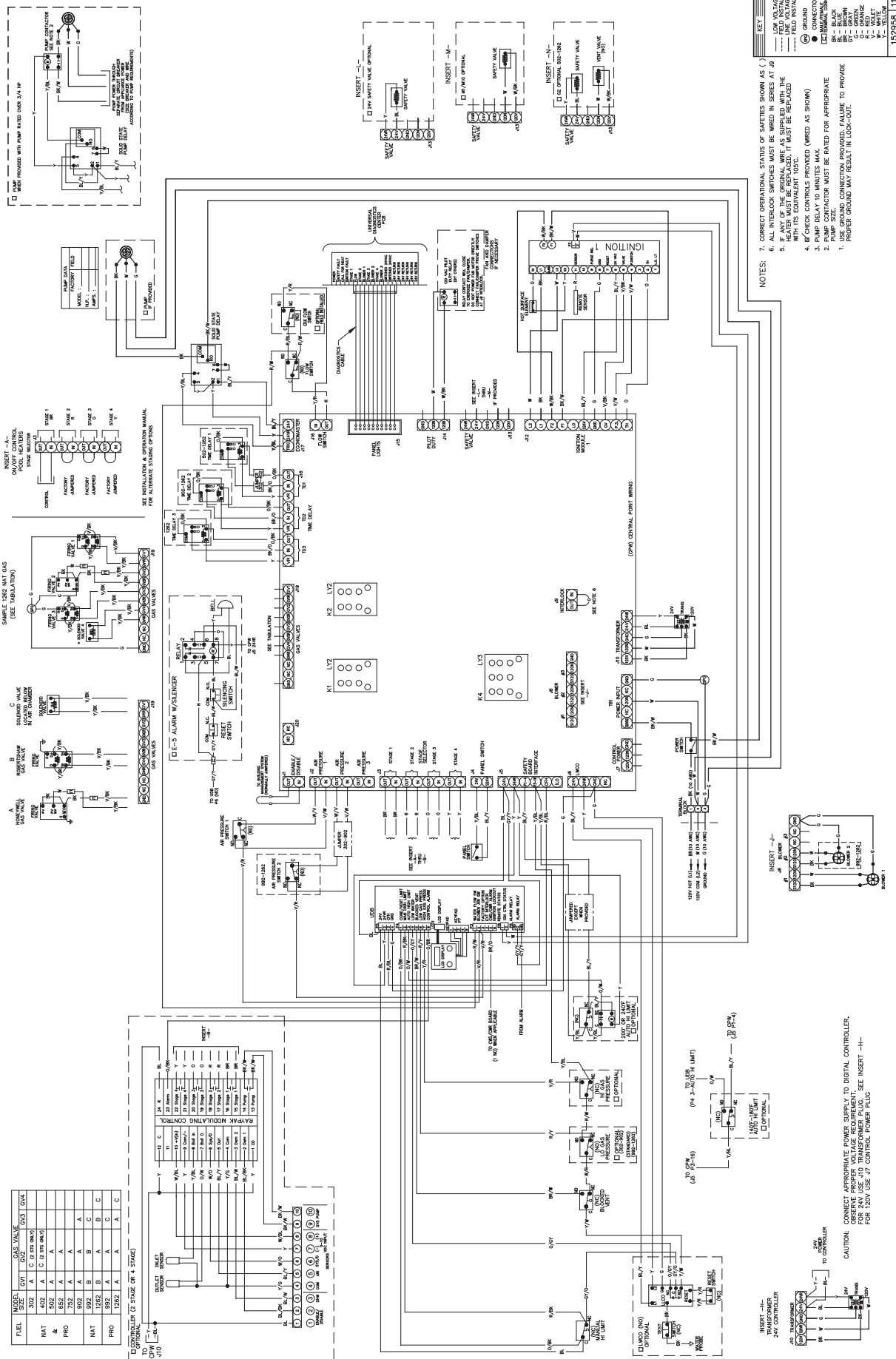

Wiring Diagram—Models 1532B-2342B

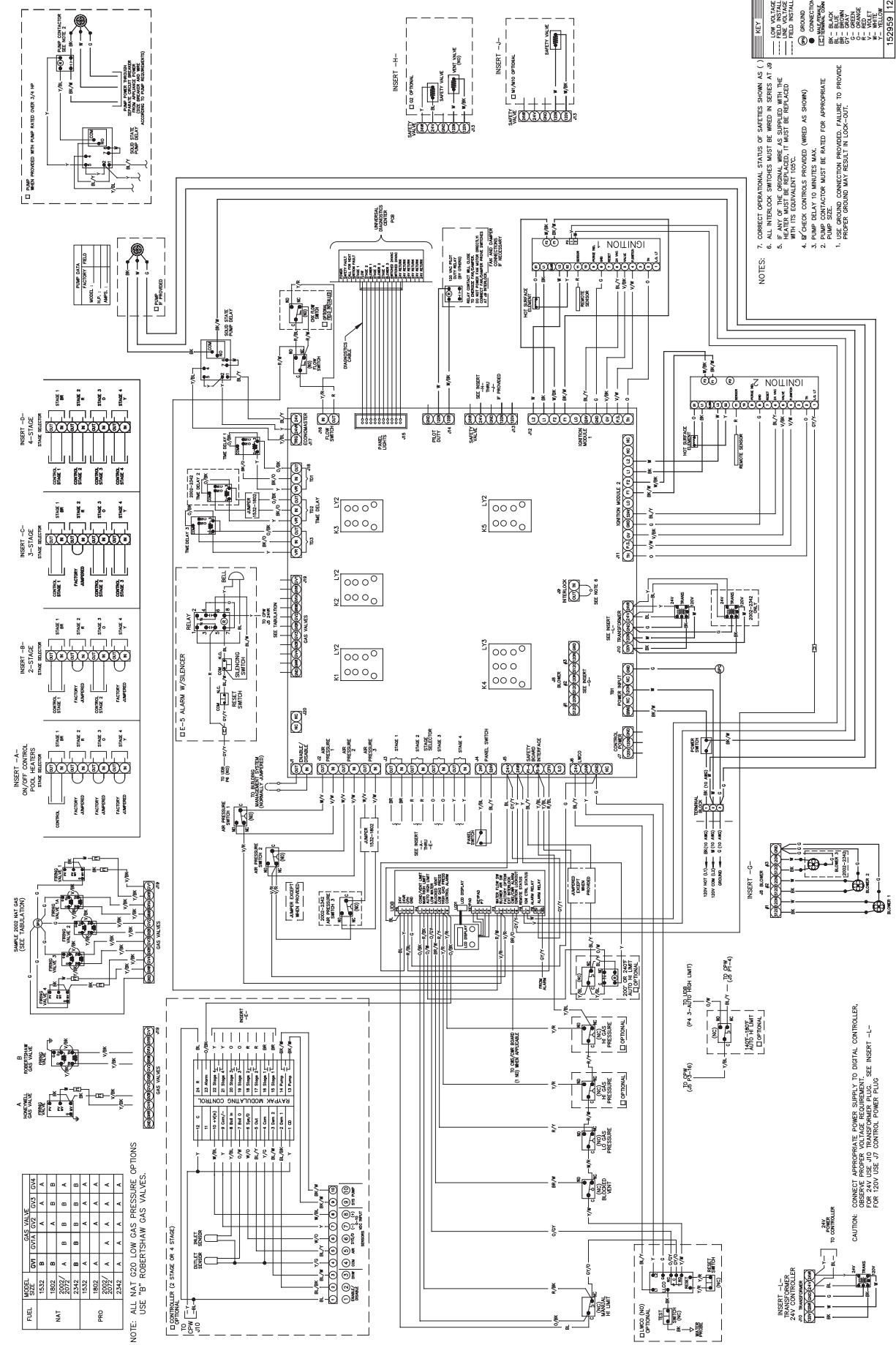

NOTE: ALL NAT G20 LOW GAS PRESSURE OPTIONS USE "B" ROBERTSHAW GAS VALVES.

FUEL	MODEL	GAS VALVE	CONTROL	CONTROL	CONTROL	CONTROL
NAT	1532	B	A	A	A	A
	2032	B	A	B	B	A
	2342	B	B	B	B	A
PRO	1532	B	B	A	A	A
	2032	A	A	A	A	A
	2342	A	A	A	A	A

TO CONTROLLER (2 STAGE OR 4 STAGE)
 TO GAS VALVES

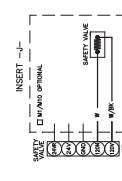
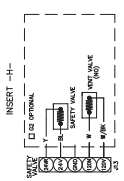
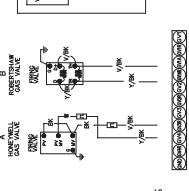
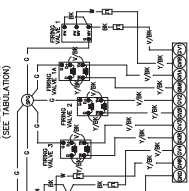
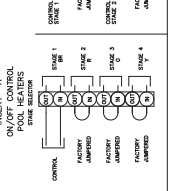
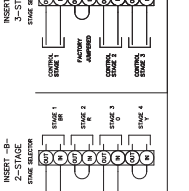
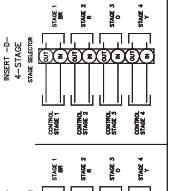
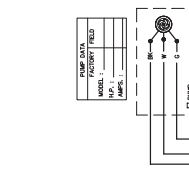
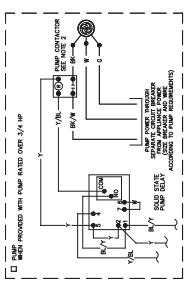

- NOTES:**
- CORRECT OPERATIONAL STATUS OF SAFETIES SHOWN AS ()
 - ALL INTERLOCK SWITCHES MUST BE WIRED IN SERIES AT JO
 - IF ANY OF THE ORIGINAL WIRE AS SUPPLIED WITH THE WATER MUST BE REPLACED, IT MUST BE REPLACED
 - IF CHECK CONTROLS PROVIDED (WIRED AS SHOWN)
 - PUMP CONTACTOR MUST BE RATED FOR APPROPRIATE
 - USE GROUND CONNECTION PROVIDED, FAILURE TO PROVIDE PROPER GROUND MAY RESULT IN LOCK-OUT.
- KEY**
- RELAY INSTALL
 - RELAY INSTALL
 - CONNECTION
 - TERMINATION
 - - BLACK
 - - BROWN
 - - GRAY
 - - ORANGE
 - - WHITE
 - - YELLOW
 - - BLUE
- 152959 1/2

CAUTION: TRANSFER APPROPRIATE POWER SUPPLY TO DIGITAL CONTROLLER, FOR 24V USE J10 TRANSFORMER PLUG. SEE INSERT -L- FOR 120V USE OF CONTROL POWER PLUG

START-UP

Pre Start-up

Filling System (Heating Boilers)

Fill system with water. Purge all air from the system. Lower system pressure. Open valves for normal system operation, and fill system through feed pressure. Manually open air vent on the compression tank until water appears, then close vent.

Air Purge (Domestic Hot Water Heaters)

Purge all air from system before lighting heater. This can be normally accomplished by opening a downstream valve.

Venting System Inspection

1. Check all vent pipe connections and flue pipe material.
2. Make sure vent terminations are installed per code and are clear of all debris or blockage.

For Your Safety

WARNING: If you do not follow these instructions exactly, a fire or explosion may result causing property damage, personal injury or loss of life.

This appliance has a hot surface igniter. It is equipped with an ignition device which automatically lights the burners. Do not try to light the burners by hand.

BEFORE OPERATING, smell all around the appliance area for gas. Be sure to smell near the floor because some gas is heavier than air and will settle on the floor.

WHAT TO DO IF YOU SMELL GAS:

- Do not try to light any appliance.
- Do not touch any electrical switch; do not use any telephone in your building.
- Immediately call your gas supplier from a neighbor's telephone. Follow the gas supplier's instructions.

- If you cannot reach your gas supplier, call the fire department.
- Use only your hand to push in or turn the gas control knob. Never use tools. If the knob will not turn by hand, do not try to repair it, call a qualified service technician. Forced or attempted repair may result in a fire or explosion.
- Do not use this appliance if any part has been under water, immediately call a qualified service technician to inspect the appliance and to replace any part of the control system and any gas control which has been under water.
- Check around unit for debris and remove combustible products, i.e. gasoline, etc.

Pre Start-up Check

1. Verify heater is filled with water.
2. Check system piping for leaks. If found, repair immediately.
3. Vent air from system. Air in system can interfere with water circulation.
4. Purge air from gas line up to heater.

Initial Start-up

Tools Needed

- (1) 12-0-12, 24" scale U-tube manometer
- (4) 6-0-6, 12" scale U-tube manometers (minimum)
- (1) Screwdriver
- (1) Multi-meter
- (1) 3/16" Allen wrench

NOTE: Digital manometers are not recommended.

Preparation

WARNING: Do not turn on gas at this time.

Check Power Supply

With multi-meter at incoming power, check voltage between:

Hot - Common (≈ 120 VAC)

Hot - Ground (≈ 120 VAC)

Common - Ground (< 1 VAC)

WARNING: If Common - Ground is > 1 VAC, STOP: Contact electrician to correct ground failure. Failure to do this may burn out 120V-24V transformer, or may cause other safety control damage or failure.

Attach Manometers to Measure Pressures

1. Turn off main gas valve.
2. Attach 24" scale manometer to the first main gas shut-off valve pressure tapping.
3. Attach (1) 12" scale manometer to the outlet side of the second main gas shut-off valve pressure tapping.
4. Attach (1) 12" scale manometer near the fan-proving switch. Pull black cap from air pressure switch tee and connect the manometer. NOTE: Retain caps for reinstallation later.

Check Gas Supply Pressure

1. Slowly turn on main gas shut-off valve.
2. Read the gas supply pressure from the manometer; minimum supply pressure for natural gas is 5.0 in. WC, recommended supply is 7.0 in. WC, minimum supply pressure for propane gas is 11.0 in. WC (dynamic readings, all stages firing).
3. If the pressure is > 14.0 in. WC, turn off the valve.
4. Check if the service regulator is installed and/or adjust the service regulator.

Start-Up

Blower Adjustment

1. Turn off power.
2. Unplug cap at pressure switches and connect manometer(s) to the tee.
3. Close all manual firing valves.
4. Turn power on.
5. Check manometers attached to fan pressure switch. The reading should be $1.4 \pm .1$ in. WC for propane gas and natural gas. If not, adjust the air shutter on the blowers to attain the correct value.
6. Turn power off.
7. Reconnect this cap.

Main Burner Adjustment

1. Turn off unit.
2. Open manual firing valves.
3. Turn on the unit, wait 15 seconds, and the igniter should glow. Look into sight glass located at each end of the heater to check igniter operation. Gas valves should open in 45-60 seconds.
4. If burner does not light on first trial. It will retry, up to three times.
5. Main burner ignition: Check manifold gas pressure at gas valve outlet pressure tap. This should read 3.5 ± 0.1 in. WC for natural gas and 10.5 ± 0.1 in. WC for propane gas.
6. If the pressure reading differs by more than ± 0.1 in. WC, remove screw cover from the gas pressure regulator and adjust main burner manifold pressure. Replace the screw cover. Repeat steps 2 to 5 on other valves as necessary.

CAUTION: Special manifold and air settings may be required. Verify rating plate and blower housing.

Safety Inspection

1. Check all thermostats and high limit settings.
2. During the following safety checks leave manometers hooked up, check and record.
3. If other gas-fired appliances in the room are on the same gas main, check all pressures on the Hi Delta with all other equipment running.
4. Check thermostats for ON-OFF operation.
5. Check high limits for ON-OFF operation.
6. While in operation, check flow switch operation.
7. Check the low gas pressure switch. (For proper adjustment, use the attached manometers, if available, to set pressure. The scales on the switch are approximate only.) Low gas pressure switch must be set at 5.0 in. WC for natural gas and 10.0 in. WC for propane gas.
8. Make sure that the high gas pressure switch (optional) is set to 1.0 in. WC above manifold pressure.

Follow-Up

Safety checks must be recorded as performed.

Turn heater on. After main burner ignition:

1. Check manometer for proper reading.
2. Cycle heater several times and re-check readings.
3. Remove all manometers and replace caps and screws.
4. Replace all gas pressure caps.
5. Check for gas leaks one more time.

Ignition Test

The Hi Delta heaters, depending on their size, have two to five burner sections. Each burner section is supplied gas by gas valves incorporated into a single valve body. A maximum of three burner sections may be controlled by a single hot surface ignition system. The middle of the three burner sections is ignited directly with a hot surface ignition system.

The burner section that is ignited directly by the hot surface ignition system serves as a supervised pilot to light the burner sections on either side of it. The burner sections on either side of the supervised section (pilot) are electrically interlocked with the supervised ignition system so as they are not energized unless flame is proven on the center section which is acting as a pilot to light the right and left-hand sections.

The ignition test is conducted as follows:

1. Turn off manual valves on non-supervised burner sections.
2. Turn on electrical power and adjust thermostat to call for heat.
3. Wait for completion of ignition sequence to light burner section being utilized as a pilot for those turned off in step 1 above.
4. Gradually reduce manifold pressure (flame) on supervised burner section by slowly closing manual gas valve. Watch for shut-down due to loss of supervised flame signal as pressure is being reduced. Flame signal should be lost before manifold pressure goes below 2.0 in. WC for natural gas and 6.0 in. WC for propane gas.

Leak Test Procedure: Dual-Seat Gas Valves

Proper leak testing requires three pressure test points in the gas train.

Test point A is upstream of the automatic gas valve. On the first automatic valve, this is a bleedle valve. On the other valves, this is a plugged port. The bleedle valve on the first valve may be used for all the other valves as well.

Test point B is a bleedle valve located between the two automatic gas valve seats.

Test point C is located downstream of both automatic gas valve seats and upstream of the manual valve. On the manual valve, this is a bleedle valve. Identical readings will be found at the plugged port labeled as Alternate C.

Refer to Fig. 47. The numbers on the diagram refer to the steps below:

These tests are to be conducted with the electrical power to the heater turned off.

1. Manually close the downstream leak test valve.
2. Open test point A and connect a manometer to it. Verify that there is gas pressure and that it is within the proper range (NOTE: must not exceed 14.0 in. WC).
3. Open test point B and connect a rubber tube to it. Connect the other end of the tube to a manometer and look for a build-up of pressure. Increasing pressure indicates a leaking gas valve.
4. Next, close the upstream manual gas valve and remove the manometer from test point A and from test point B. Connect a rubber tube from test point A to test point B and open the upstream manual gas valve. Make sure that test points A & B have been opened so as to allow gas to flow. This will bring pressure to the second valve seat.
5. Open test point C and connect a second rubber tube to it. Connect the other end of the tube to a manometer and look for a build-up of pressure. Increasing pressure indicates a leaking gas valve.
6. Remove rubber tube and manometers. Close each test point valve as the tubes are removed.
7. Connect a manometer to each test point (one at a time) and look for a build-up of pressure. If a build-up of pressure is detected, check each test point valve to see if it is tightly closed. If leak persists, replace test point valve(s).
8. After no leakage has been verified at all valve seats and test valves, open downstream leak tests valve and restore electrical power to heater.

This completes leak testing for a single Hi Delta manifold riser. Repeat steps 1-8 for each riser.

Post Start-Up Check

Check off steps as completed:

1. Verify that the heater and heat distribution units or storage tank are filled with water.
2. Confirm that the automatic air vent (if used) was opened two full turns during the venting procedure.
3. Verify that air has been purged from the system.
4. Verify that air has been purged from the gas piping, and that the piping has been checked for leaks.
5. Confirm that the proper start-up procedures were followed.
6. Inspect burner to verify flame.
7. Test safety controls: If heater is equipped with a low water cut-off or additional safety controls, test for operation as outlined by manufacturer. Burner should be operating and should go off when controls are tested. When safety devices are restored, burners should re-ignite after pre-purge time delay.
8. Test limit control: While burner is operating, move indicator on high limit control below actual water temperature. Burner should go off while blower and circulator continue to operate. Raise setting on limit control above water temperature and burner should re-ignite after pre-purge time delay.
9. Test ignition system safety device:
 - a. Turn on manual gas valve. Turn power on.
 - b. Set thermostat to call for heat.
 - c. When the heater is in operation, pull cap off of tee in air switch hose. The burner should go off immediately.
 - d. Wait 5 minutes.
 - e. Reattach cap on tee. Burner should re-ignite after pre-purge time delay.

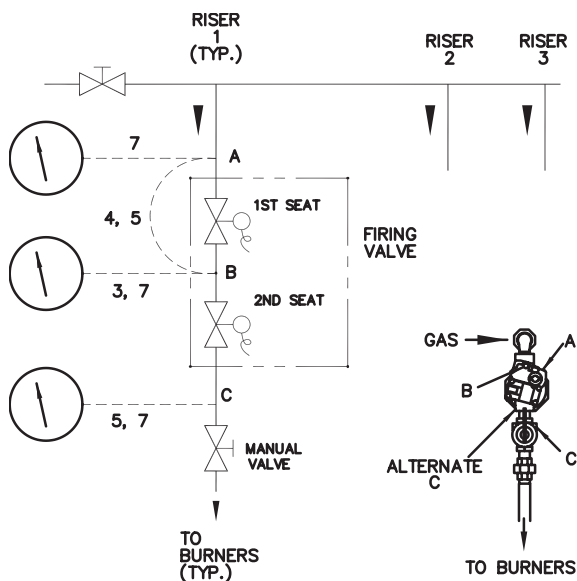

Fig. 47: Leak Test

-
- To restart system, follow lighting instructions in the Operation section.
 - Check to see that the high limit control is set above the design temperature requirements of the system.

For multiple zones: Check to make sure the flow is adjusted as required in each zone.

- Check that the heater is cycled with the thermostat. Raise to the highest setting and verify that the heater goes through the normal start-up cycle. Reduce to the lowest setting and verify that the heater goes off.
- Observe several operating cycles for proper operation.
- Set the room thermostat or tankstat to desired temperature.
- Review all instructions shipped with this heater with owner or maintenance person, return to envelope and give to owner or place the instructions inside front panel on heater.

OPERATION

Lighting Instructions

- Before lighting, make sure you have read all of the safety information in this manual.
- Set the thermostat to the lowest setting.
- Turn off all electrical power to the appliance.
- This appliance is equipped with an ignition device which automatically lights the burner. Do not try to light the burner by hand.
- Remove upper front panel.
- Turn on main manual gas valve.
- Wait 5 minutes to clear out any gas. Then smell for gas, especially near the floor. If you then smell gas, **STOP!** Follow the steps in the safety information on the front cover of this manual. If you do not smell gas, go to next step.
- Turn on all electrical power to the appliance.

- Set thermostat to desired setting. The appliance will operate. The igniter will glow after the pre-purge time delay (15 seconds). After igniter reaches temperature (45 seconds) the main valve will open. System will try for ignition three times. If flame is not sensed, lockout will commence.
- If the appliance will not operate, follow the instructions "To Turn Off Gas To Appliance," and call your service technician or gas supplier.
- Replace access panel.
- If heater fails to start, verify the following:
 - There are no loose connections or that the service switch is off.
 - High temperature limit switch is set above water temperature.
 - Thermostat is set above room temperature.
 - Gas is on at the meter and the heater.
 - Incoming gas pressure to the gas valve is NOT less than 5.0 in. WC for natural gas, 11.0 in. WC for propane gas.

To Turn Off Gas To Appliance

- Set the thermostat to lowest setting.
- Turn off all electrical power to the appliance if service is to be performed.
- Remove upper front panels.
- Turn off main manual gas valve.
- Replace access panel.

TROUBLESHOOTING

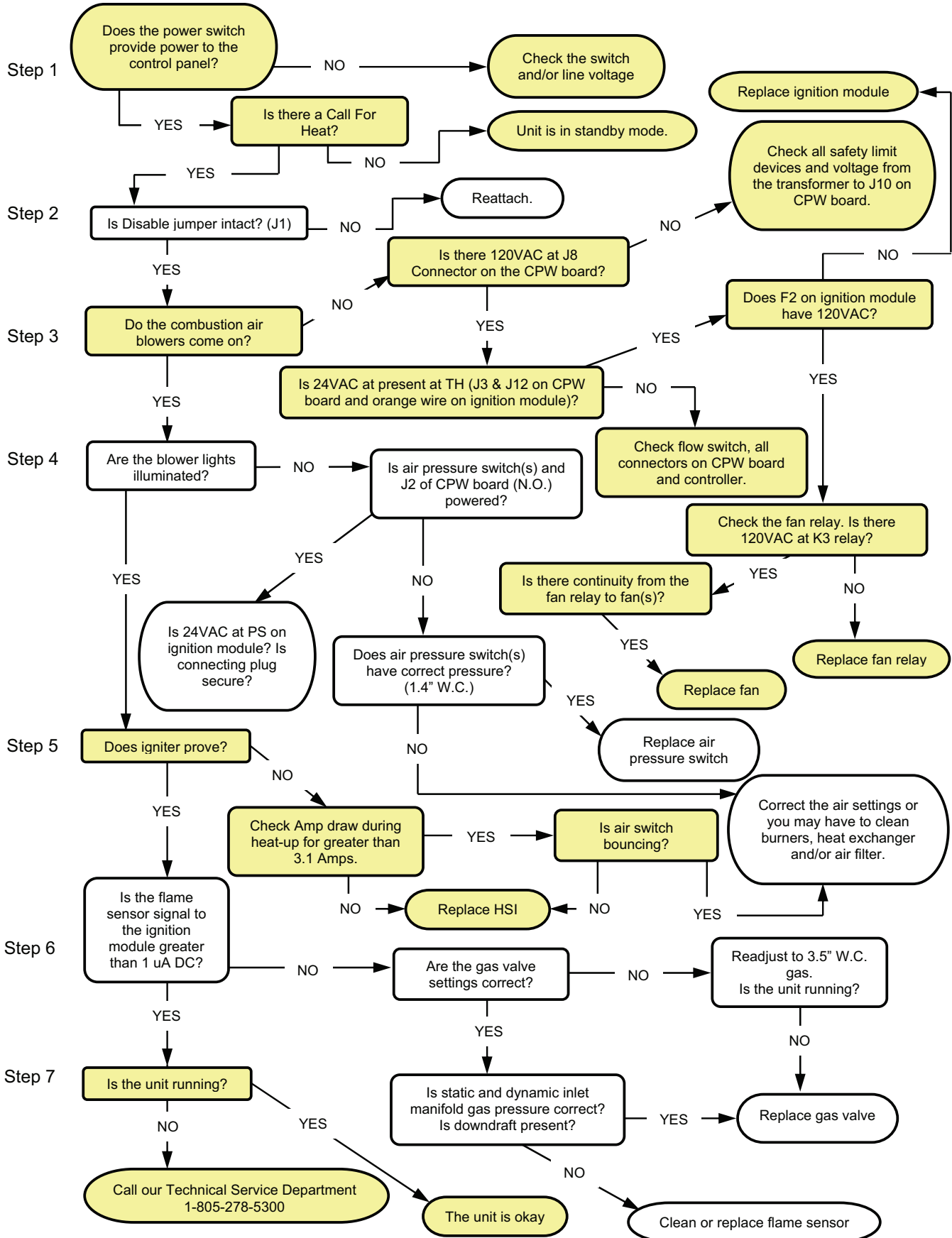

MAINTENANCE

Suggested Minimum Maintenance Schedule

Regular service by a qualified service agency and maintenance must be performed to ensure maximum operating efficiency.

Maintenance as outlined below may be performed by the owner.

Daily

1. Check that the area where the heater is installed is free from combustible materials, gasoline, and other flammable vapors and liquids.
2. Check for and remove any obstruction to the flow of combustion or ventilation air to heater.

Monthly

1. Check for piping leaks around circulators, mixing valves, relief valves, and other fittings. If found, repair at once. DO NOT use petroleum-based stop-leak compounds.
2. Visually inspect burner flame.
3. Visually inspect venting system for proper function, deterioration or leakage.
4. Check air vents for leakage.

Yearly (Beginning Of Each Heating Season)

Schedule annual service call by qualified service agency.

1. Visually check top of vent for soot. Call service person to clean. Some sediment at bottom of vent is normal.
2. Visually inspect venting system for proper function, deterioration or leakage.
3. Check that area is free from combustible materials, gasoline, and other flammable vapors and liquids.

4. Check for and remove any obstruction to the flow of combustion or ventilation air to heater.
5. Follow pre-start-up check in the Start-up section.
6. Visually inspect burner flame. It should be light blue. Remove and visually inspect hot surface igniter and sensor for damage, cracking or debris build-up.
7. Check operation of safety devices. Refer to manufacturers' instructions.
8. Follow oil-lubricating instructions on circulator if required. Over-oiling will damage circulator. Water-lubricated circulators do not need oiling.
9. To avoid potential of severe burn, DO NOT REST HANDS ON OR GRASP PIPES. Use a light touch; return piping will heat up quickly.
10. Check blower and blower motor.
11. Check for piping leaks around circulators, relief valves and other fittings. Repair, if found. DO NOT use petroleum-based stop-leak.
12. Clean air filter.

Periodically

1. Check relief valve. Refer to manufacturer's instructions on valve.
2. Test low water cut-off, if used. Refer to manufacturer's instructions.
3. Clean screen and air filter in intake.

Preventive Maintenance Schedule

The following is required procedure in CSD-1 states and good practice for all Hi Delta installations.

Daily

1. Check gauges, monitors and indicators.
2. Check instrument and equipment settings. (See "Post Start-Up Check" on page 54.)
3. Check burner flame. (Should see light blue flame).

Weekly

For low-pressure heaters, test low-water cut-off device. (With at least one stage of the appliance on, depress the low water cut-off test button, appliance should shut-off and ignition fault light should come on. Depress reset button to reset).

Monthly

1. Check flue, vent, stack, or outlet dampers.
2. Test fan air pressure. (See “Blower Adjustment” on page 52.)
3. Test high and low gas pressure interlocks (if equipped). (See “Safety Inspection” on page 53.)

Semi-Annually

1. Recalibrate all indicating and recording gauges.
2. Check flame failure detection system components. (See “Pilot Turn-Down Test Procedure,” page 53.)
3. Check firing rate control by checking the manifold pressure. (See “Main Burner Adjustment” on page 52.)
4. Check piping and wiring of all interlocks and shut-off valves.

Annually

1. Test flame failure detection system and pilot turn-down. (See “Pilot Turn-Down Test Procedure,” page 53.)
2. Test high limit and operating temperature. (See “Post Start-Up Check,” page 54.)
3. Check flame sensors.
4. Conduct a combustion test at full fire. Carbon dioxide should be $8.2\% \pm 0.5\%$ at full fire for natural gas, and $9.4\% \pm 0.5\%$ for propane gas; Carbon monoxide should be < 150 ppm).
5. Check coils for 60 cycle hum or buzz. Check for leaks at all valve fittings using a soapy water solution. Test other operating parts of all safety shut-off and control valves and increase or decrease settings (depending on the type of control) until the safety circuit opens. Reset to original setting after each device is tested.

6. Perform leakage test on gas valves. (See Fig. 47.)
7. Test air switch in accordance with manufacturer’s instructions. (Turn panel switch to the “On” position until blower is proven, then turn the switch to “Off”.
8. Inspect and clean burners as necessary.

As Required

1. Recondition or replace low water cut-off device (if equipped).
2. Check drip leg and gas strainers.
3. Perform flame failure detection and pilot turn-down tests.
4. Check igniter. Amp draw should be 3.2 amps or greater during ignition.
5. Check flame signal strength. (Flame signal should be greater than 1 microamp).
6. Test safety/safety relief valves in accordance with ASME Heater and Pressure Vessel Code Sections VI and VII.

APPENDIX

Inside Air Contamination

All heaters experience some condensation during start-up. The condensate from flue gas is acidic. Combustion air can be contaminated by certain vapors in the air which raise the acidity of the condensate. Higher acidity levels attack many materials including stainless steel, which is commonly used in high efficiency systems. The heater can be supplied with corrosion-resistant, non-metallic intake air vent material. You may, however, choose to use outside combustion air for one or more of these reasons:

1. Installation is in an area containing contaminants listed below which will induce acidic condensation.
2. You want to reduce infiltration into your building through openings around windows and doors.
3. You are using stainless steel vent pipe, which is more corrosion-resistant than standard metallic vent pipe. In extremely contaminated areas, this may also experience deterioration.

Products causing contaminated combustion air:

- spray cans containing chloro/fluorocarbons
- permanent wave solutions
- chlorinated waxes/cleaners
- chlorine-based swimming pool chemicals
- calcium chloride used for thawing
- sodium chloride used for water softening
- refrigerant leaks
- paint or varnish removers
- hydrochloric acid/muriatic acid
- cements and glues
- antistatic fabric softeners used in clothes dryers
- chloride-type bleaches, detergents, and cleaning solvents found in household laundry rooms
- adhesives used to fasten building products
- similar products

Areas where contaminated combustion air commonly exists:

- dry cleaning/laundry areas
- metal fabrication plants
- beauty shops
- refrigeration repair shops
- photo processing plants
- auto body shops
- plastic manufacturing plants

- furniture refinishing areas and establishments
- new building construction
- remodeling areas
- open pit skimmers

Check for areas and products listed above before installing heater. If found:

- remove products permanently, OR
- install TruSeal direct vent



**LIMITED PARTS WARRANTY
HI DELTA – TYPES H AND WH
MODELS 992B–2342B**

SCOPE

Raypak, Inc. ("Raypak") warrants to the original owner that all parts of this heater which are actually manufactured by Raypak will be free from failure under normal use and service for the specified warranty periods and subject to the conditions set forth in this Warranty. Labor charges and other costs for parts removal or reinstallation, shipping and transportation are not covered by this Warranty but are the owner's responsibility.

HEAT EXCHANGER WARRANTY

Domestic Hot Water

Five (5) years from date of heater installation. Includes copper heat exchanger with bronze and cast iron waterways.

Ten (10) years from date of heater installation. Includes only cupro-nickel heat exchanger with bronze or cast iron waterways.

Space Heating (Closed Loop System)

Ten (10) years from date of heater installation. Includes both cupro-nickel and copper heat exchanger with bronze or cast iron waterways.

Thermal Shock Warranty

Twenty (20) years from date of heater installation against "Thermal Shock" (excluded, however, if caused by heater operation at large changes exceeding 150°F between the water temperature at intake and heater temperature, or operating at heater temperatures exceeding 230°F).

ANY OTHER PART MANUFACTURED BY RAYPAK

One (1) year warranty from date of heater installation, or eighteen (18) months from date of factory shipment based on Raypak's records, whichever comes first.

SATISFACTORY PROOF OF INSTALLATION DATE, SUCH AS INSTALLER INVOICE, IS REQUIRED. THIS WARRANTY WILL BE VOID IF THE HEATER RATING PLATE IS ALTERED OR REMOVED.

ADDITIONAL WARRANTY EXCLUSIONS

This warranty does not cover failures or malfunctions resulting from:

1. Failure to properly install, operate or maintain the heater in accordance with our printed instructions provided;
2. Abuse, alteration, accident, fire, flood and the like;
3. Sediment or lime build-up, freezing, or other conditions causing inadequate water circulation;
4. High velocity flow exceeding heater design rates;
5. Failure of connected systems devices, such as pump or controller;
6. Use of non-factory authorized accessories or other components in conjunction with the heater system;
7. Failing to eliminate air from, or replenish water in, the connected water system;
8. Chemical contamination of combustion air or use of chemical additives to water.

PARTS REPLACEMENT

Under this Warranty, Raypak will furnish a replacement for any failed part. The failed part must first be returned to Raypak if requested, with transportation charges prepaid, and all applicable warranty conditions found satisfied. The replacement part will be warranted for only the unexpired portion of the original warranty. Raypak makes no warranty whatsoever on parts not manufactured by it, but Raypak will apply any such warranty as may be provided to it by the parts manufacturer.

TO MAKE WARRANTY CLAIM

Promptly notify the original installer, supplying the model and serial numbers of the unit, date of installation and description of the problem. The installer must then notify his Raypak distributor for instructions regarding the claim. If either is not available, contact Service Manager, Raypak, Inc., 2151 Eastman Avenue, Oxnard, CA 93030 or call (805) 278-5300. In all cases proper authorization must first be received from Raypak before replacement of any part.

EXCLUSIVE WARRANTY - LIMITATION OF LIABILITY

This is the only warranty given by Raypak. No one is authorized to make any other warranties on Raypak's behalf. THIS WARRANTY IN LIEU OF ALL OTHER WARRANTIES, EXPRESS OR IMPLIED, INCLUDING BUT NOT LIMITED TO IMPLIED WARRANTIES OF MERCHANTABILITY AND FITNESS FOR A PARTICULAR PURPOSE. RAYPAK'S SOLE LIABILITY AND THE SOLE REMEDY AGAINST RAYPAK WITH RESPECT TO DEFECTIVE PARTS SHALL BE AS PROVIDED IN THIS WARRANTY. IT IS AGREED THAT RAYPAK SHALL HAVE NO LIABILITY, WHETHER UNDER THIS WARRANTY, OR IN CONTRACT, TORT, NEGLIGENCE OR OTHERWISE, FOR ANY SPECIAL, CONSEQUENTIAL, OR INCIDENTAL DAMAGE, INCLUDING DAMAGE FROM WATER LEAKAGE. Some states do not allow limitations on how long an implied warranty lasts, or for the exclusion of incidental or consequential damages. So the above limitation or exclusion may not apply to you.

This Limited Warranty gives you specific legal rights. You may also have other rights which may vary from state to state. We suggest that you complete the information below and retain this certificate in the event warranty service is needed. Reasonable proof of the effective date of the warranty (date of installation) must be presented, otherwise, the effective date will be based on the rate of manufacture plus thirty (30) days.

Original Owner

Model Number

Mailing Address

Serial Number

Date of Installation

City State Zip Code

Installation Site

Daytime Telephone Number

Contractor/Installer

RAYPAK, INC • 2151 Eastman Avenue • Oxnard, CA 93030-9786 • (805) 278-5300 • Fax (800) 872-9725 • www.raypak.com



**LIMITED PARTS WARRANTY
HI DELTA – TYPE P AND WHP
MODELS 992B–2342B**

SCOPE

Raypak, Inc. (“Raypak”) warrants to the original owner that all parts of this heater which are actually manufactured by Raypak will be free from failure under normal use and service for the specified warranty periods and subject to the conditions set forth in this Warranty. Labor charges and other costs for parts removal or reinstallation, shipping and transportation are not covered by this Warranty but are the owner’s responsibility.

HEAT EXCHANGER WARRANTY

Five (5) years from date of heater installation. Includes cupro-nickel heat exchanger with bronze waterways.

Thermal Shock Warranty

Twenty (20) years from date of heater installation against “Thermal Shock” (excluded, however, if caused by heater operation at large changes exceeding 150°F between the water temperature at intake and heater temperature, or operating at heater temperatures exceeding 230°F).

ANY OTHER PART MANUFACTURED BY RAYPAK

One (1) Year warranty from date of heater installation, or eighteen (18) months from date of factory shipment based on Raypak’s records, whichever comes first.

SATISFACTORY PROOF OF INSTALLATION DATE, SUCH AS INSTALLER INVOICE, IS REQUIRED. THIS WARRANTY WILL BE VOID IF THE HEATER RATING PLATE IS ALTERED OR REMOVED.

ADDITIONAL WARRANTY EXCLUSIONS

This warranty does not cover failures or malfunctions resulting from:

1. Failure to properly install, operate or maintain the heater in accordance with our printed instructions provided;
2. Abuse, alteration, accident, fire, flood and the like;
3. Sediment or lime build-up, freezing, or other conditions causing inadequate water circulation;
4. High velocity flow exceeding heater design rates;
5. Failure of connected systems devices, such as pump or controller;
6. Use of non-factory authorized accessories or other components in conjunction with the heater system;
7. Chemical contamination of combustion air or use of chemical additives to water.
8. Misuse or neglect, including but not limited to freeze-ups, operating the heater with cabinet door off, having flow restrictions or obstructions between the heater outlet and pool/spa or not maintaining proper chemical balance (pH level must be between 7.2 and 7.8 and total alkalinity between 100 and 150 PPM. Total Dissolved Solids (TDS) must be no greater than 1500 PPM, or 4500 PPM in salt water chlorinated pools).

PARTS REPLACEMENT

Under this Warranty, Raypak will furnish a replacement for any failed part. The failed part must first be returned to Raypak if requested, with transportation charges prepaid, and all applicable warranty conditions found satisfied. The replacement part will be warranted for only the unexpired portion of the original warranty. Raypak makes no warranty whatsoever on parts not manufactured by it, but Raypak will apply any such warranty as may be provided to it by the parts manufacturer.

TO MAKE WARRANTY CLAIM

Promptly notify the original installer, supplying the model and serial numbers of the unit, date of installation and description of the problem. The installer must then notify his Raypak distributor for instructions regarding the claim. If either is not available, contact Service Manager, Raypak, Inc., 2151 Eastman Avenue, Oxnard, CA 93030 or call (805) 278-5300. In all cases proper authorization must first be received from Raypak before replacement of any part.

EXCLUSIVE WARRANTY - LIMITATION OF LIABILITY

This is the only warranty given by Raypak. No one is authorized to make any other warranties on Raypak’s behalf. THIS WARRANTY IN LIEU OF ALL OTHER WARRANTIES, EXPRESS OR IMPLIED, INCLUDING BUT NOT LIMITED TO IMPLIED WARRANTIES OF MERCHANTABILITY AND FITNESS FOR A PARTICULAR PURPOSE, RAYPAK’S SOLE LIABILITY AND THE SOLE REMEDY AGAINST RAYPAK WITH RESPECT TO DEFECTIVE PARTS SHALL BE AS PROVIDED IN THIS WARRANTY. IT IS AGREED THAT RAYPAK SHALL HAVE NO LIABILITY, WHETHER UNDER THIS WARRANTY, OR IN CONTRACT, TORT, NEGLIGENCE OR OTHERWISE, FOR ANY SPECIAL, CONSEQUENTIAL, OR INCIDENTAL DAMAGE, INCLUDING DAMAGE FROM WATER LEAKAGE. Some states do not allow limitations on how long an implied warranty lasts, or for the exclusion of incidental or consequential damages. So the above limitation or exclusion may not apply to you.

This Limited Warranty gives you specific legal rights. You may also have other rights which may vary from state to state. We suggest that you complete the information below and retain this certificate in the event warranty service is needed. Reasonable proof of the effective date of the warranty (date of installation) must be presented, otherwise, the effective date will be based on the rate of manufacture plus thirty (30) days.

Original Owner

Mailing Address

City State Zip Code

Daytime Telephone Number

Model Number

Serial Number

Date of Installation

Installation Site

Contractor/Installer

RAYPAK, INC • 2151 Eastman Avenue • Oxnard, CA 93030-9786 • (805) 278-5300 • Fax (800) 872-9725 • www.raypak.com

Important Instructions for the Commonwealth of Massachusetts

The Commonwealth of Massachusetts requires compliance with regulation 248 CMR 4.00 and 5.00 for installation of through – the – wall vented gas appliances as follows:

(a) For all side wall horizontally vented gas fueled equipment installed in every dwelling, building or structure used in whole or in part for residential purposes, including those owned or operated by the Commonwealth and where the side wall exhaust vent termination is less than seven (7) feet above finished grade in the area of the venting, including but not limited to decks and porches, the following requirements shall be satisfied:

1. **INSTALLATION OF CARBON MONOXIDE DETECTORS.** At the time of installation of the side wall horizontal vented gas fueled equipment, the installing plumber or gasfitter shall observe that a hard wired carbon monoxide detector with an alarm and battery back-up is installed on the floor level where the gas equipment is to be installed. In addition, the installing plumber or gasfitter shall observe that a battery operated or hard wired carbon monoxide detector with an alarm is installed on each additional level of the dwelling, building or structure served by the side wall horizontal vented gas fueled equipment. It shall be the responsibility of the property owner to secure the services of qualified licensed professionals for the installation of hard wired carbon monoxide detectors

a. In the event that the side wall horizontally vented gas fueled equipment is installed in a crawl space or an attic, the hard wired carbon monoxide detector with alarm and battery back-up may be installed on the next adjacent floor level.

b. In the event that the requirements of this subdivision can not be met at the time of completion of installation, the owner shall have a period of thirty (30) days to comply with the above requirements; provided, however, that during said thirty (30) day period, a battery operated carbon monoxide detector with an alarm shall be installed.

2. **APPROVED CARBON MONOXIDE DETECTORS.** Each carbon monoxide detector as required in accordance with the above provisions shall comply with NFPA 720 and be ANSI/UL 2034 listed and IAS certified.

3. **SIGNAGE.** A metal or plastic identification plate shall be permanently mounted to the exterior of the building at a minimum height of eight (8) feet above grade directly in line with the exhaust vent terminal for the horizontally vented gas fueled heating appliance or equipment. The sign shall read, in print size no less than one-half (1/2) inch in size, "GAS VENT DIRECTLY BELOW. KEEP CLEAR OF ALL OBSTRUCTIONS".

4. **INSPECTION.** The state or local gas inspector of the side wall horizontally vented gas fueled equipment shall not approve the installation unless, upon inspection, the inspector observes carbon monoxide detectors and signage installed in accordance with the provisions of 248 CMR 5.08(2)(a)1 through 4.

(b) **EXEMPTIONS:** The following equipment is exempt from 248 CMR 5.08(2)(a)1 through 4:

1. The equipment listed in Chapter 10 entitled "Equipment Not Required To Be Vented" in the most current edition of NFPA 54 as adopted by the Board; and

2. Product Approved side wall horizontally vented gas fueled equipment installed in a room or structure separate from the dwelling, building or structure used in whole or in part for residential purposes.

(c) **MANUFACTURER REQUIREMENTS - GAS EQUIPMENT VENTING SYSTEM PROVIDED.** When the manufacturer of Product Approved side wall horizontally vented gas equipment provides a venting system design or venting system components with the equipment, the instructions provided by the manufacturer for installation of the equipment and the venting system shall include:

1. Detailed instructions for the installation of the venting system design or the venting system components; and

2. A complete parts list for the venting system design or venting system.

(d) **MANUFACTURER REQUIREMENTS - GAS EQUIPMENT VENTING SYSTEM NOT PROVIDED.** When the manufacturer of a Product Approved side wall horizontally vented gas fueled equipment does not provide the parts for venting the flue gases, but identifies "special venting systems", the following requirements shall be satisfied by the manufacturer:

1. The referenced "special venting system" instructions shall be included with the appliance or equipment installation instructions; and

2. The "special venting systems" shall be Product Approved by the Board, and the instructions for that system shall include a parts list and detailed installation instructions.

(e) A copy of all installation instructions for all Product Approved side wall horizontally vented gas fueled equipment, all venting instructions, all parts lists for venting instructions, and/or all venting design instructions shall remain with the appliance or equipment at the completion of the installation.

GAS PRESSURE SUPERVISION

The Commonwealth of Massachusetts requires listed high and low gas pressure switches (manual reset) for any model with a maximum firing input greater than 1,000,000 Btu/Hr in accordance with 248 CMR 7.04(11)(d).

A gas pressure regulator (field supplied) is required in the gas train ahead of the heater, for heaters having input rates greater than 1,000,000 Btu/Hr, in accordance with 248 CMR 7.04 Figure 3B requirements.

START-UP CHECKLIST FOR FAN-ASSISTED RAYPAK PRODUCTS

This start-up checklist is to be completely filled out by the service technician starting up the Raypak Boiler or Heater for the first time. All information may be used for warranty purposes and to ensure that the installation is correct. Additionally this form will be used to record all equipment operation functions and required settings.

GAS SUPPLY DATA

Regulator Model & Size _____ / _____ CFH
 Gas Line Size (in room) _____ In. NPT
 Length of Gas Line _____ Eq Ft
 Low Gas Pressure Setting _____ In. WC
 High Gas Pressure Setting _____ In. WC
 Gas Shut-Off Valve Type _____
 (Ball, Lube cock)
 Sediment Trap _____ Y/N
 Port _____ Std _____ Full

VISUAL INSPECTION OF COMPONENTS

Verify inspection was done and condition of components are in good working order with a "yes"

Wiring Harness _____ Y/N
 Burner/s (flame) _____ Y/N
 Refractory (visual) _____ Y/N
 Remote flame sense _____ Y/N
 Covers in place for outdoor _____ Y/N

VENTING

Vent Size: _____ Stack Height: _____
 Category: _____ sketch vent on reverse side ***
 Vent Material: _____
 Vent Termination Type: _____
 Combustion Air Openings: Low _____ in2
 Ventilation air High _____ in2

EMISSIONS SETTINGS AND TEST INFORMATION (AT FULL FIRE)

Blower Pressure Setting _____ In. WC
 Supply Gas Pressure _____ In. WC
 Verify stable pressure static & dynamic condition
 Pilot Gas Pressure _____ In. WC
 Manifold Gas Pressure _____ In. WC

The following measurements must be obtained with a Combustion Analyzer.

NOX _____ PPM
 Free Oxygen _____ %
 CO _____ PPM
 CO2 _____ %

Model Number: _____

*** Note: draw venting with details, such as extractors, barometric dampers, blast dampers or draft inducers

Job Name _____

Address _____

Physical Location of Boiler: Indoors _____; Outdoors _____; Ground Level _____; Roof _____; Below Grade _____

Mechanical Contractor / Installer _____

Date and Time of Start-up _____ Print Name and Signature of Start-up Technician _____

CLEARANCES

Front Clearance _____ In.
 Right Side Clearance _____ In.
 Left Side Clearance _____ In.
 Rear Clearance _____ In.
 Overhead Clearance _____ In.

ELECTRICAL

Voltage Supply (VAC) No Load _____ Load _____
 Voltage -24 VAC _____ VAC
 Voltage Com to Ground _____ VAC
 Hot Surface Igniter _____ Ohms
 Auto High Limit Setting _____ deg F
 Manual Reset High Limit Setting _____ deg F
 Operating Control Setting _____ deg F

Sketch plumbing on reverse side

WATER SUPPLY

Flow Rate in GPM or Delta T _____ If Avail
Measure flow rate at full fire
 Pump Economaster setting _____ Minutes
 Low Water Cutoff _____ Test
 Number of Tanks and Size Qty _____ Gallons
 Plumbing Size _____
 Pump Size: _____ (boiler) Pump HP: _____
 Impeller trim _____ Pump Model _____
 Louvers _____ Screens _____

Nominal Factory Recommended Settings

See manual or card tag
 See manual or card tag
 See manual or card tag
 See manual or card tag

Information must be faxed to: (805) 278-5496 in order to ensure warranty consideration Attn: Service Manager



www.raypak.com

Raypak, Inc., 2151 Eastman Avenue, Oxnard, CA 93030 (805) 278-5300 Fax (805) 278-5468
Litho in U.S.A.

INSTALLATION & OPERATING INSTRUCTIONS

Cold Water Start & Cold Water Run

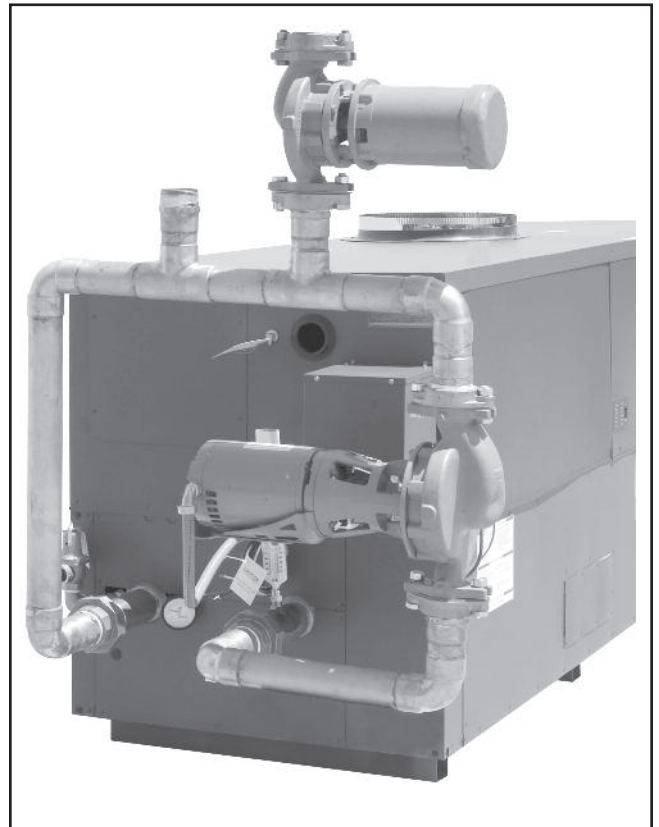
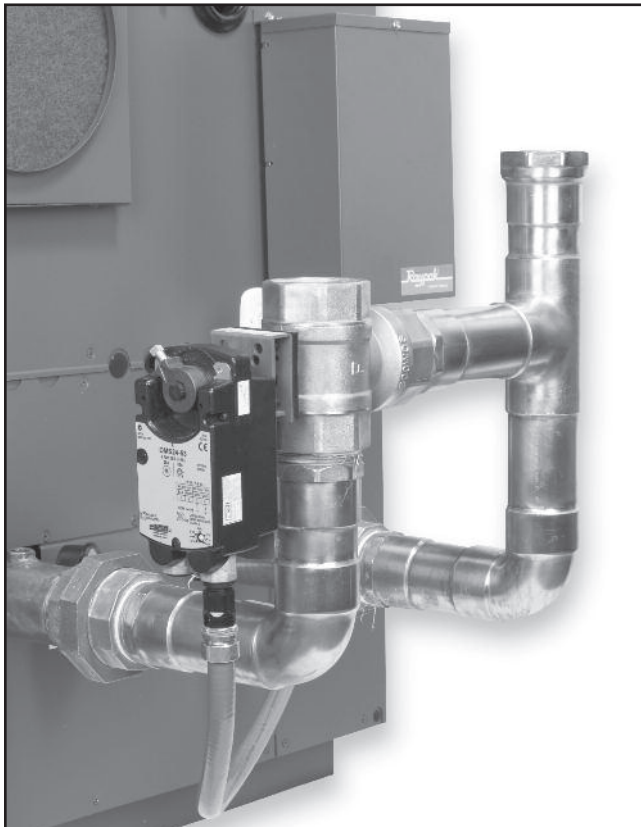

For Hi Delta, MVB & Raytherm Heaters & Boilers

This manual should be maintained in legible condition and kept adjacent to the heater or in another safe place for future reference.

Raypak®
A Rheem® Company

Rev. 10 reflects the following:

Changes to: None

Additions: None

Deletions: Illustrated Parts List (was on previous pages 34-39)

CONTENTS

WARNINGS	4	Connecting Cold Water Start to Multi-Heater Interlock Box	18
GENERAL SAFETY	5	Connecting Heater to Cold Water Start Multi-Heater Interlock	18
Time/Temperature Relationships in Scalds	5	Actuator to Valve Orientation	19
COLD WATER START	6	Three-Way Valve Ball Orientation	19
Installation	6	Valve Installation	19
Check Power Source	6	4 Inch Valve Orientation	20
Mounting the Control Box	6	Connecting the Actuator	20
Installing the Temperature Sensor	7	Typical Cold Water Start Multiple Boiler Piping	21
Connecting the Valve Assembly	7	Wiring Diagram	22
Connecting Power to the Controller	8	COLD WATER RUN	23
Connecting Boiler to Cold Water Start Operation	8	Purpose	23
Operation	8	Typical Cold Water Run Applications	23
Cold Start Sequence of Operation	9	CWR vs. CWS	23
Troubleshooting	10	Installation	23
Mounting the Actuator to the Valve	11	Installation Codes	23
Mounting Brackets	11	Mounting the Control Box	23
Locating the Rotation Stop	11	Injector & Heater Pump Comparison	24
Drive Linkage	12	Check the Power Source	25
Verifying Ball Position	12	Injector Pump Wiring	25
Actuator to Valve Orientation	12	Injection Pump Cover Installation	27
Installing the Three-Way Valve	13	Typical Cold Water Run Piping - Heating Applications	29
High Pressure Tab	13	Typical Cold Water Run Piping - Pool Applications	29
Actuator	13	Operation	30
Cold Water Start Troubleshooting Guide	14	Cold Run Sequence of Operation	30
Typical Cold Water Start Piping	15	Cold Water Run Troubleshooting Guide	31
Wiring Diagram	16	Wiring Diagrams	32
Heater Interface Wiring	17	REPLACEMENT PARTS	34
CWS—MULTIPLE BOILER	18		
Materials Included	18		
Installation	18		
Mounting the Control Boxes	18		
Installing the Temperature Sensor	18		
Installing the Three-Way Valve	18		
Connecting Power to the Controller	18		

WARNINGS

Pay Attention to These Terms

DANGER:	Indicates the presence of immediate hazards which will cause severe personal injury, death or substantial property damage if ignored.
WARNING:	Indicates the presence of hazards or unsafe practices which could cause severe personal injury, death or substantial property damage if ignored.
CAUTION:	Indicates the presence of hazards or unsafe practices which could cause minor personal injury or product or property damage if ignored.
NOTE:	Indicates special instructions on installation, operation, or maintenance which are important but not related to personal injury hazards.

NOTE: Minimum 18 AWG, 105°C, stranded wire must be used for all low voltage (less than 30 volts) external connections to the unit. Solid conductors should not be used because they can cause excessive tension on contact points. Install conduit as appropriate. All high voltage wires must be the same size (105°C, stranded wire) as the ones on the unit or larger.

NOTE: Piping diagrams in this manual are not intended to replace an engineered piping system.

NOTE: Consult the factory for units with a 30 pound pressure relief valve (PRV).

GENERAL SAFETY

To meet commercial hot water use needs, the high limit safety control on this water heater is adjustable up to 210°F. However, water temperatures over 125°F can cause instant severe burns or death from scalds. When supplying general purpose hot water, the recommended initial setting for the temperature control is 125°F.

Safety and energy conservation are factors to be considered when setting the water temperature on the thermostat. The most energy-efficient operation will result when the temperature setting is the lowest that satisfies the needs of the application.

Water temperature over 125°F can cause instant severe burns or death from scalds. Children, disabled and elderly are at highest risk of being scalded.

- Feel water before bathing or showering.
- Temperature limiting valves are available.

NOTE: When this water heater is supplying general purpose hot water for use by individuals, a thermostatically controlled mixing valve for reducing point of use water temperature is recommended to reduce the risk of scald injury. Contact a licensed plumber or the local plumbing authority for further information.

Maximum water temperatures occur just after the heater's burner(s) have shut off. To determine the water temperature being delivered, turn on a hot water faucet and place a thermometer in the hot water stream and read the thermometer.

DANGER

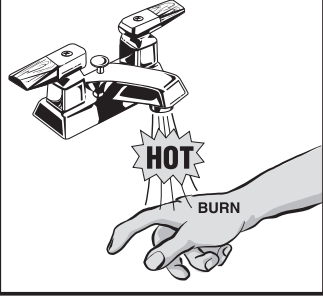

Water temperature over 125°F can cause instant severe burns or death from scalds.

Children, disabled, and elderly are at highest risk of being scalded.

See instruction manual before setting temperature at water heater.

Feel water before bathing or showering.

Temperature limiting valves are available, see manual.

Time/Temperature Relationships in Scalds

The following chart details the relationship of water temperature and time with regard to scald injury and may be used as a guide in determining the safest water temperature for your applications.

Water Temp.	Time to Produce Serious Burn
120°F	More than 5 minutes
125°F	1-1/2 to 2 minutes
130°F	About 30 seconds
135°F	About 10 seconds
140°F	Less than 5 seconds
145°F	Less than 3 seconds
150°F	About 1-1/2 seconds
155°F	About 1 second

Table courtesy of The Shriners Burn Institute

Table A: Time to Produce Serious Burn

COLD WATER START

Before beginning the installation, it's important to first inspect the system and determine what materials you will need. Some parts are included with the controller while others you will need to provide.

- 1 Control Box
 - 1 Temperature Sensor
 - 1 Valve assembly with actuator (Shipped separately)
- Wiring and mounting hardware (Provided by installer)

NOTE: After testing at the factory it may be prudent to ship the piping assembly disassembled and attached to the heater pallet. This is done to avoid shipping damage and it must be reassembled on the jobsite. Use Fig. 1 to assist in reassembling the piping.

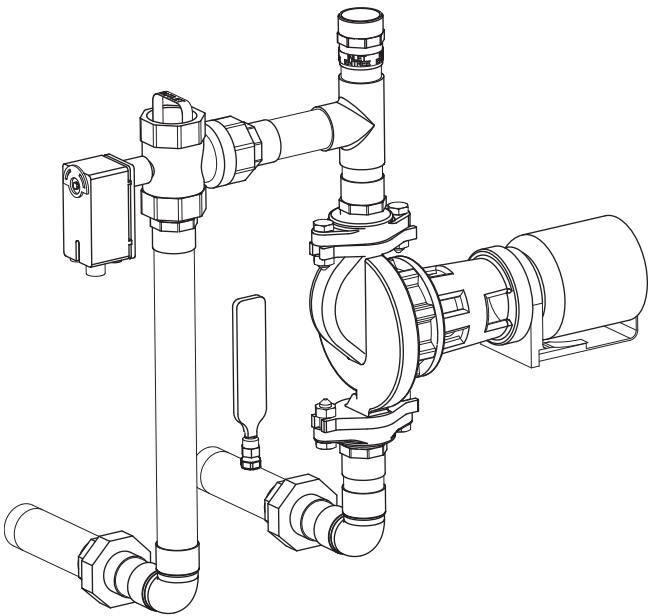

Fig. 1: Cold Water Start Assembly

Installation

Check the Power Source

CAUTION: Do not use for swimming pool applications

WARNING: Using a multi-meter, check the following voltages at the breaker panel prior to connecting any equipment. Make sure proper polarity is followed and house ground is proven.

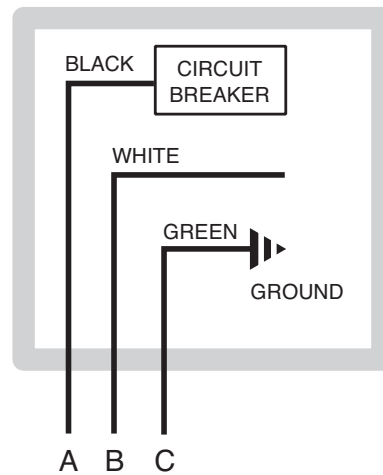

Fig. 2: Wiring Connections

Check the power source:

- AC = 108 VAC Minimum, 132 VAC MAX
- AB = 108 VAC Minimum, 132 VAC MAX
- BC = <1 VAC Maximum

Mounting the Control Box

The control box should be mounted on the side of the heater to which the system piping and valve assembly are to be attached as shown in Figs. 4–8. The controller should be mounted so as to provide maximum support by using the mounting holes provided on the base of the controller to the side center brace on the heater. On MVB and Hi Delta models, locating dimples are provided for ease of drilling the mounting holes. You will need to drill mounting holes through the heater side panel for the routing of wiring and the sensor.

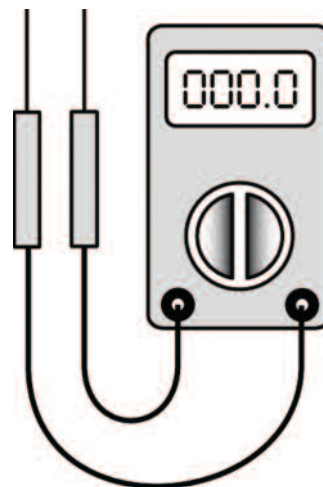

Fig. 3: Multi-meter

Installing the Temperature Sensor

Avoid routing wiring on or near other electrical wires, conduit, motors, spark igniters or other sources of high intermittent voltage or current. The sensor should be placed in the dry well on the inlet header, or as indicated in the piping for multiple heaters, as shown on page 21. Ensure it is installed using thermal paste (field supplied) and that it is held firmly at the bottom of the well.

Connecting the Valve Assembly

Connect the valve assembly into the bypass piping. The branch (port B) is connected to the crossover pipe (bypass between inlet and outlet). The actuator tail stock should be oriented to point down. Refer to the Actuator to Valve Orientation section.

Route wiring from the valve to the controller thru one of the bottom panel conduit knockouts to TB2. Refer to the wiring diagram provided on the inside of the controller cover assembly.

CAUTION: Miswiring the actuator may cause unwarrantable damage. Verify the wire colors against the actuator make and model.

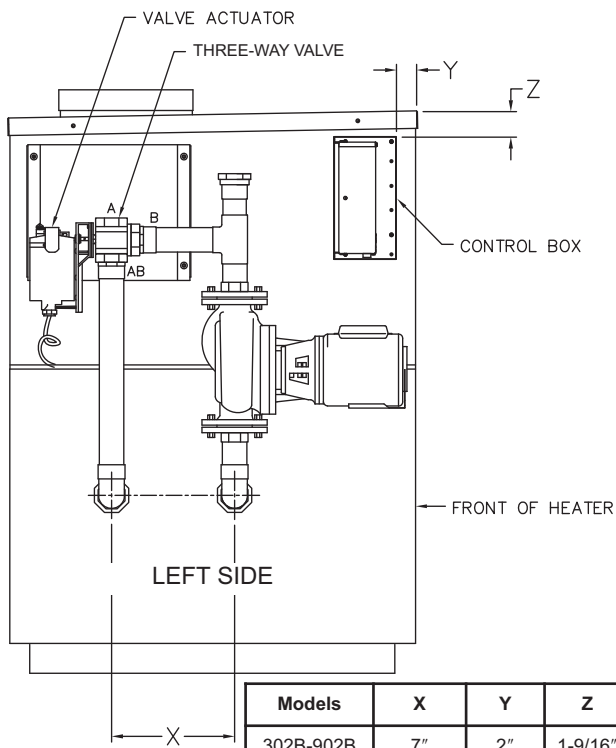

Fig. 4: Component Locations—Hi Delta

NOTE: Four knockouts are located on the bottom of the control for ease of installation.

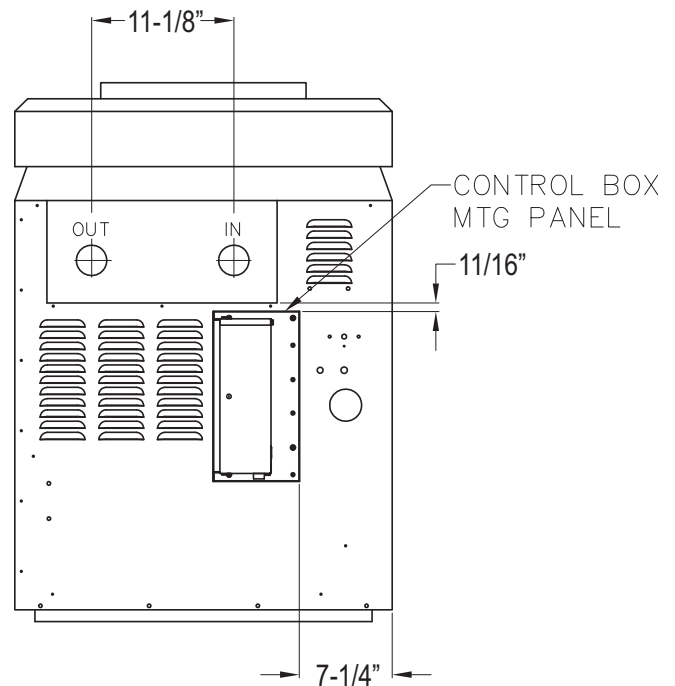

Fig. 5: Component Locations—Raytherm Models 514-824

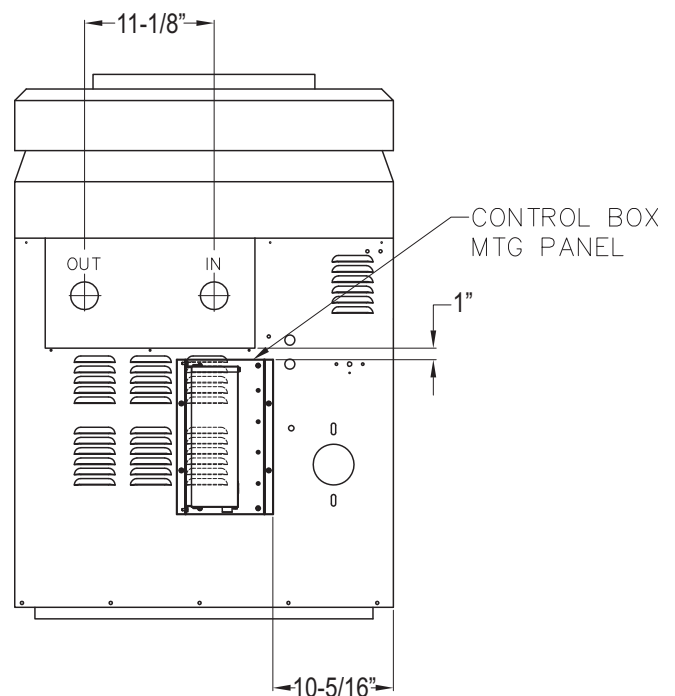

Fig. 6: Component Locations—Raytherm Models 926-1826

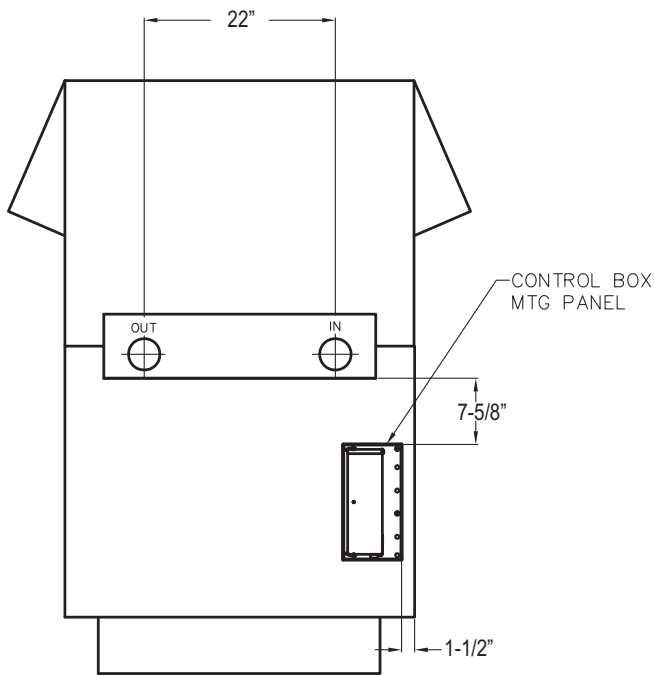

Fig. 7: Component Locations—Raytherm Models 2100–4001

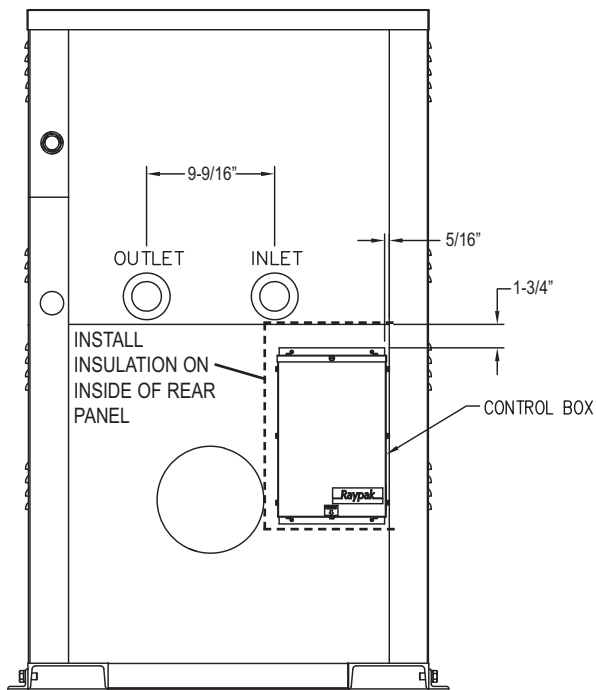
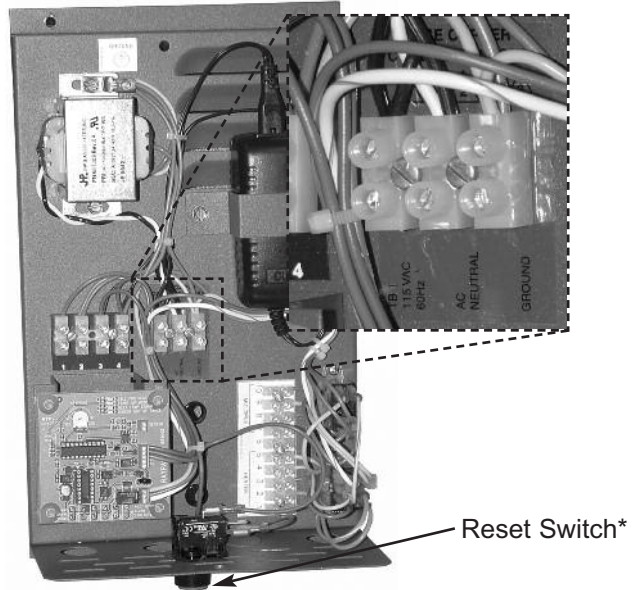

Fig. 8: Component Locations—MVB

CAUTION: Install the foil-faced insulation on the inside of the rear panel of MVB heaters as indicated in Fig. 8. Use spray adhesive or high temp foil tape to attach the insulation. Ensure that the foil faces the heat exchanger assembly. Failure to install this insulation as directed can cause overheating of the components and may void the warranty on the control.



*The reset switch may be located on the front control panel on some MVB models.

Fig. 9: Location of TB1 in Control Box

Connecting Power to the Controller

Connect power from the 120 VAC power input of the heater to the controller power inputs Terminal Block (TB1). This is accomplished by connecting wiring from the control box to the heater 120 VAC power input connections. Refer to the heater wiring diagrams.

Connecting Boiler to Cold Water Start

The installer must provide five 18AWG stranded wires between the heater and the controller terminal block. Wiring is to be run in separate conduit from line voltage to ensure proper operation. Refer to the diagrams on page 17 for connection points depending on the Raypak product being used.

Operation

Verify the following upon a CALL FOR HEAT signal from the heater:

1. CALL FOR HEAT: LED on PCB illuminates GREEN.
2. START UP MODE: LED on PCB illuminates YELLOW. It should go out in less than 7 minutes, as the boiler inlet temperature approaches the setpoint temperature.
3. The "ACTUATOR" should be in the fully open position or move to the fully open position if not already there. (Actuator and ball rotated to the at-rest CCW position).

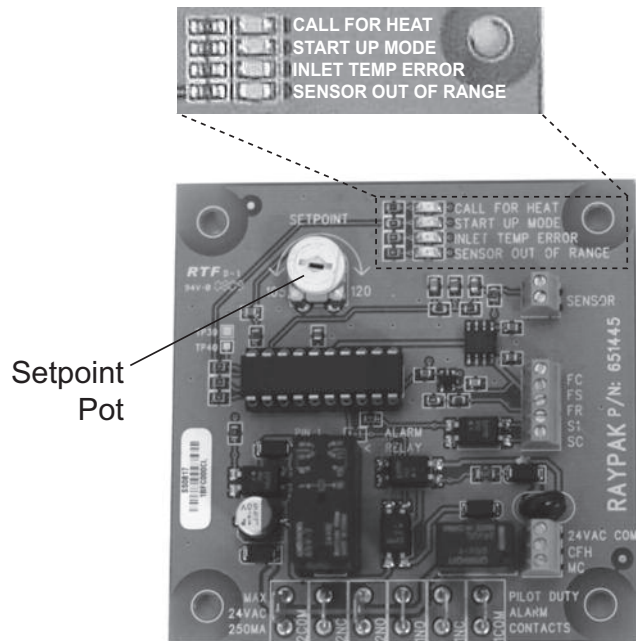

Fig. 10: Control PCB

- If the control is operating properly, the “START UP MODE” LED should go out in less than 7 minutes. At this point, the inlet water temperature should be stable at a temperature between 105°F and 120°F corresponding to the Setpoint Pot setting on the PCB. The actuator should have stopped moving.

NOTE: The minimum inlet water temperature to the heater to prevent condensate is 105°F on heaters with an efficiency of 85% or less, and 120°F on 87% efficiency heaters. Ensure that during operation the Setpoint Pot is adjusted properly.

NOTE: If a “DIP” switch is provided on the control PCB, verify that the switch settings are: 1 = OFF, 2 = ON, 3 = OFF.

Cold Start Sequence of Operation

- 120VAC to heater sends 120VAC to Cold Start control on terminal block 1.
- 120/24VAC transformer and 120VAC-12VDC converter are powered.
- 120/24VAC transformer outputs 24VAC to pin 2 of terminal block 2
- 24VAC leaves pin 2 of terminal block 2 and goes to the modulating three-way valve on the 20-30VAC lead, and to the NO contacts of the SPST relay located in the cold start control panel.

- 120VAC-12VDC converter outputs 12VDC to the common terminal of the reset switch, located on the bottom of the cold start control panel.
- The 12VDC signal crosses over the reset switch and goes to Terminal FS on the cold start circuit board.
- Cold start control is now in standby until a Call for Heat occurs at heater.
- The heater outputs 24VAC to terminal 4 of terminal block 3 located in Cold Start controller to indicate a CFH from the heater.
- Terminal 4 of TB 3 sends 24VAC to the coil of the SPST relay located in the cold start control panel.
- The SPST relay coil is energized and closes the contacts allowing 24VAC to energize the CFH terminal on the cold start circuit board.
 - A two second delay occurs from the CFH signal to the output of power from terminal MC of the cold start circuit board.
- 24 VAC is sent from terminal 2 of terminal block 3 to the NO contacts of the DPST relay located in the cold start control panel.
- After the two second delay on the cold start circuit board, pin MC outputs a 24 VAC signal to the coil of the DPST relay located in the cold start control panel.
- The DPST relay coil energizes and closes the NO contacts.
- Once the NO contacts of the DPST close, the heater 24 VAC is sent back to the heater to complete the circuit (pin 3 of terminal block 3) and the interlock circuit (pin 1 & 2 of terminal block 3) allowing the heater to fire.
- Pin FR on the TVC board outputs 10VDC to the modulating three-way valve actuator to drive it fully open for two minutes waiting for the heater to reach full fire.
- After the two-minute delay the 10VDC output signal from pin FR reduces to approximately 8VDC.
- The output signal continues to vary depending on the heater inlet temperature.

NOTE: The heater will lockout and shut down if the setpoint on the inlet temperature is not achieved within seven minutes from a call for heat.

The DIP switches on the three-way valve actuator must be set as indicated in the Fig. 11 below:

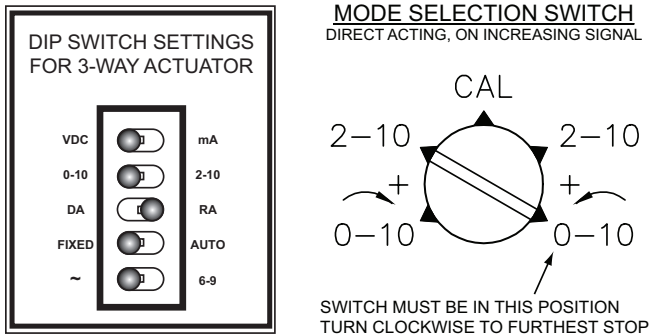

Fig. 11: Set Dip Switch Settings — Delta Actuator

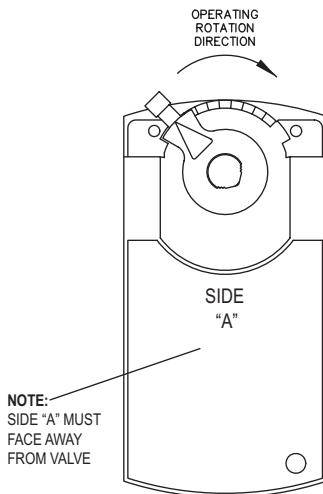

Fig. 12: Delta Actuator — Actuator Shown in Full System Flow Position

CAUTION: Delta actuator requires the use of the factory-supplied weatherproof cover for outdoor installations.

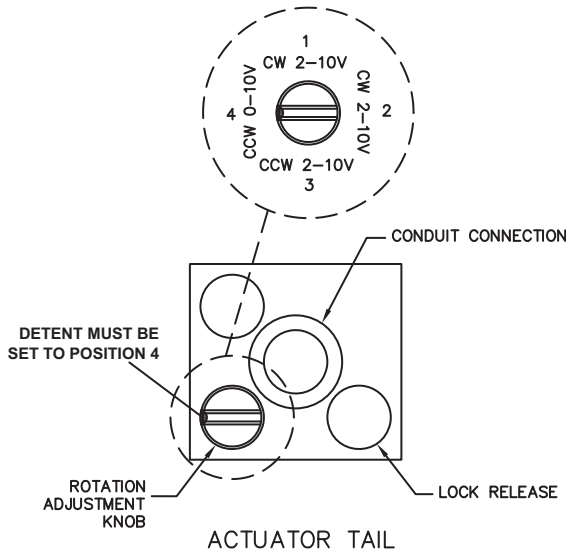

Fig. 13: Elodrive Actuator — Rotation Knob Setting
Set adjustment knob to Position 4

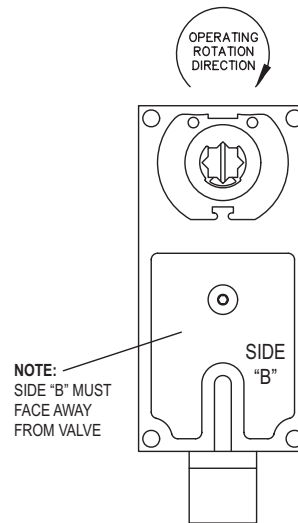

Fig. 14: Elodrive Actuator — Actuator Shown in Full System Flow Position

NOTE: The Elodrive actuator is NEMA 4 rated. No outdoor cover is required.

Troubleshooting

Check your power source using a Volt-Ohm meter; check the following voltages at TB1 terminal block:

TB1-1 to TB1-2 = 108 VAC Minimum, 132 VAC Maximum

TB1-1 to TB1-3 = 108 VAC Minimum, 132 VAC Maximum

TB1-2 to TB1-3 = Must be less than .6 VAC

IF CALL FOR HEAT LED does not illuminate when the heater has a CFH signal, check for 24VAC between pins 4 and 5 of TB3 on the cold start control. If voltage is present, check wiring using the wiring diagram. If voltage is not present, the problem exists in the heater.

IF VALVE DOES NOT MOVE: Check for voltage out at TB2-1: Should be a 1VDC to 10VDC output to the actuator valve. If no voltage is present, check for voltage at pin FS on the control board, there should be a 12VDC signal. If the 12VDC signal is not present, verify that the converter is wired correctly using the wiring diagram.

IF INLET TEMP ERROR is illuminated: The setpoint temperature has not been reached within the 7 minute time period.

- Push the Reset Switch (see Fig. 9) or remove power and watch for proper operation.

- Check pump sizing and valve/piping sizing and correct as necessary.

IF SENSOR OUT OF RANGE LED is illuminated: The sensor may have a short or open circuit.

- Press and release the Reset Switch (see Fig. 9) and watch for proper operation.
- Replace sensor.
- Check wiring using wiring diagram.

Mounting the Actuator to the Valve

When mounting the actuator to the valve, ensure that the valve stem is oriented with the machined flat notch positioned parallel to the “A” and “AB” ports as shown in Fig. 15.

All actuators used by Raypak include the “spring return” safety feature. This means that upon loss of power during operation the valve automatically rotates back to the full system flow position avoiding high limit lockouts or other issues.

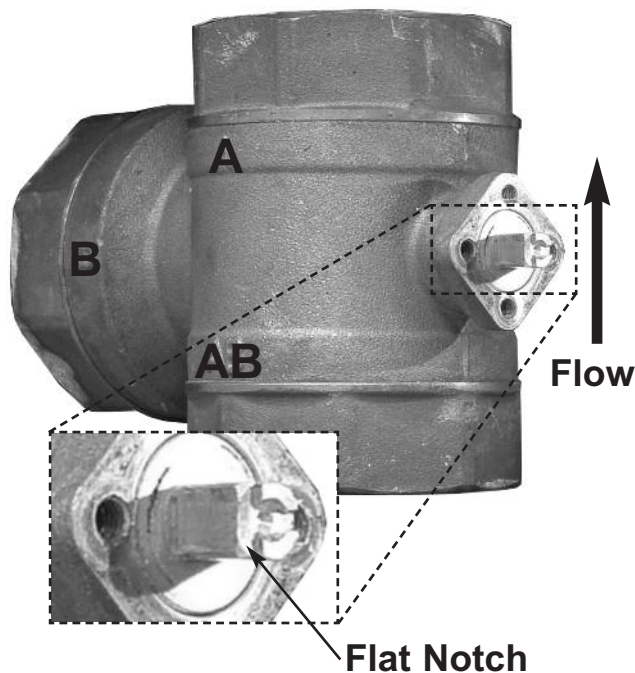

Fig. 15: Orient Notch Parallel with “A” and “AB” Ports

Mounting Brackets (Elodrive)

There are different actuator mounting brackets on the three-way valves. When ordering a replacement bracket you will receive the newest design available from the manufacturer. If it appears to be different than the damaged bracket, the new and old are interchangeable and will fit all valve bodies. See Fig. 16.

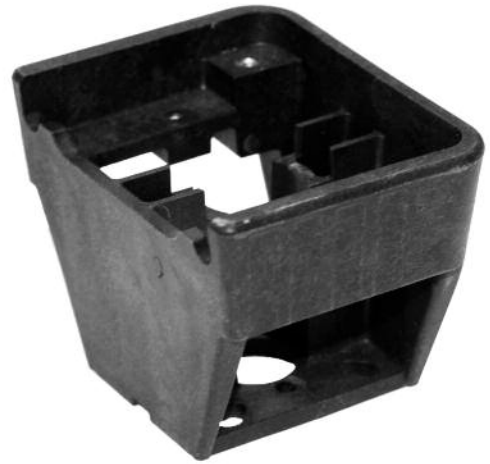

Fig. 16: Elodrive Mounting Bracket

Locating the Rotation Stop (Elodrive)

An internal rotation stop device is built into the actuator mounting bracket and this can be installed only two ways for proper operation of the valve. The stop is labeled on each side with either “D” or “P”. This indicates that the valve is set up for either a diverting application or proportional (mixing) application. Raypak uses the three-way valve in a mixing application therefore the “P” designator must be facing away from the bracket.

The valve rotates in a clockwise direction when it is operating. The rotational stop must be positioned so that the drive linkage can rotate. The drive linkage is keyed to allow only 90 degrees of rotation. Ensure that the key is positioned so the linkage may rotate clockwise as shown in Fig. 17.

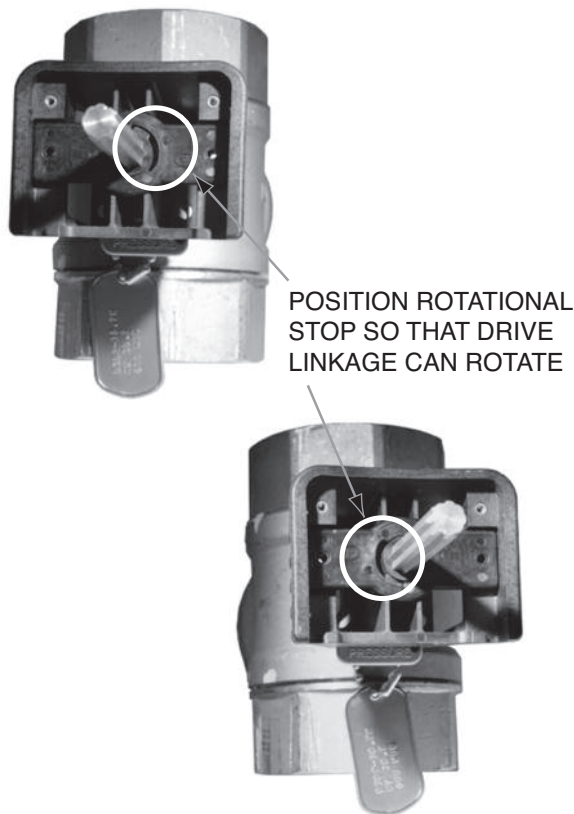

Fig. 17: Elodrive Rotational Stop Positioning

Drive Linkage (Elodrive)

The drive linkage for the 2" NPT and 2-1/2" NPT three-way valves originally were supplied with an orientation groove in the end of the stem. This groove has now been removed by the vendor. All new linkage stems will have a smooth end. Using the groove to determine ball position inside of the valve is not reliable and should be avoided.

Verifying Ball Position

All field-installed valves must have the ball properly positioned. Occasionally differences occur from the manufacturer of the valve body. The square stem that the drive linkage attaches to should have a machined notch to verify ball position, however on occasion it is not there. To properly orient the ball follow these instructions **PRIOR** to installation into your plumbing system.

- Remove the actuator and base from the valve body.
- With port "AB" facing you, rotate the valve stem approximately 45 degrees clockwise. You must see two port openings if the ball is correctly oriented.

- If you do not see two openings at this point, continue rotating the stem and ball until you do.
- Once you can see two openings, **STOP**, as shown in Fig. 18. Then rotate the stem counterclockwise until only one opening remains e.g. you can see completely through the valve (through ports A and AB).

Now the ball is correctly oriented inside of the valve body. Reassemble the valve, base and actuator, and then install the assembly into your piping system as indicated in this manual.

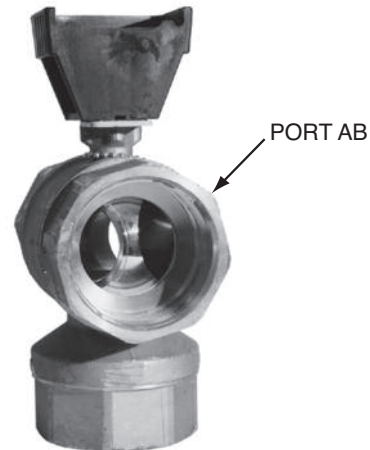

Fig. 18: Verifying Ball Position

Actuator to Valve Orientation

Install the actuator so that the tail is pointing downward as shown in Fig. 19. You may also install it horizontally, however, **DO NOT** mount it so that the tail is pointing up as shown in Fig. 20. Doing so will allow water and debris to collect in the cup where the wiring exits the actuator, potentially causing damage.



Fig. 19: Recommended Orientation of Actuator



Fig. 20: Incorrect Orientation of Actuator

Installing the Three-Way Valve

When threading any pipe into the ports of the three-way valve, a backing wrench **MUST** be employed. You must capture the valve body with a secondary wrench to avoid damaging the internal seals. Valve bodies leaking from improper installation are non-warrantable.

High Pressure Tab

Located between the valve body and the actuator mounting bracket, is a yellow tab labeled “High Pressure” see Fig. 21. This is for maintenance of the valve only.

If the valve stem begins leaking beneath the yellow tab the internal packing material must be replaced. The “High Pressure” tab is held on with two screws located under the mounting bracket.

To replace the packing material, all water pressure must be removed from the valve assembly and the assembly must be isolated from the system water. Then remove the actuator and bracket, then remove the two screws holding the “High Pressure” tab in place.

At this point the packing material can be removed and replaced just like any other valve assembly. The packing material is not available from Raypak.

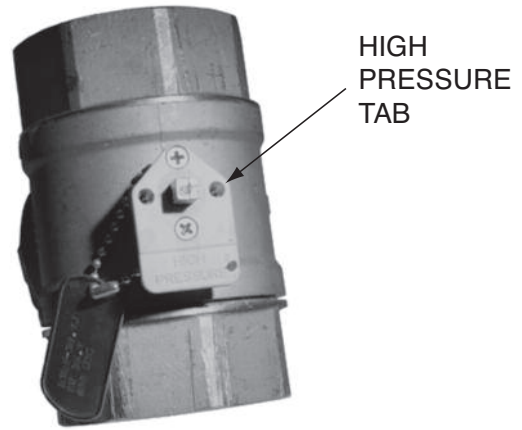

Fig. 21: High Pressure Tab

Actuator

The ELODRIVE actuator has a manual override for the valve. The label located over the silver colored primary label states, “Please read manual before using manual override”. Using the Allen wrench supplied with the loose valve, place it in the hexagonal opening under the label. See Fig. 22.

By pressing the red release button on the tail of the actuator and simultaneously rotating the Allen wrench you can rotate the ball clockwise. Once you release or remove the Allen wrench the ball will return to its original position by way of the “spring return”. This is an easy way to determine if the ball is oriented properly inside of the valve.



Fig. 22: Actuator

Cold Water Start Troubleshooting Guide

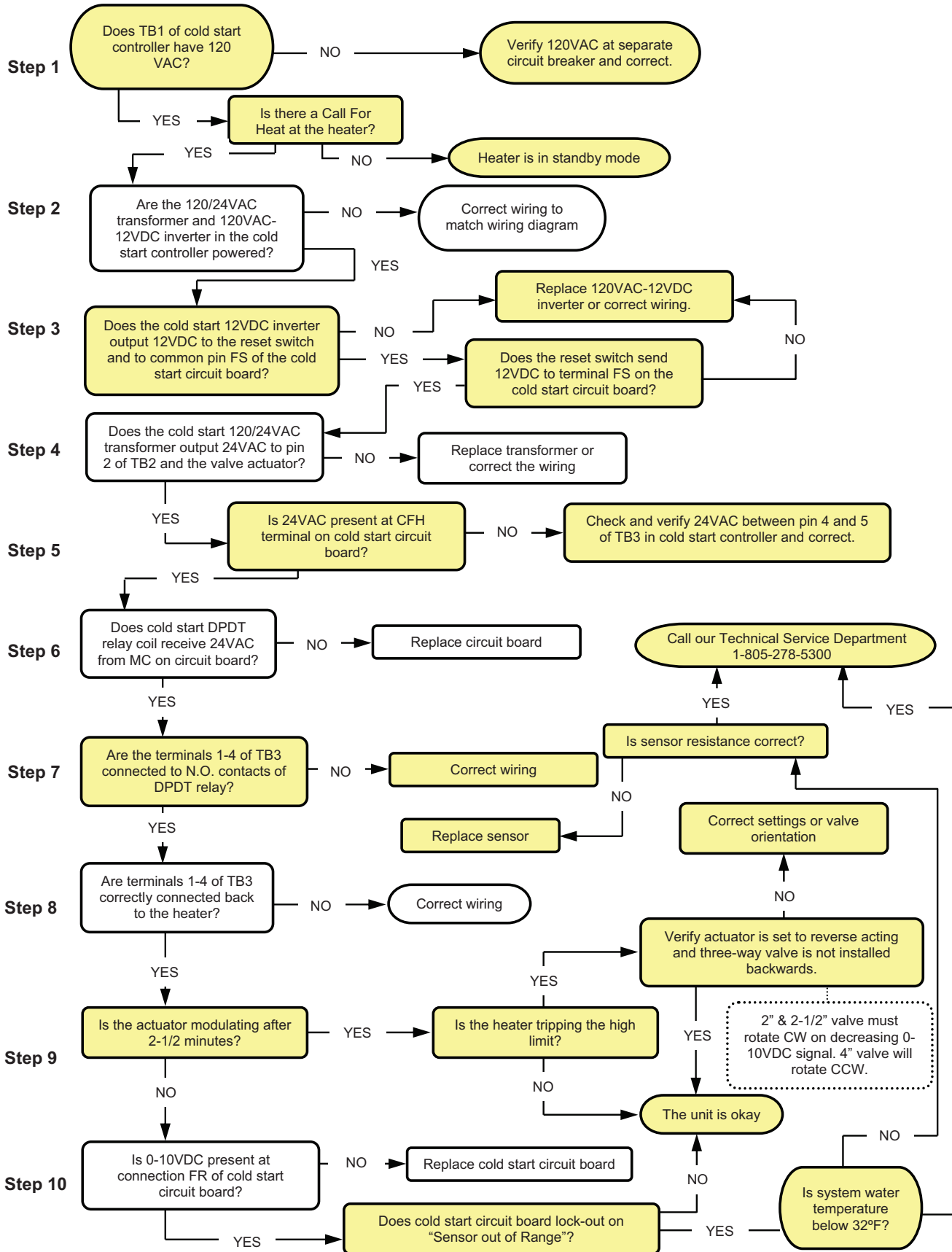

Typical Cold Water Start Piping

NOTES:

1. LOCATE UNIONS TO FACILITATE SERVICING OF PLUMBING SIDE.
2. PLUMB SWING CHECK VALVE IN GRAVITY-CLOSED POSITION.
3. PIPE ALL RELIEF VALVES TO DRAIN, OR AS LOCAL CODES REQUIRE.
4. BUFFER TANK REQUIRED WHEN WATER VOLUME IN BOILER LOOP IS NOT ADEQUATE TO PROVIDE STABLE TEMPERATURE CONTROL. CONSULT FACTORY FOR TANK SIZING.
5. SYSTEM FLOW MUST EXCEED HEATER FLOW AT ALL TIMES.

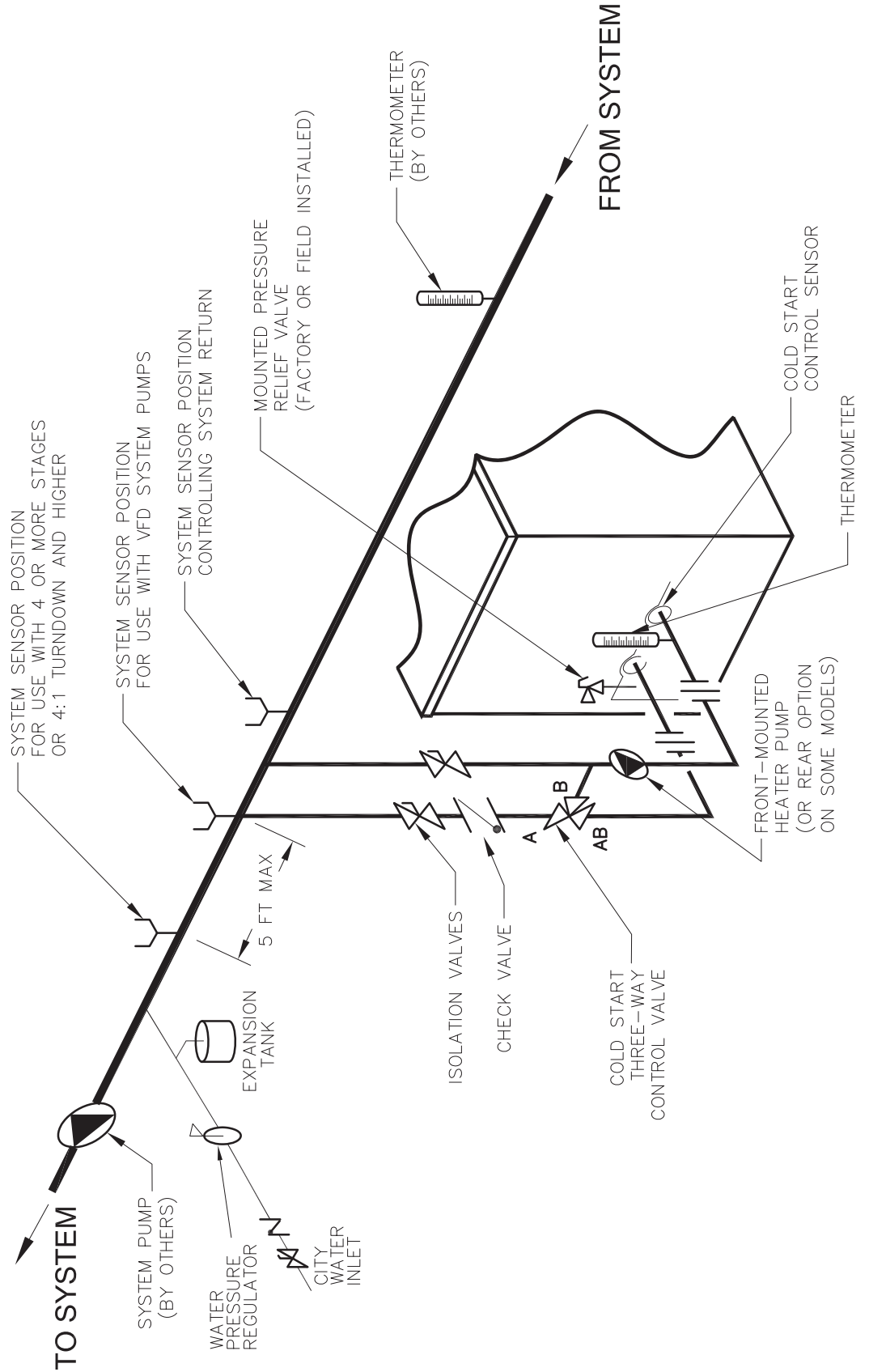

Wiring Diagrams—Cold Water Start

COLD START CONTROL ASSEMBLY

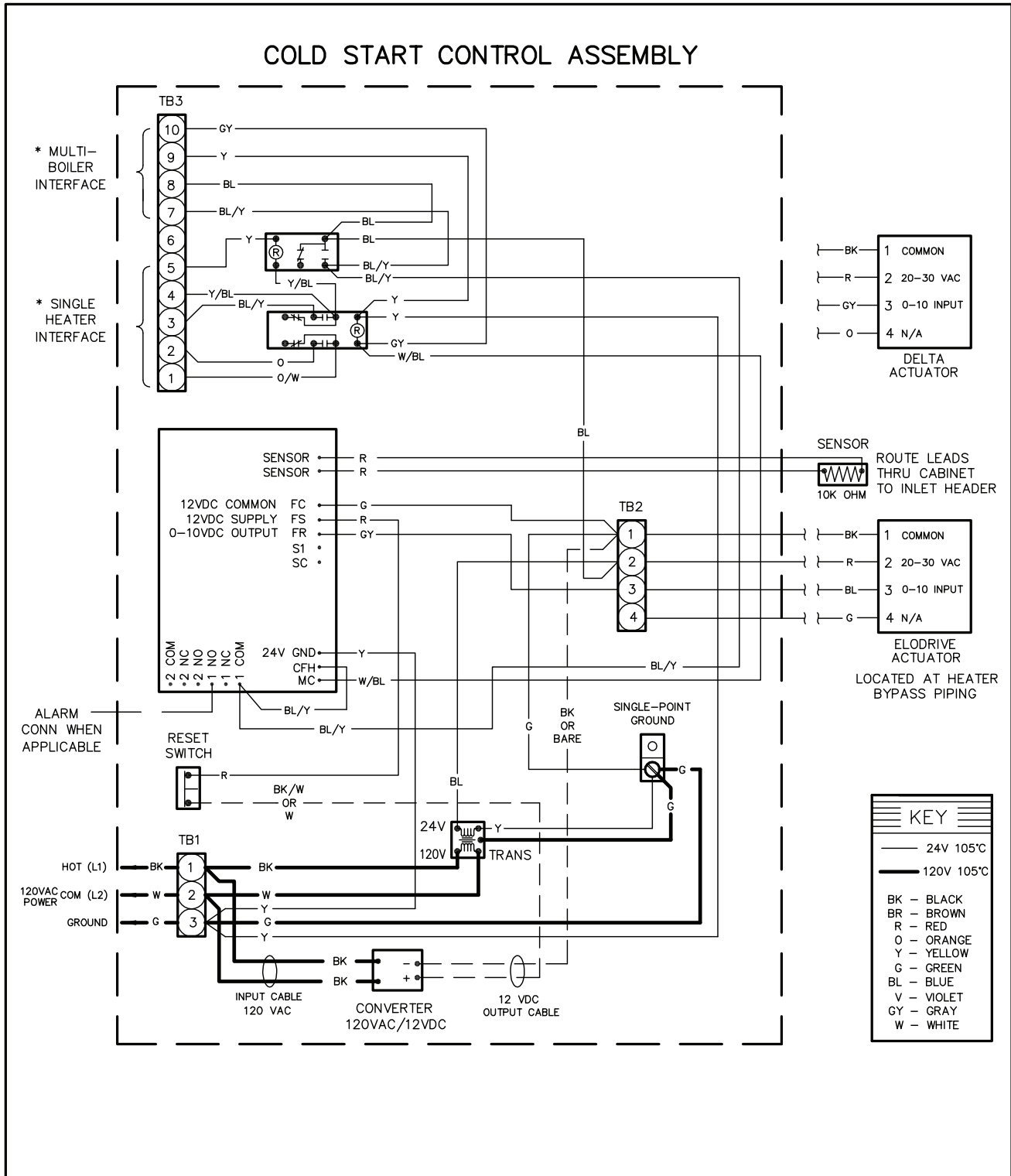

HEATER INTERFACE WIRING FOR CWS OR CWR

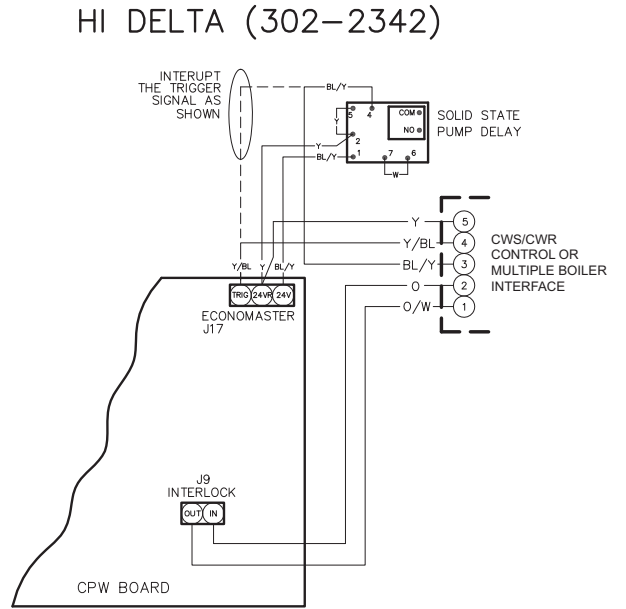
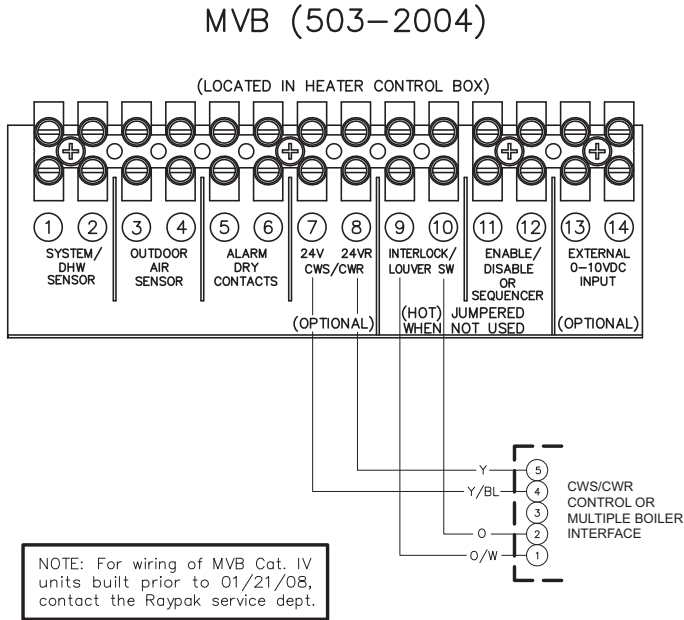

RAYTHERM

(SOME COMPONENTS REMOVED FOR CLARITY)

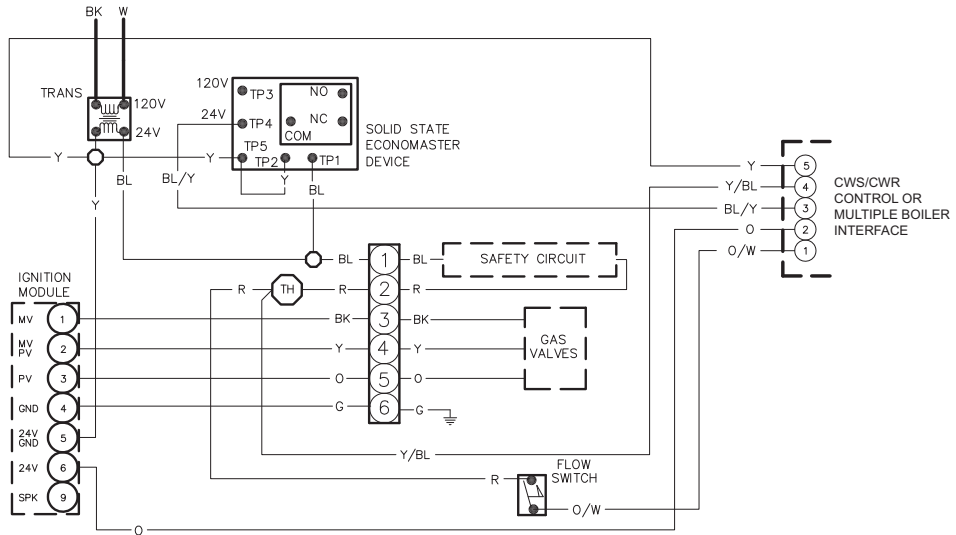

COLD WATER START— MULTIPLE HEATER (Maximum 4 heaters)

Materials Included

- 1 Cold Start Control Box
- 1 Multi-Boiler Interlock Box
- 1 Water Sensor & Well
- 1 Three-way Diverting Valve assembly with Actuator

NOTE: Flanges, bolts and gaskets for flanged valves supplied by others.

Installation

Mounting the Control Boxes

Cold Start Control and Multi-Boiler Interlock should be mounted in such a manner as to allow for easy access for wiring of the boiler interlock connections.

Installing the Temperature Sensor

Temperature sensor to be installed in a drywell with thermal paste at the location indicated in the diagram on page 21 to ensure proper operation of the control system. Installer must ensure the drywell extends at least 2 inches into the water flow path. Sensor wiring must be run in separate conduit from line voltage and should be a minimum of 18 AWG shielded cable. Refer to diagram on page 22 for wiring information.

Installing the Three-way Valve

Install three-way diverting valve into common boiler piping manifold as shown in the diagram on page 18. Boiler common outlets to be connected at port AB. Discharge to system from port A with bypass port being port B. Common pipe sizing may be larger than three-way valve port connections requiring the use of increasers for installation (see Table B for valve sizing). It is recommended that three-way valve be installed as near the main system piping as is feasible. Route control wiring in separate conduit to the Cold Water Start control box and wire as shown in the diagram on page 19.

Connecting Power to the Controller

Installer to provide a dedicated 120V circuit with local disconnect to the Cold Water Start Control. Refer to wiring Fig. 9 on page 8 for detailed instruction.

Connecting Cold Water Start to Multi-Heater Interlock Box

Installer to provide four 18AWG stranded wires between pins 7-10 on the Cold Start Control and 7-10 on the Multi-Boiler Interlock as shown in the diagram on page 22. Do not use solid core wire when wiring any portion of the Cold Start Multi-Boiler system.

Connecting Heater to Cold Water Start Multi-Heater Interlock

Installer to provide five 18AWG stranded wires between each boiler and Multi-Boiler Interlock box. Wiring to be run in separate conduit from line voltage to ensure proper operation. Refer to the diagram on page 22 for connection points depending on Raypak product being used.

Total Load (MBTU)	Valve Size	Minimum Pipe Size	Cv	Flow Rate (gpm)	Valve Pressure Drop	ΔT @ Max Size	ΔT @ Min. Size	Order No.
600-1000	2" NPT	2	57	70	3.5 ft	22	14.4	012228
1001-1800	2.5" NPT	2.5	74	100	4.2 ft	30.2	16.8	012229
1801-2600	2.5" NPT	3	100	150	5.2 ft	29.1	20.1	012230
2601-4000	4" FLG*	4	152	220	4.8 ft	30.5	22.9	012231
4001-6000	4" FLG*	4	254	330	3.9 ft	30.5	20.3	012232
6001-8000	4" FLG*	6	327	440	4.2 ft	30.5	22.5	012233

Standard boiler pump options offered by Raypak may **NOT** be appropriate for these applications.

*CAUTION: Approved for closed loop systems only.

Table B: Valve Sizing Chart

Actuator to Valve Orientation

Install the actuator so that the tail is pointing horizontally as shown in Fig. 26 or is pointing down. DO NOT mount it so that the tail is pointing up as shown in Fig. 20. Doing so will allow water and debris to collect in the cup where the wiring exits the actuator, potentially causing damage.

Three-Way Valve Ball Orientation

The ball orientation must be verified prior to mounting the flanged valve into the piping system. With the flanged four-inch valve it is a fairly simple procedure. Do not use the groove on the end of the drive linkage to verify.

First, remove the actuator by removing the wing-nut underneath the mount bracket near the tail. Second, loosen the locking bolt on top of the actuator that clamps to the drive linkage. See Fig. 23.

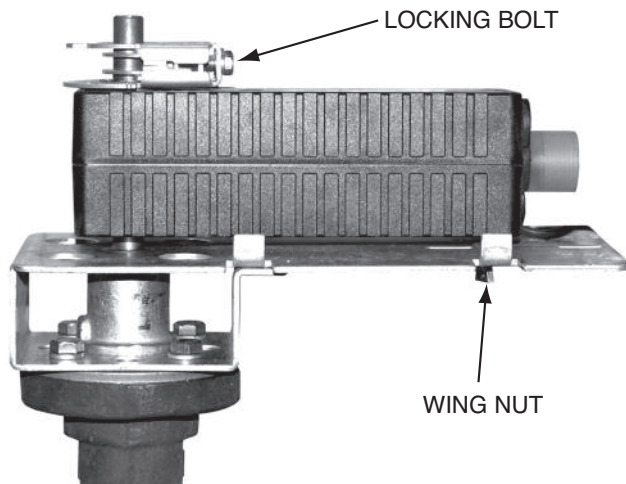

Fig. 23: Removing the Actuator (Elodrive)

Once this has been done, remove the actuator by lifting straight off the drive linkage shaft.

Now the ball position must be verified. Using pliers, grasp the base of the drive linkage. While looking into port AB, rotate the drive linkage counterclockwise about 45 degrees. See Fig. 24. You should see two partial openings similar to Fig. 18.

If you do not see the two partial openings after 45 degrees of rotation, continue rotating until you do. Once you see the two partial openings, STOP. Now rotate the shaft in the reverse direction (clockwise) until you can see straight through to valve from port AB to port A.

Reinstall the actuator and bracket assembly in reverse order, and ensure that the ball assembly is properly oriented. Mount the flanged valve into your piping system in accordance with this manual.

Valve Installation

To properly install this valve port "AB" must be connected to the combined outlet of the heater(s); and port "B" must be attached to the bypass between the combined inlet and the combined outlet, as shown on page 21. The valve body has the port designators cast into the drive linkage housing. See Fig. 25.

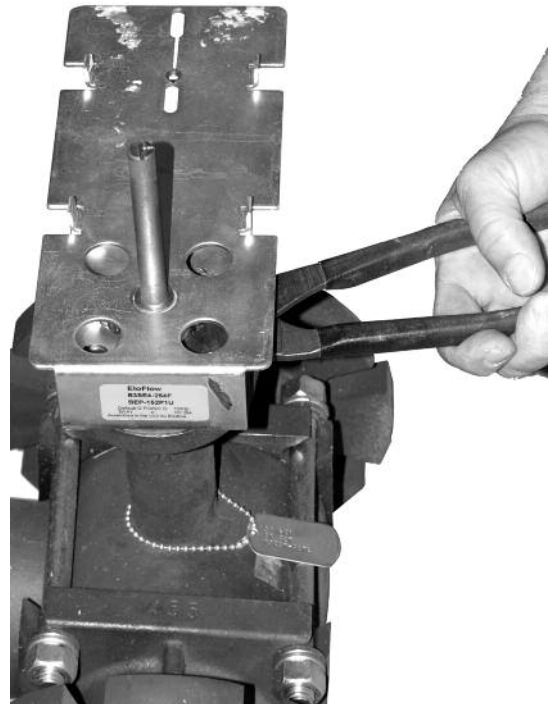

Fig. 24: Rotating the Drive Linkage

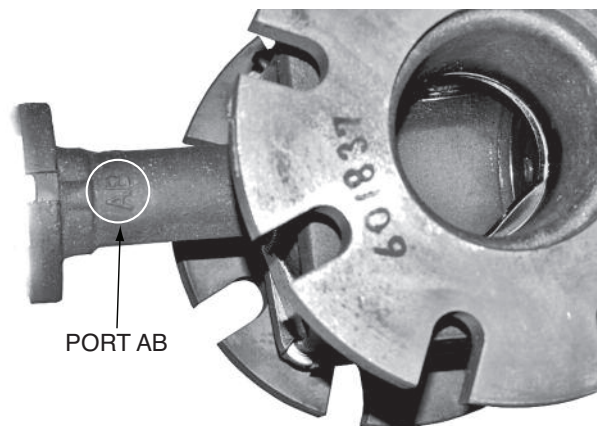

Fig. 25: Valve Orientation

4-Inch Valve Orientation

The valve must be installed so that the combined boiler outlets enter through Port "AB" (See Fig. 26). Port "B" is the bypass port and port "A" is the return to the system (port designations are cast into the stem of the valve body). The valve body should be installed so that the actuator input shaft is in the vertical or horizontal position. The Actuator stem should never be hanging downward.

The actuator, as shipped from the factory, is in the horizontal position when the valve is installed as shown in Fig. 26. The actuator position can be changed to suit job site conditions.

Under no circumstances should the actuator be positioned such that the electrical connection is pointing upwards (see Fig. 20) as this can allow for moisture or debris to enter the actuator assembly and potentially damage the actuator.

Before installing into the piping system, verify the valve is positioned properly by referring to Fig. 26 and the diagram on page 21.

Connecting the Actuator

The 4-inch valve is shipped loose, and must be field wired. Connect the actuator leads to the Cold Water Start control panel, as indicated in the wiring diagram on Page 16.

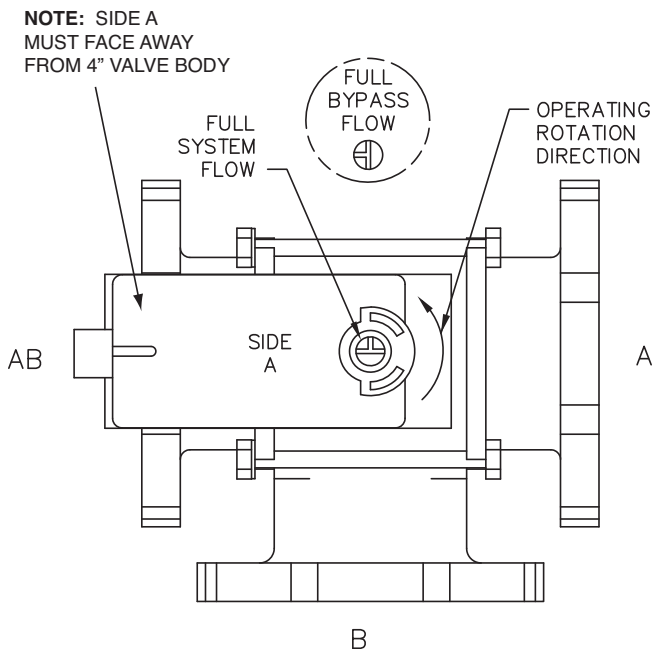

Fig. 26: Valve Orientation (Elodrive Actuator)

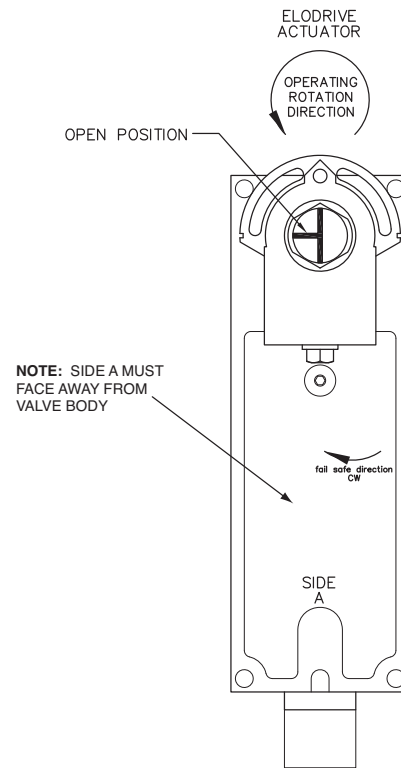

Fig. 27: Elodrive actuator used on 4" valves (Actuator shown in full system flow position.)

The actuator for the 4" valves rotates opposite to the direction of the smaller actuators. On an Elodrive actuator, Side A must be facing away from the valve.

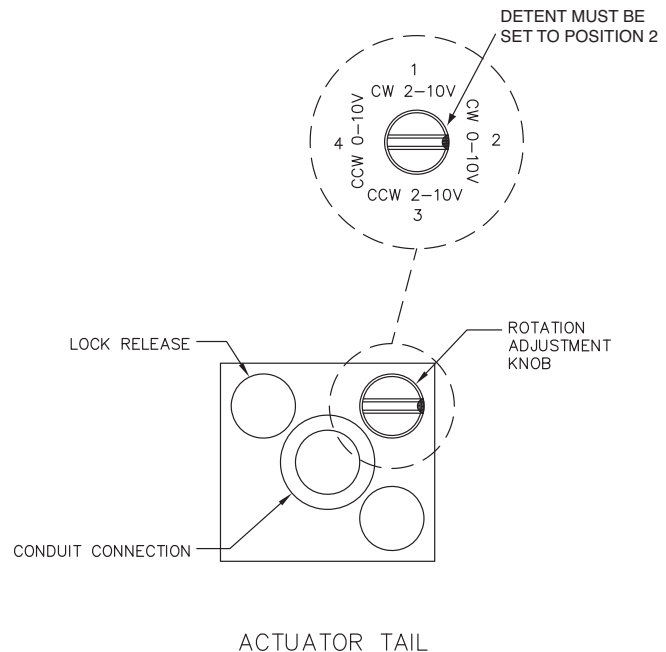
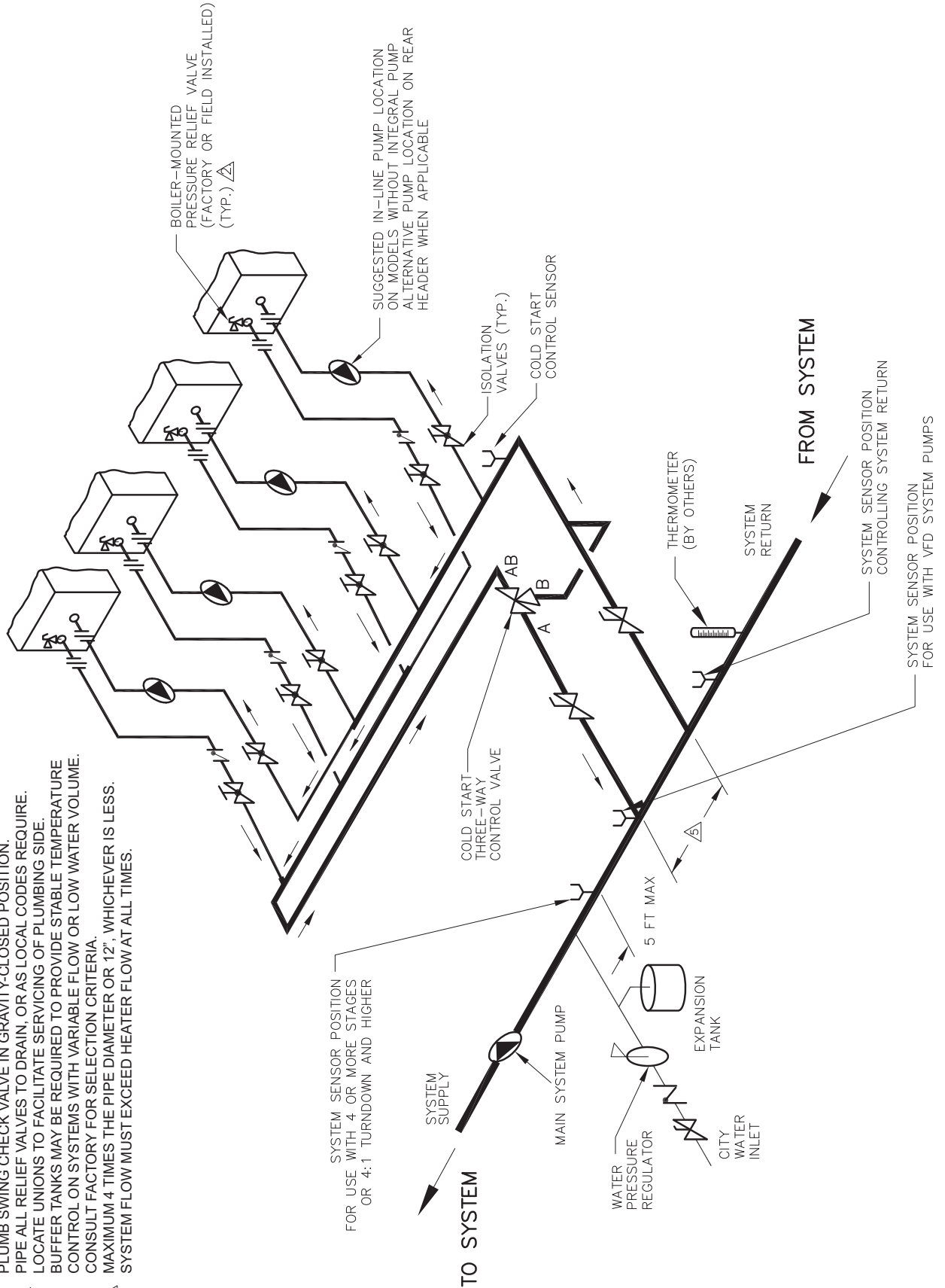

Fig. 28: Rotational Setting for Elodrive Actuator Used on 4" Valves

Typical Cold Water Start Multiple Heater Piping

NOTES:

1. PLUMB SWING CHECK VALVE IN GRAVITY-CLOSED POSITION.
2. PIPE ALL RELIEF VALVES TO DRAIN, OR AS LOCAL CODES REQUIRE.
3. LOCATE UNIONS TO FACILITATE SERVICING OF PLUMBING SIDE.
4. BUFFER TANKS MAY BE REQUIRED TO PROVIDE STABLE TEMPERATURE CONTROL ON SYSTEMS WITH VARIABLE FLOW OR LOW WATER VOLUME. CONSULT FACTORY FOR SELECTION CRITERIA.
5. MAXIMUM 4 TIMES THE PIPE DIAMETER OR 12", WHICHEVER IS LESS.
6. SYSTEM FLOW MUST EXCEED HEATER FLOW AT ALL TIMES.



Wiring Diagram Multiple Heater

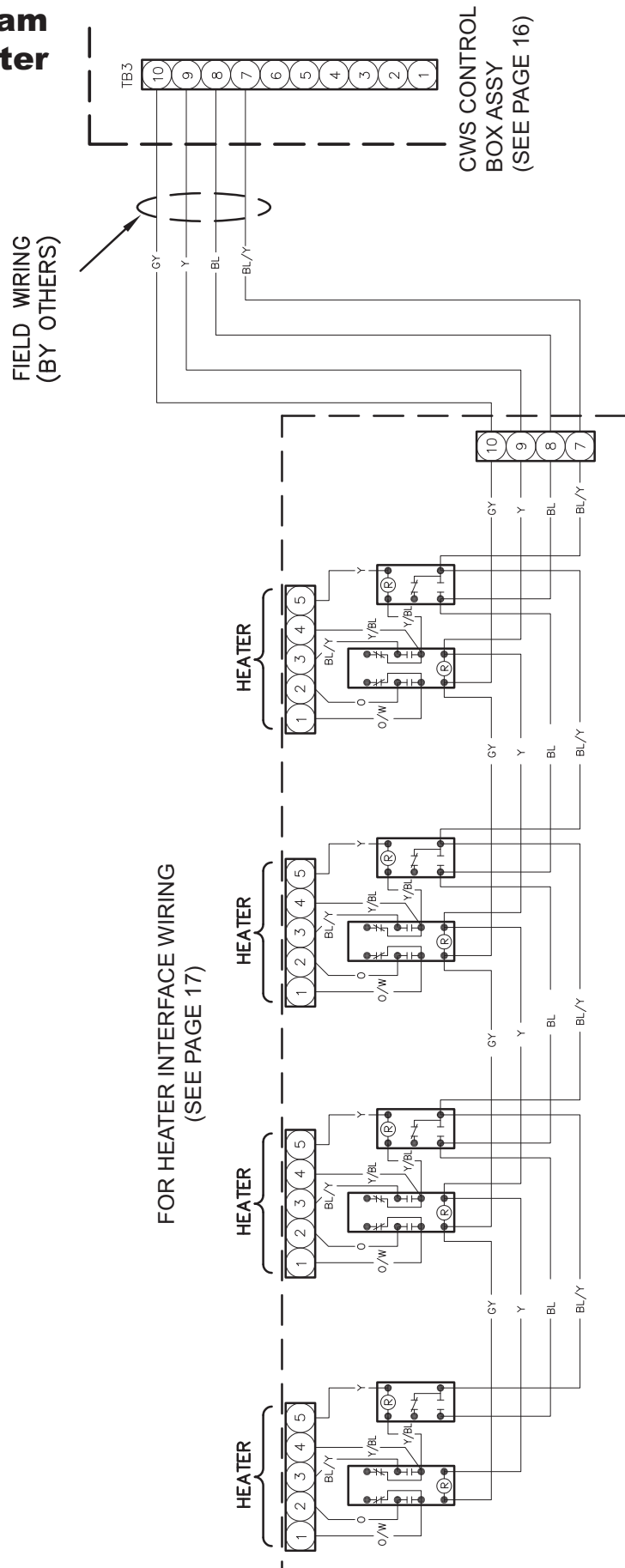

FIELD WIRING
(BY OTHERS)

CWS CONTROL
BOX ASSY
(SEE PAGE 16)

MULTIPLE BOILER CONTROL ASSEMBLY

COLD WATER RUN

NOTE: After testing at the factory it may be prudent to ship the piping assembly disassembled and attached to the heater pallet. This is done to avoid shipping damage and it must be reassembled on the jobsite. Use Fig. 29 to assist you in reassembling the piping.

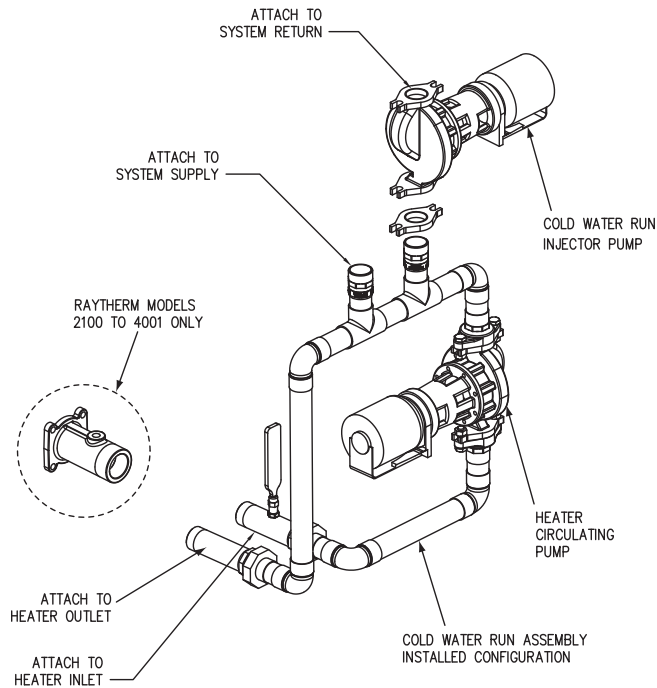

Fig. 29: Cold Water Run Assembly

Purpose

The Cold Water Run system utilizes a variable-speed pump to inject the proper amount of water from the main system loop into the heater to maintain the optimum inlet temperature. This approach allows the full capacity of the heater to be utilized to meet the system load, while at the same time continuously maintaining the optimum inlet water temperature to prevent condensation.

Typical Cold Water Run Applications

- Swimming pools.
- Any system with steady-state (or “consistent”) return water temperature below 105°F.

CWR vs. CWS

- Cold water start is for transient cold water operation.
- Cold water run is for continuous operation below 105°F system return temperature.
- Cold water start maintains design flow rate at system design temperature but reduces boiler flow rate during heavy bypass operation.
- Cold water run maintains constant design flow rate in the boiler.

Installation

Before beginning the installation, it's important to first inspect the system and determine what materials you will need. Some parts are included with the controller while others you will need to provide.

Installation Codes

Installations must be in accordance with local, state, provincial, and national codes, laws, regulations and ordinances. In the absence of local codes, installations must be in accordance with the latest editions of the:

- National Fuel Gas Code, ANSI Z223.1/NFPA 54
- National Electrical Code, ANSI/NFPA 70
- For Canada only: CAN/CSA B149 Installation Code and CSA C22.1 C.E.C. Part 1 and Part 2

Mounting the Control Box

NOTE: The heater should not be located in an area where possible water leakage will result in damage to the area adjacent to the heater or to the structure. When such locations cannot be avoided, it is recommended that a suitable drain pan, with adequate drainage, be installed under the heater. The pan must not restrict combustion air flow.

The control box should be mounted on the side of the heater to which the system piping and pump assemblies are to be attached as shown in Figs. 4–8 on pages 7 & 8. The controller should be mounted so as to provide maximum support by using the mounting holes provided on the base of the controller to the side center brace on the heater. You will need to drill mounting holes for #10 hardware and 3/4” conduit access holes through the heater side panel for the routing of wiring and the sensor.

CAUTION: Remote mounted controller must be installed within 25 feet of wire length to the heater.

Injector & Heater Pump Comparison

Heater Model	Heater Pump				Injector Pump		
	Flow	Temp. Rise	Press. Drop	Pump Model/Imp.	Flow	Temp. Rise	Pump Model-hp
302	32	16	2	112	13	40	1911-¼ hp
402	34	20	2	112	17	40	1911-¼ hp
502	42	20	2.3	1630/4.0	22	40	1911-¼ hp
652	55	20	4.1	1630/4.0	28	40	1911-¼ hp
752	63	20	5.7	1630/4.2	32	40	1911-¼ hp
902	76	20	8.4	1630/4.2	38	40	1911-¼ hp
992	83	20	5.2	1630/4.7	42	40	1911-¼ hp
1262	107	20	9.6	1630/4.7	54	40	1911-½hp
1532	120	22	12.4	1632/5.6	62	42	1911-½hp
1802	120	25	13	1632/5.6	68	45	1911-½hp
2002	132	26	19	1634/6.1	74	46	1935-¾hp
2072	132	27	19	1634/6.1	75	47	1935-¾hp
2342	132	30	21.4	1634/6.1	80	50	1935-¾hp

Table C: Injector and Heater Pump Specifications—Hi Delta

Heater Model	Heater Pump				Injector Pump		
	Flow	Temp. Rise	Press. Drop	Pump Model	Flow	Temp. Rise	Pump Model-hp
503	58	15	2.4	1611	29	30	1911-¼ hp
753	63	21	5.6	1611	44	30	1911-¼ hp
1003	87	20	8.2	1630	58	30	1911-½ hp
1253	86	25	12.2	1630	73	30	1911-½ hp
1503	100	26	18.5	1632	87	30	1911-½ hp
1753	109	28	26	1634	102	30	1911-½ hp
2003	116	30	36.2	1636	116	30	1935-¾ hp

Table D: Injector and Heater Pump Specifications—MVB

Heater Model	Heater Pump				Injector Pump		
	Flow	Temp. Rise	Press. Drop	Pump Model/Imp.	Flow	Temp. Rise	Pump Model-hp
926/962	79	20	8.5	1630/4.7	50	32	1911-¼ hp
1083/1125	90	21	12.0	1630/4.7	50	37	1911-¼ hp
1178/1223	90	22	12.5	1630/4.7	60	33	1911-½ hp
1287/1336	90	25	13.2	1630/4.7	60	37	1911-½ hp
1414/1468	90	27	14.0	1632/5.65	60	40	1911-½ hp
1571/1631	90	30	14.5	1632/5.65	60	45	1911-½ hp
1758/1826	90	34	15.4	1632/5.65	60	50	1911-½ hp
2100	172	20	11.0	1641/6.9	130	26	1935-¾hp
2500	200	21	15.8	1641/6.9	130	32	1935-¾hp
3001	200	25	16.7	1641/6.9	130	38	1935-¾hp
3500	200	29	17.5	1641/6.9	130	44	1935-¾hp
4001	200	33	18.7	1641/6.9	130	50	1935-¾hp

Table E: Injector and Heater Pump Specifications—Raytherm

Check the Power Source

WARNING: Using a multi-meter, check the following voltages at the circuit breaker panel prior to connecting any equipment. Make sure proper polarity is followed and house ground is proven.

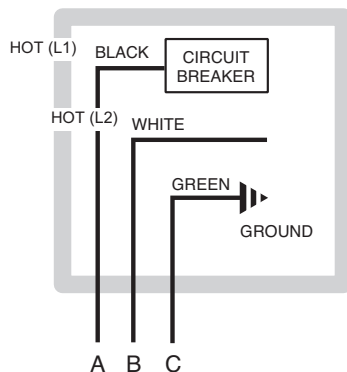

Fig. 30: Wiring Connections

Check the power source:

AC = 104 VAC Minimum, 126 VAC MAX
 AB = 208 VAC Minimum, 252 VAC MAX
 BC = 104 VAC Minimum, 126 VAC MAX

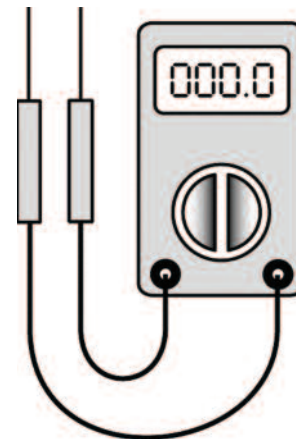

Fig. 31: Multi-meter

Injector Pump Wiring

The 3-phase cold water run pump is shipped loose and must be field wired.

Before Starting

1. Turn off power to the unit at the circuit breaker.
2. Turn off gas supply.
3. Shut off the water supply to the heater and, if necessary, drain water from the system.

4. Locate the pump junction box and wiring decal shown in Fig. 32.

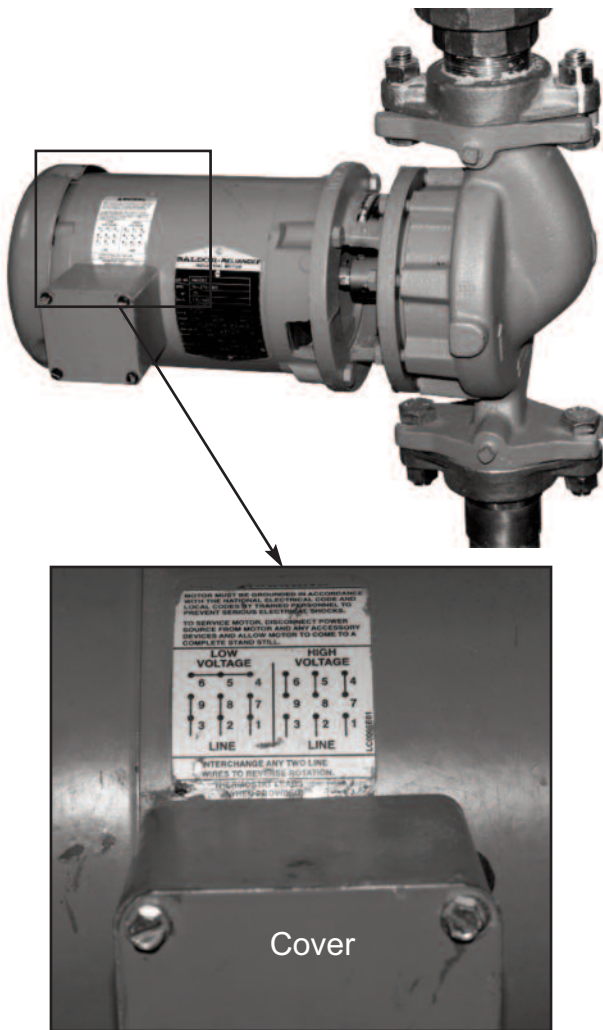

Fig. 32: Pump Wiring Decal and Junction Box

5. Remove the pump junction box cover shown in Fig. 32 and locate the 9 wires inside.
6. Wire in accordance with the low voltage (230 VAC) decal located next to the pump junction box (do not connect high voltage 460 volt power to the control box).
7. In the absence of the pump mounted decal, use Table F to complete the wiring between the cold water run control box and the 3-phase injector pump. Use wire nuts (field supplied) to complete these connections and ensure that all connections are tight.

230 VAC 3 ϕ Line	Low Voltage Pump Wiring
Black	Orange (3) and Gray (9)
Red	Red (8) and White (2)
White	Pink (7) and Blue (1)
_____	Yellow (4) and Black (5) and Violet (6)
Green	Ground Lug

Table F: Cold Water Run Control Panel and Injector Pump Wiring

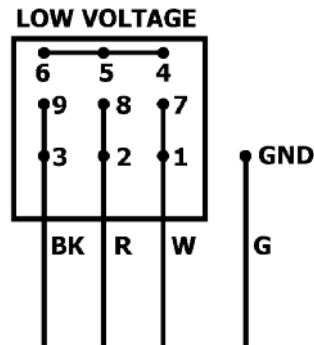

Fig. 33: Cold Water Run Control Panel and Injector Pump Wiring

8. Re-install the injector pump junction box cover.
9. Turn on the water and gas supply.
10. Turn the electrical supply on to the heater and to the cold water run system.
11. Turn heater on to receive a “call-for-heat” and verify the injector pump is rotating in the proper direction (clockwise). The pump volute has an arrow cast into the housing indicating the proper rotational direction. See Fig. 34.

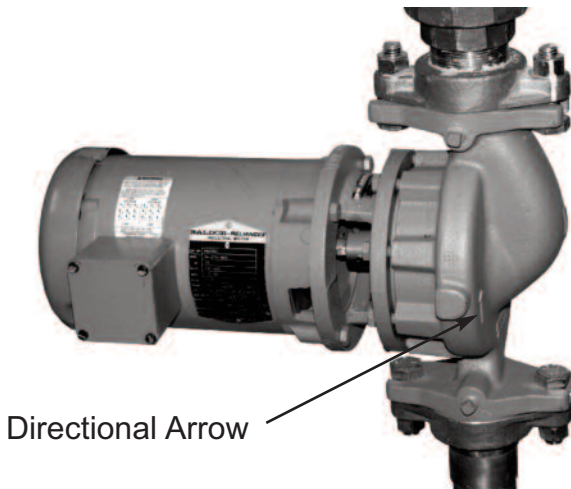

Fig. 34: Directional Arrow

12. If the pump is rotating in the proper direction, secure the heater from installation.
13. If the pump is rotating incorrectly, turn off power and swap ONLY two of the line voltage leads into the pump (for example, swap the red and black leads). Confirm that the pump now rotates in the proper direction before proceeding.
14. Secure from installation.

Injection Pump Cover Installation (Required for Outdoor Installation Only)

Before Starting

1. Turn off power to the unit at the circuit breaker.
2. Turn off gas supply.
3. Shut off the water supply to the heater and, if necessary, drain water from the system.
4. Allow heater to cool down before attempting work.

In order to install the pump cover, you will need to rotate the pump body so that the electrical box is pointing downward, as outlined in the following steps:

1. Loosen and remove the eight (8) 9/16" bolts holding the pump body in place. See Fig. 35.

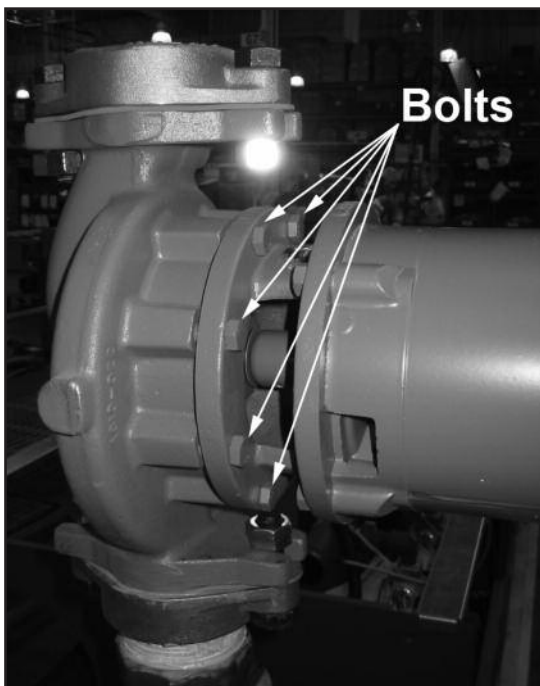

Fig. 35: Remove the eight bolts holding the pump body in place

2. Remove the pump body then rotate it so that the electrical box is pointing downward, ensuring not to damage the seal. See Figs. 36, 37 and 38.

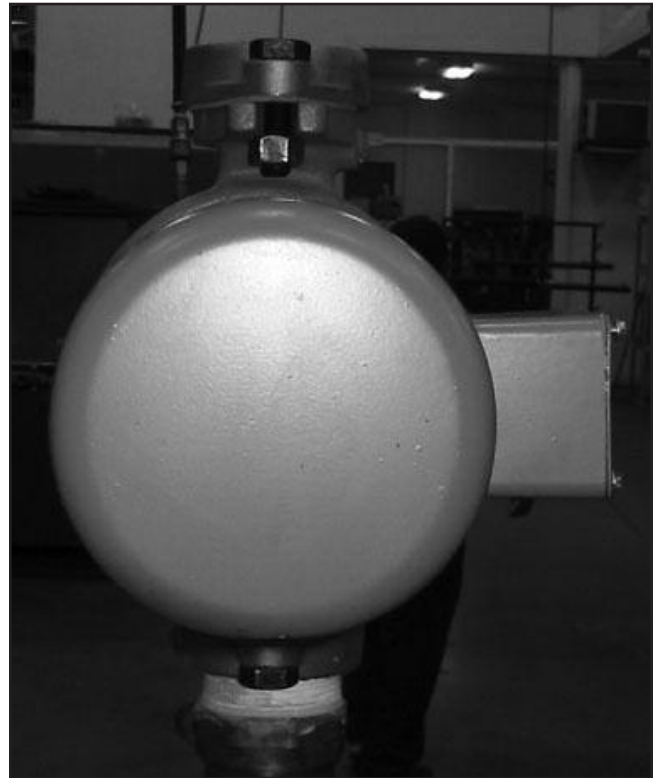

Fig. 36: Remove the pump body



Fig. 37: Be sure not to damage the seal when removing or replacing the pump body

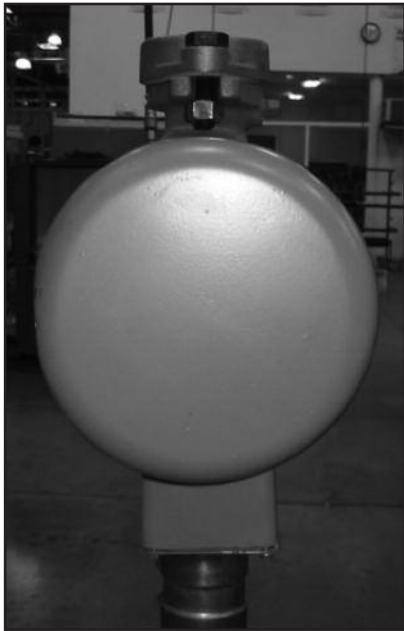

Fig. 38: Reposition the pump body so that the electrical box points downward

3. Insert and tighten all eight (8) bolts, securing the pump body in place.
4. You will now be able to install the pump cover. See Figs. 39 and 40.



Fig. 40: Pump cover - angle view

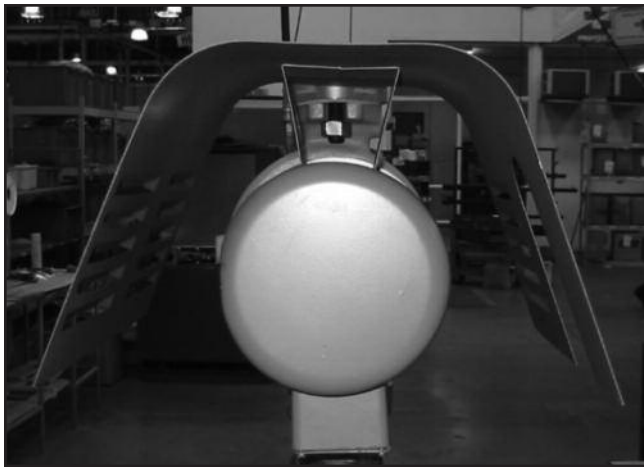
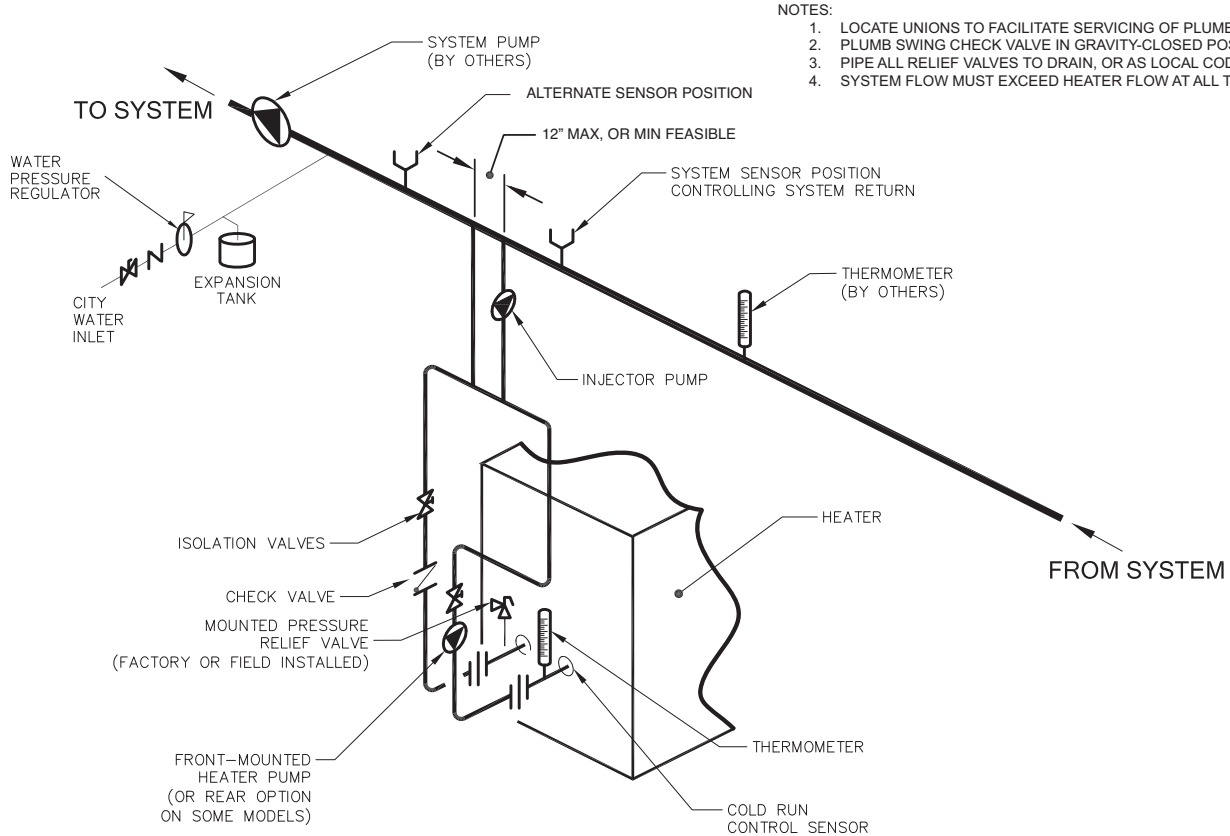

Fig. 39: Place the cover on the pump

Typical Cold Water Run Piping - Heating Applications



- NOTES:
1. LOCATE UNIONS TO FACILITATE SERVICING OF PLUMBING SIDE.
 2. PLUMB SWING CHECK VALVE IN GRAVITY-CLOSED POSITION.
 3. PIPE ALL RELIEF VALVES TO DRAIN, OR AS LOCAL CODES REQUIRE.
 4. SYSTEM FLOW MUST EXCEED HEATER FLOW AT ALL TIMES.

Typical Cold Water Run Piping - Pool Applications

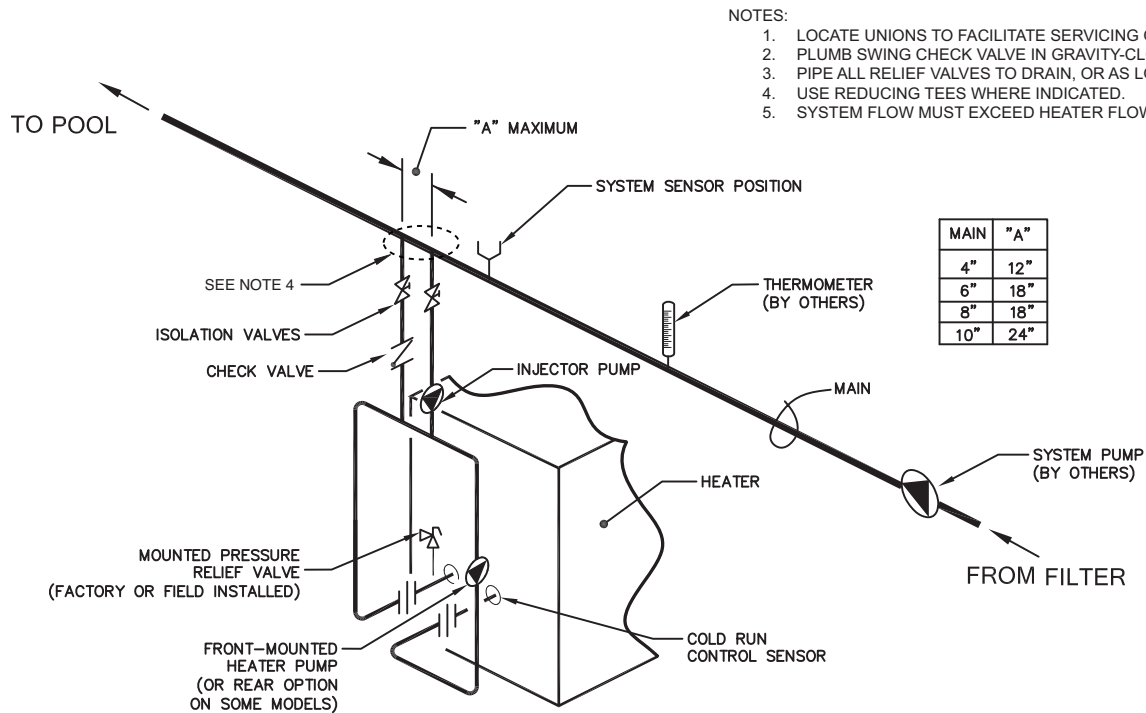

- NOTES:
1. LOCATE UNIONS TO FACILITATE SERVICING OF PLUMBING SIDE.
 2. PLUMB SWING CHECK VALVE IN GRAVITY-CLOSED POSITION.
 3. PIPE ALL RELIEF VALVES TO DRAIN, OR AS LOCAL CODES REQUIRE.
 4. USE REDUCING TEES WHERE INDICATED.
 5. SYSTEM FLOW MUST EXCEED HEATER FLOW AT ALL TIMES.

Operation

- Run full system flow for two minutes.
- Initiate PID pump control to achieve target inlet temperature by slowing injector pump.
- Boiler ΔT will not increase during bypass operation.
- If target temperature is not achieved after 7 minutes from “call for heat”, the system will shut down.

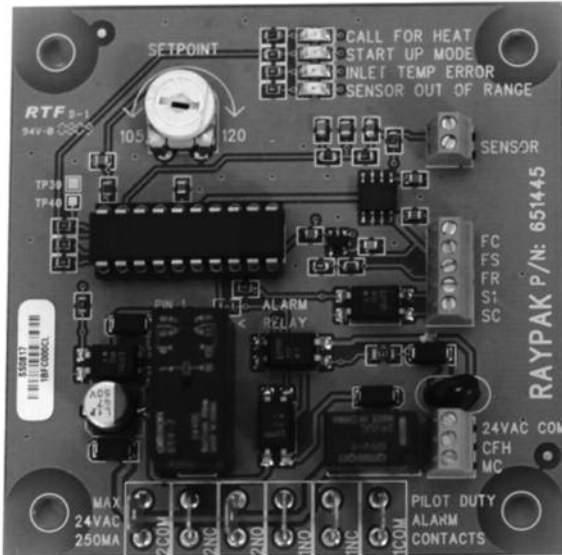

Fig. 41: Control Board

Cold Run Sequence of Operation

1. Supply separate 220VAC, 1 phase, 60 Hz power for the Hitachi Inverter (blue-colored inverter), or 120VAC or 220VAC, 1 phase, 60 Hz power for the AC Tech Inverter (white-colored inverter).
2. Call for heat occurs at heater.
3. The heater outputs 24VAC to terminal 4 of terminal block 3 located in Cold Run controller.
4. Terminal 4 of TB 3 sends 24VAC to the coil of the SPST relay located in the cold run control panel.
5. The SPST relay coil is energized and closes the contacts allowing 24VAC from the Cold Run control transformer to be sent to the CFH terminal of the Cold Run circuit board.
 - a) A two second delay occurs from the CFH signal waiting to send power from terminal MC of the cold run circuit board.
6. 24 VAC is sent from terminal 2 of terminal block 3 to the NO contacts of the DPST relay located in the cold run control panel.
7. After the two second delay on the cold run circuit board, pin MC outputs a 24 VAC signal to terminal AL0 of the Hitachi inverter.
8. The AL0 relay closes and outputs a 24 VAC signal to the coil of the DPST relay located in the cold run control panel.
9. The DPST relay coil energizes and closes the NO contacts.
10. Once the NO contacts of the DPST close, the heater 24 VAC is sent back to the heater to complete the circuit (pin 3 of terminal block 3) and the interlock circuit (pin 1 & 2 of terminal block 3) allowing the heater to fire.
11. Pin SC of the cold run circuit board sends 10VDC to Pin 1 (Forward) on Hitachi Inverter.
12. PCS terminal on Inverter outputs 12VDC signal to the common terminal of the reset switch located on the bottom of the cold run control panel.
13. The 12VDC signal crosses over the reset switch and goes to Pin FS and to pin S1 on cold run circuit board.
14. Pin FR on the TVC board outputs 10VDC to pin O of the Inverter to drive injector pump at full speed for two-minutes waiting for the heater to reach full fire.
15. After the two-minute delay the 10VDC output signal from pin FR reduces to approximately 8VDC at the inverter thus slowing the pump to approximately 50 Hz.
16. The output signal continues to vary depending on the heater inlet temperature.

The heater will lockout and shut down if the set point on the inlet temperature is not achieved within 7 minutes from a call for heat.

The DIP switches on the Hitachi Inverter must be set as indicated on Fig. 42 below.

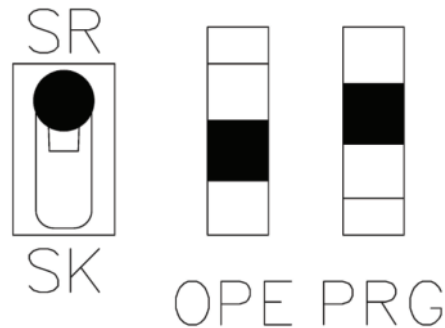
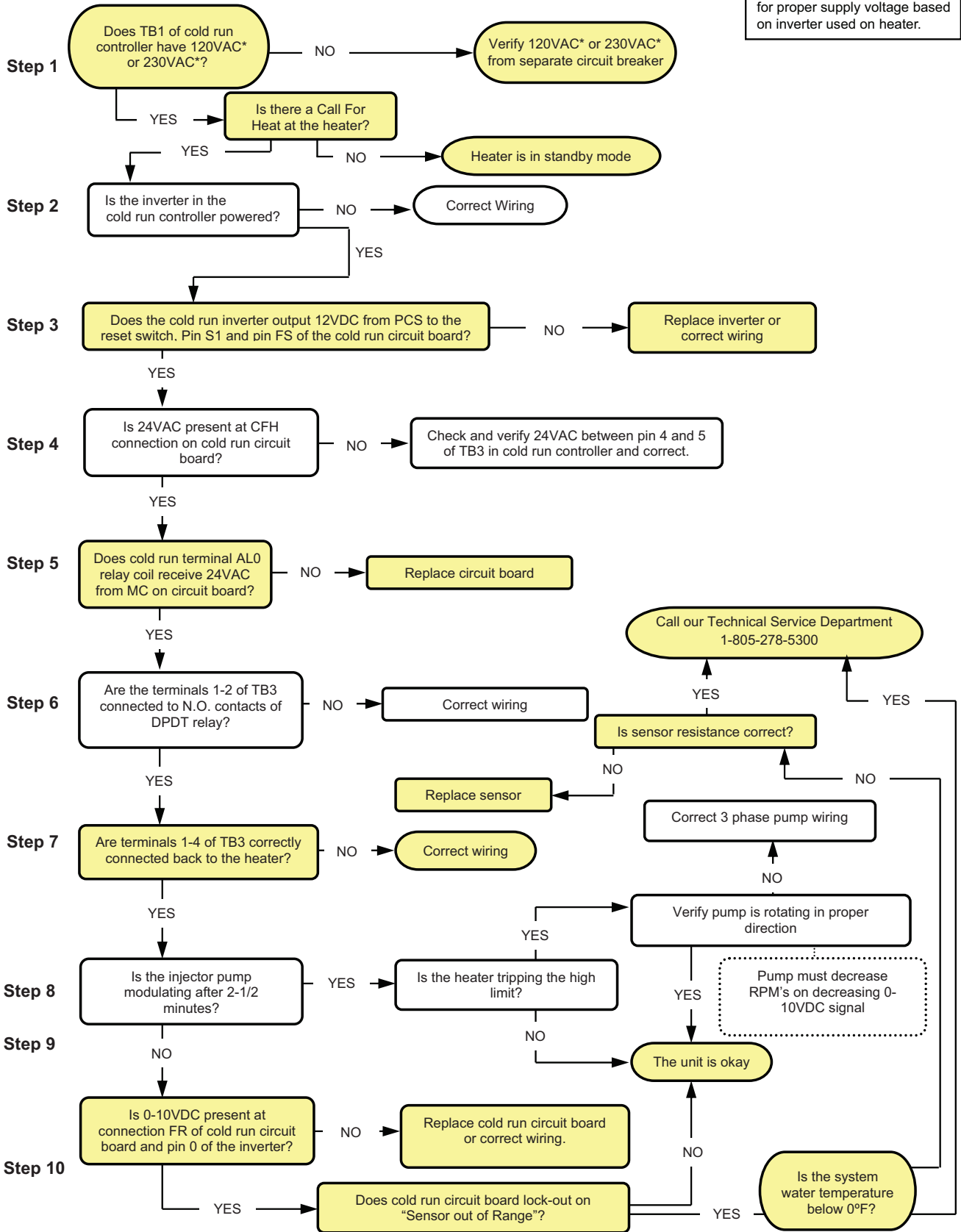

Fig. 42: DIP Switch Settings (Hitachi)

Cold Water Run Troubleshooting Guide

***NOTE:** See wiring diagrams for proper supply voltage based on inverter used on heater.



Wiring Diagram—Cold Water Run (Hitachi Inverter)

COLD RUN BYPASS CONTROL ASSEMBLY

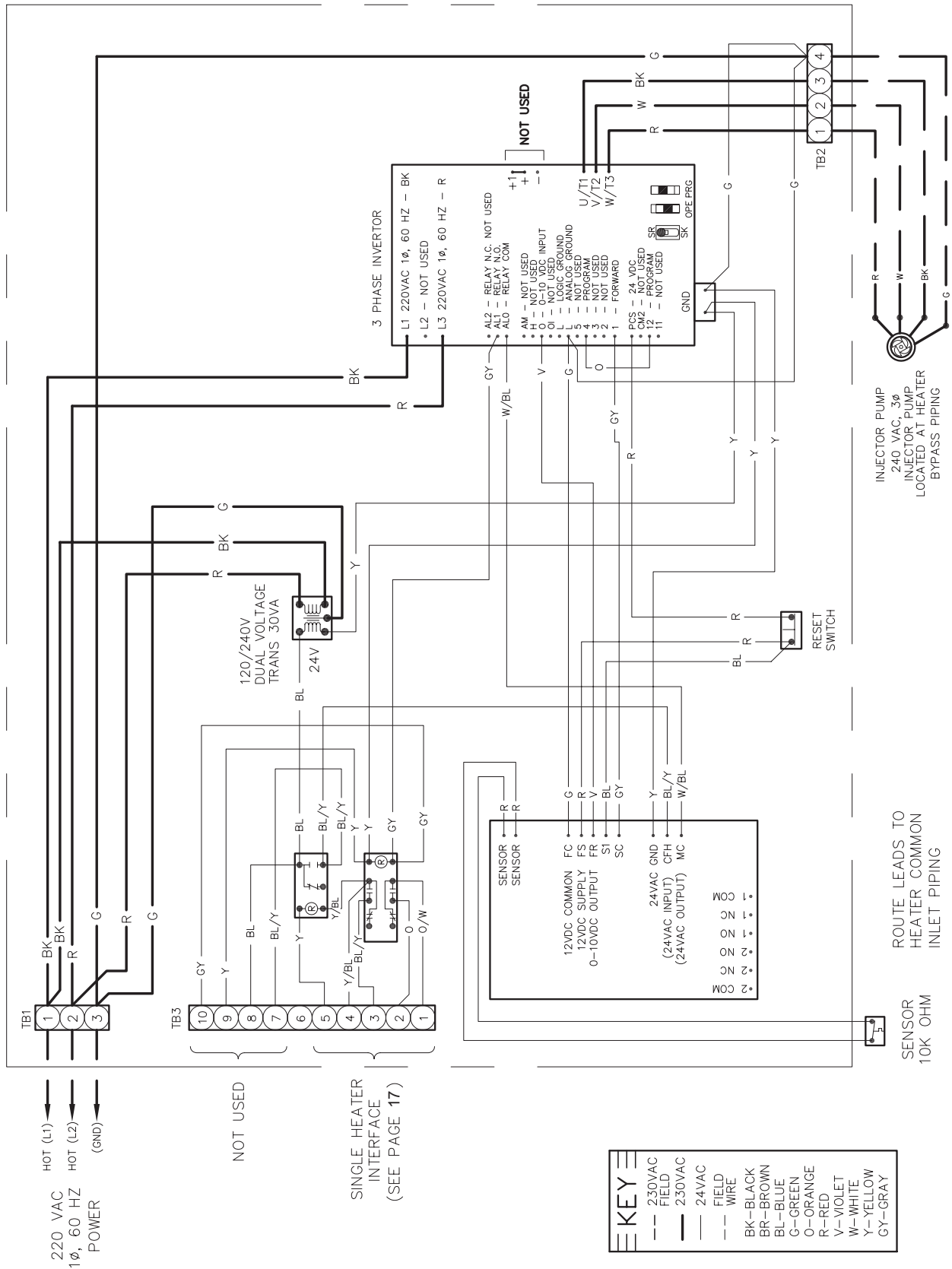

Wiring Diagram—Cold Water Run (AC Tech Inverter)

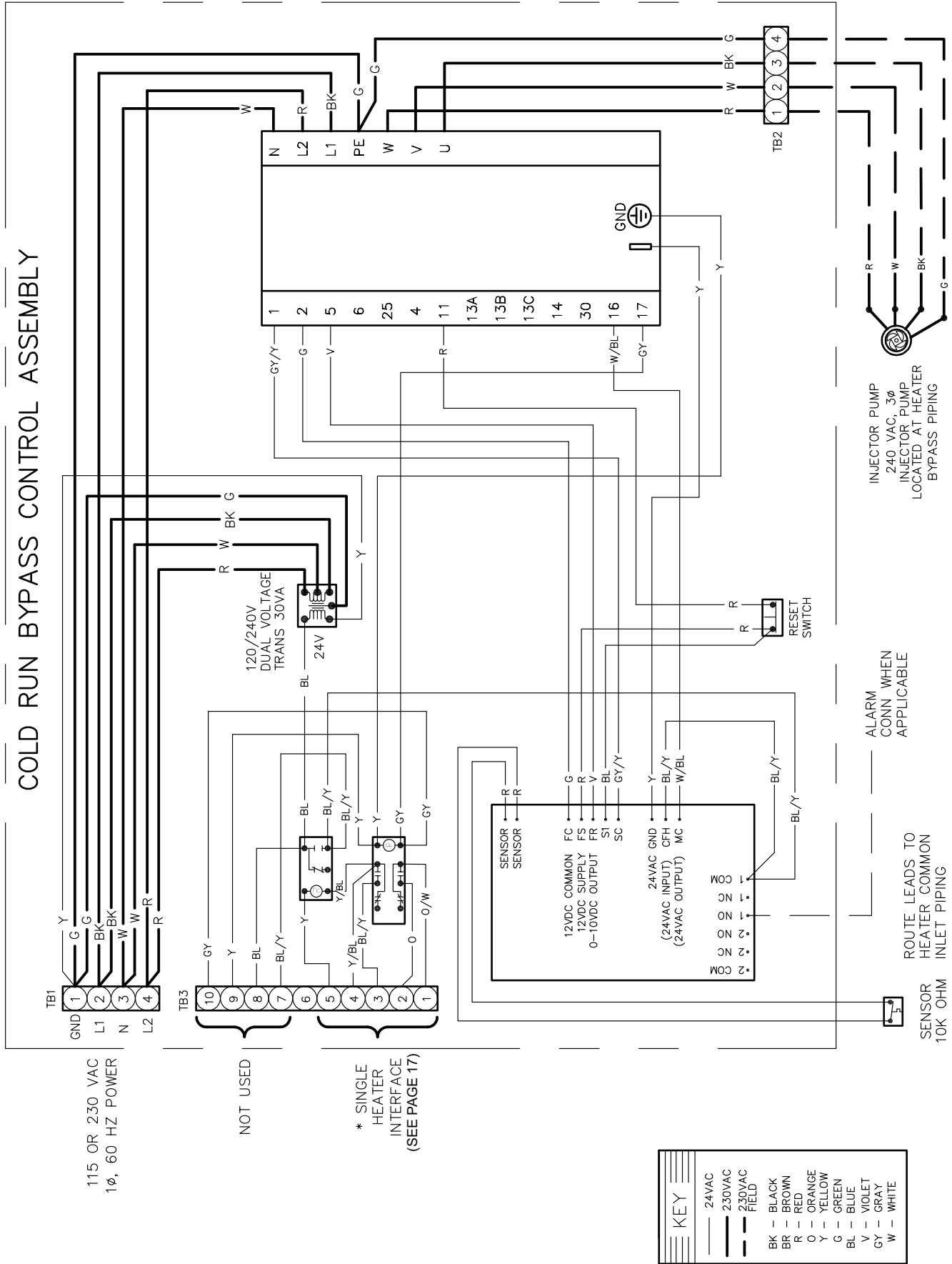

REPLACEMENT PARTS

To order replacement parts, consult the Raypak Illustrated Parts Lists 9300.82 for Cold Water Start and 9300.83 for Cold Water Run.

NOTE: To receive the correct part, it is important that you state the model number and serial number when ordering.

Any part returned for replacement under standard company warranties must be properly tagged with RAYPAK return parts tag, completely filled in with the heater serial number, model number, etc., and shipped to the Company freight prepaid. If determined defective by the Company and within warranty, the part will be returned in kind or equal substitution, freight collect. Credit will not be issued.

RAYPAK, INC.
2151 Eastman Avenue
Oxnard, CA 93030



www.raypak.com

Raypak, Inc., 2151 Eastman Avenue, Oxnard, CA 93030 (805) 278-5300 Fax (805) 278-5468
Litho in U.S.A.