



## DIVISION 23 52 33.13

### FINNED WATER-TUBE BOILERS

#### PART 1 - GENERAL

##### 1.1 SUMMARY

- A. Section includes gas-fired, copper finned-tube hydronic heating boilers
- B. Related Sections

*Specifier Note: Use as needed*

- 1. Building Services Piping – Division 23 21 00
- 2. Breeching, Chimneys, and Stacks (Venting) – Division 23 51 00
- 3. HVAC Instrumentation and Controls – Division 23 09 00
- 4. Electrical – Division 23 09 33

##### 1.2 REFERENCES

- A. ANSI Z21.13/CSA 4.9
- B. ASME, Section IV
- C. 2006 UMC, Section 1107.6
- D. ANSI/ASHRAE 15-1994, Section 8.13.6
- E. National Fuel Gas Code ANSI Z223.1/NFPA 54
- F. I=B=R
- G. NEC
- H. ASME CSD-1, 2006

##### 1.3 SUBMITTALS

- A. Product data sheet (including dimensions, rated capacities, shipping weights, accessories)
- B. Wiring diagram
- C. Warranty information
- D. Installation and operating instructions

##### 1.4 QUALITY ASSURANCE

- A. Regulatory Requirements
  - 1. ANSI Z21.13/CSA 4.9
  - 2. Local and national air quality regulations for low NOx (0-30 PPM NOx emissions) boilers
- B. Certifications
  - 1. CSA
  - 2. ASME H Stamp and National Board Listed
  - 3. ISO 9001

##### 1.5 WARRANTY

- A. Limited one-year warranty from date of installation
- B. Limited twenty-year thermal shock warranty
- C. Limited ten-year closed-system heat exchanger warranty

#### PART 2 - PRODUCTS

##### 2.1 MANUFACTURER

- A. Raypak, Inc.
  - 1. Contact: 2151 Eastman Ave., Oxnard, CA 93030; Telephone: (805) 278-5300;

Fax: (800) 872-9725; Web site: www.raypak.com

2. Product: Delta Limited™ copper finned-tube hydronic boiler(s)

## 2.2 BOILERS

### A. General

1. The boiler(s) shall be fired with \_\_\_\_\_ gas at a rated input of \_\_\_\_\_ BTU/hr.
2. The boiler(s) shall be CSA tested and certified with a minimum thermal efficiency of 84 percent at full fire.
3. The boiler(s) shall be ASME inspected and stamped and National Board registered for 160 PSIG working pressure, complete with a Manufacturer's Data Report.
4. The boiler(s) shall have a floor loading of 65 lbs. /square foot or less.

### B. Heat Exchanger

1. The heat exchanger shall be of a single-bank, horizontal-grid design with twelve integral copper finned tubes, each end of which is rolled into an ASME boiler-quality steel tube sheet.
2. The heat exchanger shall be sealed to 160 PSIG rated Cast Iron headers with silicone "O" rings, having a temperature rating over 500 °F.
3. The low water volume heat exchanger shall be explosion-proof on the water side and shall carry a twenty-year warranty against thermal shock.
4. The headers shall be secured to the tube sheet by stud bolts with flange nuts to permit inspection and maintenance without removal of external piping connections.
5. The boiler(s) shall be capable of operating at inlet water temperatures as low as 105 °F without condensation.
6. The boiler(s) shall be designed to accommodate field changes of either left or right hand plumbing and electrical while leaving the tube bundle in place.

### C. Burners

1. The tubular burners shall have multiport radial gas orifices, punched ports and slots, be capable of quiet ignition and extinction without flashback at the orifice, and be manufactured from corrosion resistant titanium-stabilized stainless steel with low expansion coefficient.
2. The burners will be supplied with a fan-assisted, clean burning, and highly efficient fuel-air mixture.

### D. Pilot Control System

1. The boiler(s) shall be equipped with a 100 percent safety shutdown system.
2. The ignition shall be Hot Surface Ignition type with full flame rectification by remote sensing separate from the ignition source, with a three-try-for-ignition sequence, to ensure consistent operation.
3. The igniter will be located away from the water inlet to protect the device from condensation during startup.
4. The ignition control module shall include an LED that indicates six (6) individual diagnostic flash codes.
5. Two external viewing ports shall be provided, permitting visual observation of burner operation.

### E. Gas Train

1. The boiler(s) shall have a firing/leak test valve and pressure test valve as required by CSD-1.
2. The boiler(s) shall have dual-seated main gas valve(s).
3. Gas control trains shall have a redundant safety shut-off feature, main gas regulator, shut-off cock and plugged pressure tapping to meet the requirements of ANSI Z21.13/CSA 4.9.

### F. Boiler Control

1. The following safety controls shall be provided:
  - a. High limit control
  - b. Flow switch, mounted and wired
  - c. \_\_\_\_\_PSIG ASME pressure relief valve, piped by the installer to an approved drain
  - d. Temperature and pressure gauge
2. The boiler(s) shall be equipped with a fixed five-minute energy-saving pump control relay,

mounted and wired, which automatically shuts off the boiler pump at a set period after boiler shut-down to avoid standby losses associated with constant pump operation.

G. Firing Mode

1. For model 989B, provide two-stage firing control of the gas input to the boiler.
2. For model 1259B, provide three-stage firing control of the gas input to the boiler.
3. For models 1529B – 2339B, provide four-stage control of the gas input to the boiler.

H. Boiler Diagnostics

1. Provide external LED panel displaying the following boiler status/faults:
  - a. Power on - Green
  - b. Call for heat – Amber
  - c. Burner on – Blue
  - d. Safety fault - Red
2. A Central Point Wiring board with diagnostic LED's indicating the status of each relay.
3. Provide ignition module indicating the following flash codes by LED signal:
  - a. 1 flash – low air pressure
  - b. 2 flashes – flame in the combustion chamber w/o CFH
  - c. 3 flashes – ignition lock-out (flame failure)
  - d. 4 flashes – low hot surface igniter current
  - e. 5 flashes – low 24VAC
  - f. 6 flashes – internal fault

I. Combustion Chamber: The lightweight, high temperature, multi-piece, interlocking ceramic fiber combustion chamber liner shall be sealed to reduce standby radiation losses, reducing jacket losses and increasing unit efficiency.

J. Venting

1. When routed vertically, the boiler's flue material and size shall be in accordance with the National Fuel Gas Code, ANSI Z223.1/NFPA54 latest edition (Category I).
2. When routed horizontally, the boiler(s) flue material and size shall meet or exceed the requirements as specified for Category III in the National Fuel Gas Code, ANSI Z223.1/NFPA 54 latest edition.
3. The boiler(s) shall be ducted combustion air ready.

K. Cabinet

1. The corrosion-resistant galvanized steel jackets shall be finished with a baked-on epoxy powder coat which is suitable for outdoor installation, applied prior to assembly for complete coverage, and shall incorporate louvers in the outer panels to divert air past heated surfaces.
2. The boiler(s), if located on a combustible floor, shall not require a separate combustible floor base.
3. The boiler(s) shall have the option of venting the flue products either through the top or the back of the unit.
4. Combustion air intake shall be on the left side of the cabinet, right side optional.

L. Operating Controls

1. The boiler(s) shall feature an optional multi-stage digital controller with adjustable outdoor reset, mounted and wired.
2. Water and air temperature sensors shall be shipped loose for field installation by installing contractor.

*Specifier Note: The remaining items in this section are options. Delete those that are not being specified. **IMPORTANT:** The Cold Water Start and Cold Water Run Systems cannot be used on the same boiler.*

M. Boiler Pump - Refer to Equipment Schedule

N. SureRack™ Boiler Stacking Kit

1. The boilers shall be stacked directly one on top of the other, without offset, to minimize footprint.

O. Cold Water Start System

1. The boiler(s) shall be configured with a cold water start automatic proportional by-pass system

that ensures the boiler will experience inlet temperatures in excess of 105°F in less than 7-minutes to avoid damaging condensation. The unit will automatically shut down if the inlet temperature is not achieved within the 7-minute time frame.

2. The cold water start system shall be configured with a modulating three-way valve that is controlled by a system-matched PID controller. The PID controller temperature sensor shall be located in the inlet header of the boiler.
3. The control shall have a temperature setting dial located on the face of the board. The temperature range of the dial shall be 105°F to 120°F. The PID Logic shall be capable of limiting system overshoot to a maximum of 10°F on initial start-up or call-for-heat.
4. The cold water start system shall be completely wired and mounted at the factory.
5. The control shall have the following diagnostic LED's:
  - a. Call for heat
  - b. Start-up mode
  - c. Inlet temperature error
  - d. Sensor out of range
6. The controller shall have the capability to add optional alarm contacts.

P. Cold Water Run System

1. The boiler(s) shall be configured with a cold water run automatic proportional by-pass system that ensures the boiler will experience inlet temperatures in excess of 105°F in less than 7 minutes to avoid damaging condensation. The unit will automatically shut down if the inlet temperature is not achieved within the 7-minute time frame.
2. The cold water run system shall be configured with a variable-speed pump that is controlled by a system-matched PID control that injects the correct amount of cold water directly into the boiler loop to maintain a minimum inlet temperature. The PID controller temperature sensor shall be located in the inlet header of the boiler.
3. The control shall have a temperature setting dial located on the face of the board. The temperature range of the dial shall be 105°F to 120°F. The PID Logic shall be capable of limiting system overshoot to a maximum of 10°F on initial start-up or call-for-heat.
4. The cold water start system shall be completely wired and mounted at the factory.
5. The control shall have the following diagnostic LED's:
  - a. Call for heat
  - b. Start-up mode
  - c. Inlet temperature error
  - d. Sensor out of range
6. The controller shall have the capability to add optional alarm contacts.

2.3 SOURCE QUALITY CONTROL

- A. The boiler(s) shall be completely assembled, wired, and fire-tested prior to shipment from the factory.
- B. The boiler(s) shall be furnished with the sales order, ASME Manufacturer's Data Report, inspection sheet, wiring diagram, rating plate and Installation and Operating Manual.

**PART 3 - EXECUTION**

3.1 INSTALLATION

- A. Must comply with
  1. Local, state, provincial, and national codes, laws, regulations and ordinances
  2. National Fuel Gas Code, ASNI Z223.1/NFPA 54 – latest edition
  3. National Electrical Code, ANSI/NFPA 70 – latest edition
  4. Standard for Controls and Safety Devices for Automatically Fired Boilers, ANSI/ASME CSD-1, when required
  5. Canada only: CAN/CSA B149 Installation Code and CSA C22.1 CEC Part I
  6. Manufacturer's installation instructions, including required service clearances and venting guidelines
- B. Manufacturer's representative to verify proper and complete installation.

### 3.2 START-UP

- A. Shall be performed by Raypak factory-trained personnel.
- B. Test during operation and adjust if necessary:
  - 1. Safeties (2.2 - F)
  - 2. Operating Controls (2.3)
  - 3. Static and full load gas supply pressure
  - 4. Gas manifold and blower air pressure
- C. Submit copy of start-up report to Architect and Engineer.

### 3.3 TRAINING

- A. Provide factory-authorized service representative to train maintenance personnel on procedures and schedules related to start-up, shut-down, trouble shooting, servicing, and preventive maintenance.
- B. Schedule training at least seven days in advance.

**END OF SECTION**

Job: \_\_\_\_\_

Engineer: \_\_\_\_\_

Contractor: \_\_\_\_\_

Prepared By: \_\_\_\_\_ Date: \_\_\_\_\_

Model: **H9-1529B** Indoor/Outdoor: \_\_\_\_\_ MBTUH Input: \_\_\_\_\_

# Delta Limited™ - Type H

## Space Heating/Hot Water Boiler Models 989B-2339B

- 100% Factory Fire Tested**
- Efficiency: 84%**
- Maximum Outlet Temperature: 230°F**
- Minimum Non-Condensing Inlet Temperature: 105°F**
- Thermal Shock Proof Heat Exchanger**
- Limited Twenty-Year Thermal Shock Warranty**
- Limited Ten-Year Closed-System Heat Exchanger Warranty**
- PolyTuf Powder Coated Cabinet**
- No Combustible Floor Shield Required**
- Fan-Assisted**
- Patented Burner Security Blanket**

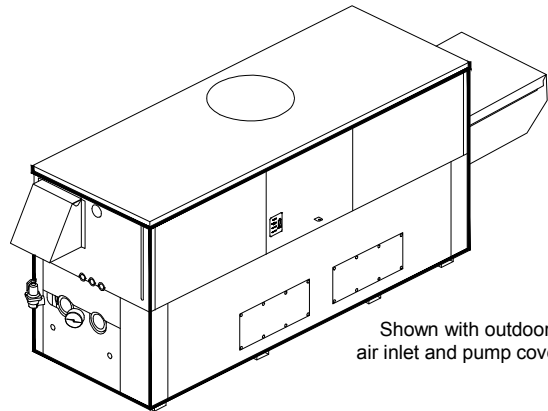

Shown with outdoor air inlet and pump covers



Proudly Made in the U.S.A.

### Heat Exchanger

- H Stamp
- Headers
  - Glass-Lined Cast Iron – Standard
  - Bronze – Option A-1
- ASME Inspected and Stamped  
160 PSIG Working Pressure
- National Board Approved
- Fin Tubing
  - Copper – Standard
  - Cupro Nickel – Option A-3
- ASME Steel Tube Sheet
- Silicone High Temp O-Rings
- ASME Pressure Relief Valve
  - 60 PSIG – Standard
  - 30 PSIG – Optional
- Temperature and Pressure Gauge
- Water Connections
  - Left – Standard
  - Right – Option A-6

### Controls

- 120V, 60Hz, 1 Phase Power Supply
- 120/24V 60Hz Transformer
- 100% Shut-Off/Lockout
- Hot Surface Ignition
- Remote Flame Sensor
- High Limit Control, Manual Reset
- On/Off Power Switch
- Manual Shut-Off, Front-Mounted Switch
- Flow Switch
- Blocked Vent Pressure Switch
- Combustion Air Proving Switch
- Pump Time Delay Relay
- Status Display Lights

### Gas Train

- Manual Gas Shut-Off Valve(s)
- Combination Valves
- Low Gas Pressure Switch, Manual
- Firing Stages
  - 2-Stage: Model 989B
  - 3-Stage: Model 1259B
  - 4-Stage: Models 1529B-2339B
- Fuel
  - Natural Gas
  - Propane Gas
- Design Certified - ANSI  
Z21.13/CSA 4.9

### Burner

- Ultra-Low NOx: Less than 20 PPM

### Construction

- Indoor/Outdoor Construction
- Enclosed Front Controls
- CSA Low Lead Certified ≤ .25 Pb

### Venting

- Vent Location
  - Top, Outdoor – Standard
  - Top, Indoor – Option D-20
  - Rear – Option D-14
- Vent Termination Cap
  - Outdoor D-11
  - Indoor, Horizontal D-15
  - Indoor, Vertical (by others)
- Extractor – Optional
  - By others
  - Not required

### Temperature Controls

- B-6 Aquastat, 2-Stage (100-200°F)
- B-\_\_ TempTracker Digital Controller, 2-Stage (Loose)
- B-\_\_ TempTracker Digital Controller, 4-Stage (Loose)
- B-\_\_ TempTracker Mod+ Hybrid (2-16 Boilers)
- B-60 Stage Interface

### Options

- C-6 Ignition Module, Manual Reset
- F-10 Low Water Cut-Off, Remote Probe
- I-1 High Limit Control, Auto Reset
- P-\_\_ Pump: \_\_\_\_\_ HP, 120V, 1∅, 60Hz
  - Cast Iron  Bronze
  - Mounted  Loose
  - Front  Rear
- P-\_\_ Cold Water Start (See 2000.48)
- S-2 High Gas Pressure Switch, Manual
- X-1 SureRack™ Kit
- X-2 SureRack Add-on

### Regulatory Agency Requirements

\_\_\_\_\_



Delta Limited models not approved for use in California

# Raupak®

A Rheem® Company

# Delta Limited – Type H Models 989B-2339B

Model \_\_\_\_\_

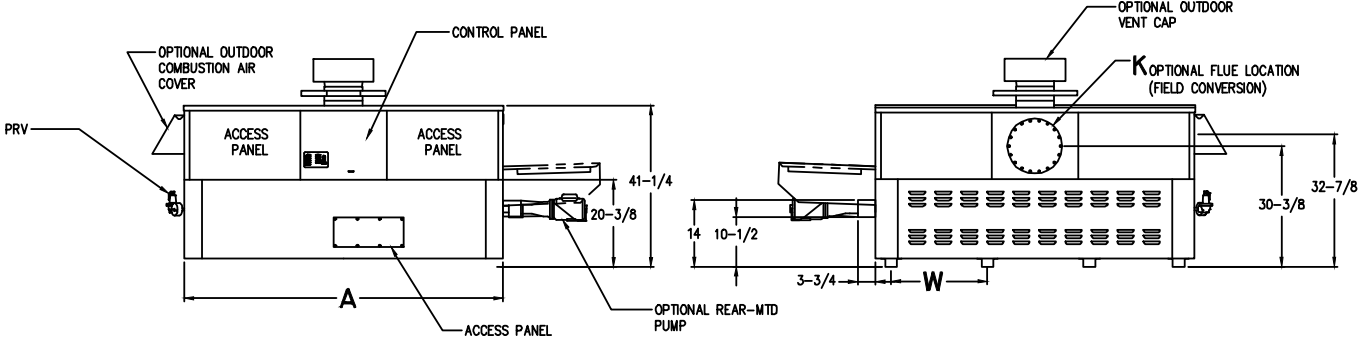

**FRONT VIEW**

**BACK VIEW**

NOTE:  
Pump location varies  
based on model selected

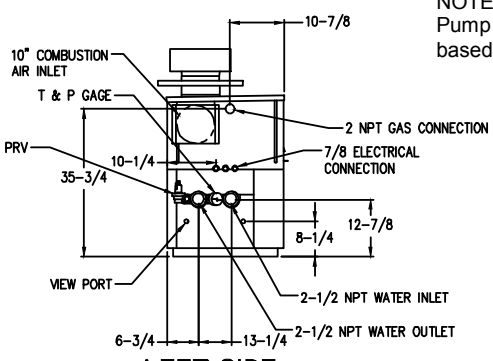

**LEFT SIDE**

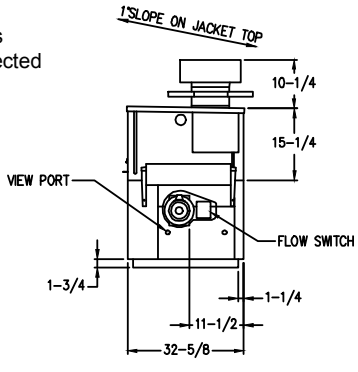

**RIGHT SIDE**

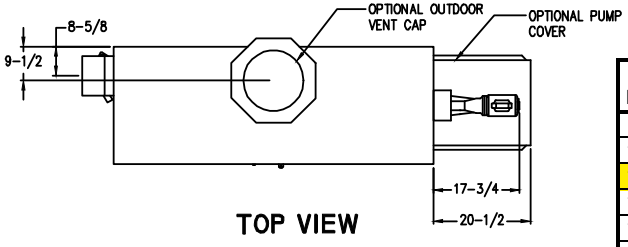

**TOP VIEW**

**RATES OF FLOW AND PRESSURE DROPS**

Model	20°F ΔT		30°F ΔT		Min. Flow			Max. Flow		
	GPM	ΔP (ft)	GPM	ΔP (ft)	GPM	ΔP (ft)	ΔT	GPM	ΔP (ft)	ΔT
989B	84	5.6	56	2.5	42	1.5	40	132	14.0	13
1259B	107	10.0	71	4.5	53	2.6	40	132	15.5	16
1529B	130	16.0	86	7.1	65	4.1	40	132	16.5	20
1799B	N/A	N/A	102	10.8	76	6.0	40	132	18.0	23
1999B	N/A	N/A	113	14.0	85	8.1	40	132	19.5	26
2069B	N/A	N/A	117	15.0	88	8.7	40	132	19.5	27
2339B	N/A	N/A	132	21.0	99	12.0	40	132	21.0	30

Basis is 40°F ΔT for minimum flow, 132 GPM for maximum flow.

**SPECIFICATIONS**

Model	MBTUH		Firing Stages	A Width	H NPT	K	W	Amp. Draw*	Approx. Shipping Wt. (Lbs.)
	Input	Output							
989B	990	832	2	57-1/8	2-1/2	10	16-13/16	< 12	900
1259B	1260	1058	3	68-1/2	2-1/2	12	20-9/16	< 12	1010
1529B	1530	1285	4	79-7/8	2-1/2	12	24-3/8	< 12	1225
1799B	1800	1512	4	91-1/8	2-1/2	14	28-1/8	< 12	1350
1999B**	1999	1679	4	102-1/2	2-1/2	14	31-15/16	< 12	1450
2069B	2070	1739	4	102-1/2	2-1/2	14	31-15/16	< 12	1450
2339B	2340	1966	4	113-7/8	2-1/2	16	35-11/16	< 12	1520

\* Pump not included

\*\* Natural Gas Only

Dimensions are in inches.

Rates shown are for natural or propane gas, and elevations up to 4,500 feet. For installation above 4,500 feet, please contact manufacturer.

Recommended natural gas supply pressure is 7 – 10.5" WC. Recommended propane gas supply pressure is 11 - 13" WC.