

## Combination valve



TM 04 7386 2010

**Fig. 1** Combination valve

### General information

A combination valve fitted between the discharge pipe and the discharge flange of a Grundfos pump gives the following advantages:

- The combination valve combines three valves in one: shut-off valve, balancing valve and check valve.
- The combination valve provides the feature of changing the flange orientation to allow 90 ° pipe connection.
- The combination valve makes it possible to reduce the overall system pressure drop since fewer individual components are needed when installing a pump.
- The combination valve is easy to dismantle and service. Internal parts, such as the disc can be easily removed and/or replaced.
- The combination valve has a built-in bypass valve allowing for drainage of water upstream of the check valve. (See Fig 3. and Fig 4.)  
The bypass valve **MUST** be **CLOSED** at all times in normal operation.  
The bypass valve should **ONLY** be used by authorized personel to drain water from the piping above.

### Combination valve range

Combination valves are available with ANSI 125 flanges and ANSI 250 flanges, see technical data below, and a variety of sizes ranging from 2 inches to 14 inches suction and discharge ports, see dimensional table.

### Technical data

	ANSI 125	ANSI 250
Pumped liquid	Water	Water
Max. pressure	175 psi	250 psi
Max. liquid temperature	150 °F	248 °F
Test pressure	265 psi	426 psi

#### Materials:

Upper body	ASTM A395 (ductile iron)	ASTM A395 (ductile iron)
	ASTM A126 Class B (cast iron)	
Lower body	ASTM A395 (ductile iron)	ASTM A395 (ductile iron)
	ASTM A126 Class B (cast iron)	
Stem	ASTM B124 C37700 (bronze)	ASTM A240-304 (stainless steel)
Hand wheel	ASTM A395 (ductile iron)	
	ASTM A395 (ductile iron)	
Disc	ASTM B124 C37700 (bronze)	
	ASTM A240- 304 (stainless steel)	
Soft seat	EPDM	
	ASTM B124 C37900 (bronze)	
Sleeve	ASTM B124 C37700 (bronze)	
Bush	ASTM B124 C37700 (bronze)	
Gland	ASTM B124 C37700 (bronze)	
Spring	ASTM A240-304 (stainless steel)	
Gasket	PTFE	
O-Ring	EPDM	
Disc ring	ASTM B584 C85400 (bronze)	
Disc bush	ASTM B124 C37700 (bronze)	
Bonnet	ASTM B124 C37700 (bronze)	
Disc packing	PTFE	

### Installation

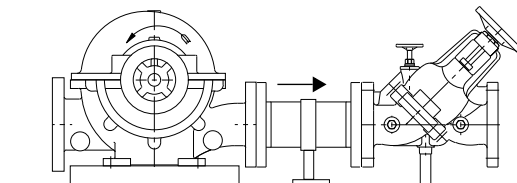

TM04 7387 2410

**Fig. 2** Pump installation with combination valve

# Accessories

## Sectional drawing and components

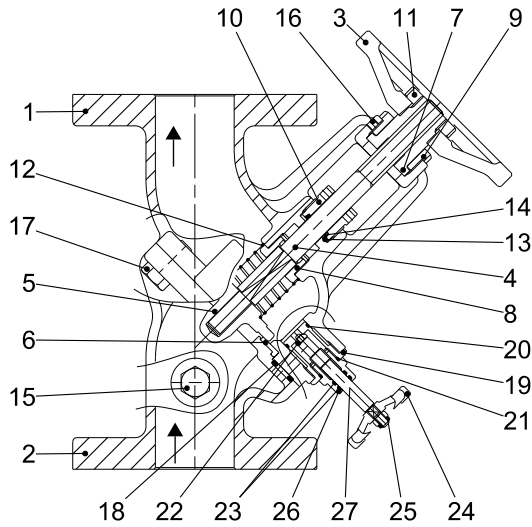

TM04 7916 2410

**Fig. 3** Sectional drawing of a combination valve  
2" to 8"

### Typical component list

Po no.	Description	Po no.	Description
1	Upper body	16	Socket set screw
2	Lower body	17	Bolt
3	Hand wheel	18	O-ring
4	Stem	19	Soft seat (bypass)
5	Disc	20	O-ring
6	Soft seat	21	O-ring
7	Sleeve (on shaft)	22	Disc packing
8	Bush	23	O-ring
9	Yoke nut (on shaft)	24	Hand wheel
10	Gland	25	Locknut
11	Hand wheel nut	26	Bonnet
12	Spring	27	Stem B
13	Gasket		
14	O-ring		
15	Plug		

Positions 20-27 cover the bypass valve only.  
2" to 8" valves.

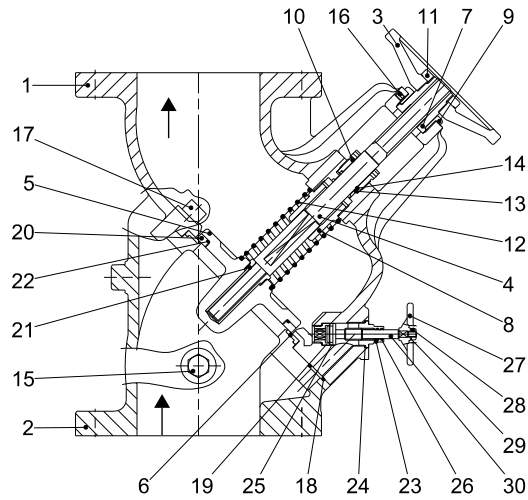

TM04 7388 2010

**Fig. 4** Sectional drawing of a combination valve  
10" to 14"

### Typical component list

Po no.	Description	Po no.	Description
1	Upper body	16	Socket set screw
2	Lower body	17	Wrench bolt
3	Hand wheel	18	O-ring
4	Stem	19	Soft seat (bypass)
5	Disc	20	Disc ring
6	Soft seat	21	Disc bush
7	Sleeve (on shaft)	22	O-ring
8	Bush	23	Bonnet
9	Yoke nut (on shaft)	24	O-ring
10	Gland	25	Disc packing
11	Hand wheel nut	26	O-ring
12	Spring	27	Hand wheel
13	Gasket	28	Nut
14	O-ring	29	Spring washer
15	Plug	30	Stem B

Positions 23-30 cover the bypass valve only.  
10" to 14" valves.

# Accessories

## Dimensions and weights- Straight Type

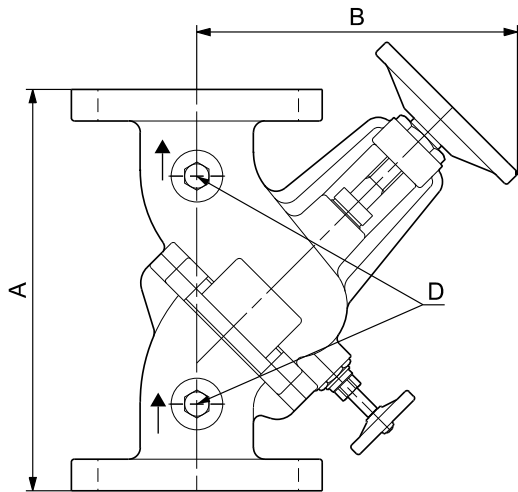

TM04 7917 2410

**Fig. 5** Dimensional drawing of a combination valve 2" to 8"

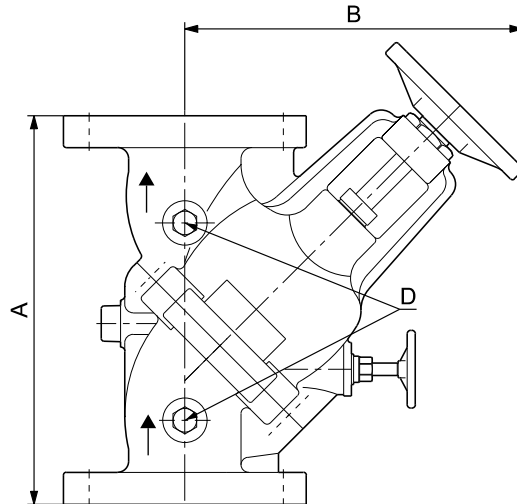

TM04 7389 2010

**Fig. 6** Dimensional drawing of a combination valve 10" to 14"

### ANSI 125

Inlet/outlet [inches]	Dimensions [inches]			Weight [lbs]
	A	B	D-NPT	
2 x 2	9.37	7.91	3/8	25
2.5 x 2.5	11.02	8.82	1/2	34
3 x 3	11.65	9.61	1/2	40
4 x 4	13.27	10.83	1/2	56
5 x 5	14.53	11.89	1/2	75
6 x 6	17.28	14.45	1/2	120
8 x 8	20.24	16.69	1/2	194
10 x 10	25.04	21.54	1/2	422
12 x 12	27.44	23.35	1/2	635
14 x 14	29.80	27.68	1/2	696

Dimensions shown are valve with open/close position.  
All dimension tolerances +/- .25".

### ANSI 250

Inlet/outlet [inches]	Dimensions [inches]			Weight [lbs]
	A	B	D-NPT	
2 x 2	9.37	7.91	3/8	25
2.5 x 2.5	11.02	8.82	1/2	34
3 x 3	11.65	9.61	1/2	40
4 x 4	13.27	10.83	1/2	56
5 x 5	14.53	11.89	1/2	75
6 x 6	17.28	14.45	1/2	120
8 x 8	20.24	16.69	1/2	194
10 x 10	26.42	21.54	1/2	422
12 x 12	28.94	23.35	1/2	635
14 x 14	31.30	27.68	1/2	696

Dimensions shown are valve with open/close position.  
All dimension tolerances +/- .25".

# Accessories

## Dimensions and weights- Angle Type

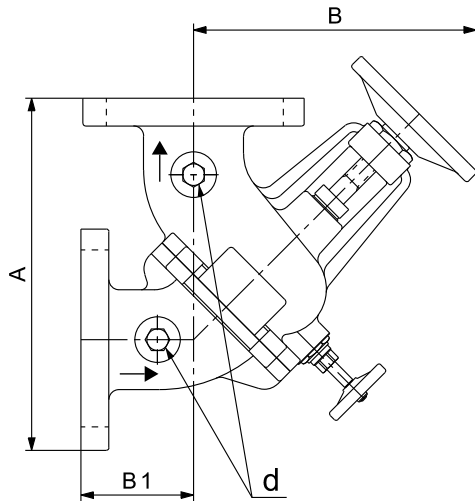

TM04 8103 3010

Fig. 7 Dimensional drawing of a combination valve 2" to 8"

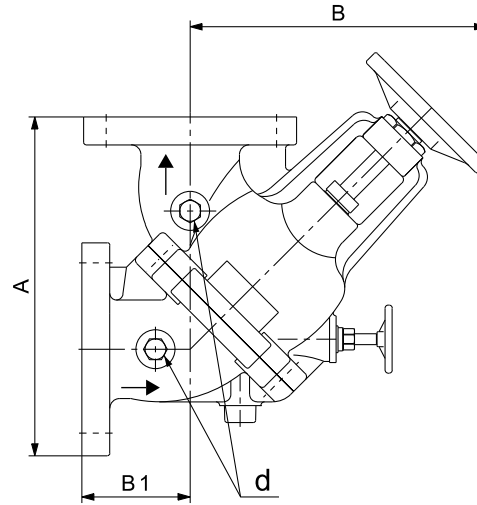

TM04 8104 3010

Fig. 8 Dimensional drawing of a combination valve 10" to 14"

### ANSI 125

Inlet/outlet [inches]	Dimensions [inches]				Weight [lbs]
	A	B	B1	D-NPT	
2 x 2	7.91	9.33	3.03	3/8	25
2.5 x 2.5	8.82	11.02	3.50	1/2	34
3 x 3	9.61	11.85	3.58	1/2	40
4 x 4	10.83	13.66	4.13	1/2	56
5 x 5	11.89	15.31	4.17	1/2	75
6 x 6	14.45	17.89	4.88	1/2	120
8 x 8	16.69	20.87	6.12	1/2	194
10 x 10	21.54	25.20	7.76	1/2	422
12 x 12	23.35	28.41	8.50	1/2	635
14 x 14	27.68	31.87	8.54	1/2	696

Dimensions shown are valve with open/close position.  
All dimension tolerances +/- .25".

### ANSI 250

Inlet/outlet [inches]	Dimensions [inches]				Weight [lbs]
	A	B	B1	D-NPT	
2 x 2	7.91	9.33	3.03	3/8	25
2.5 x 2.5	8.82	11.02	3.50	1/2	34
3 x 3	9.61	11.85	3.58	1/2	40
4 x 4	10.83	13.66	4.13	1/2	56
5 x 5	11.89	15.31	4.17	1/2	75
6 x 6	14.45	17.89	4.88	1/2	120
8 x 8	16.69	20.87	6.12	1/2	194
10 x 10	21.54	25.20	7.76	1/2	422
12 x 12	23.35	28.41	8.50	1/2	635
14 x 14	27.68	31.87	8.54	1/2	696

Dimensions shown are valve with open/close position.  
All dimension tolerances +/- .25".

# Accessories

## Part numbers

Combination valves can be ordered using these part numbers.

Straight type valve shipped from factory only. See IOM for conversion to angle type valve.

Inlet/outlet [inches]	ANSI 125		ANSI 250	
	Reference No.	Part No.	Reference No.	Part No.
2 x 2	CV20-125	97523122	CV20-250	97523104
2.5 x 2.5	CV25-125	97523123	CV25-250	97523105
3 x 3	CV30-125	96877844	CV30-250	97523106
4 x 4	CV40-125	96877845	CV40-250	97523107
5 x 5	CV50-125	97523124	CV50-250	97523108
6 x 6	CV60-125	96877846	CV60-250	97523109
8 x 8	CV80-125	96877847	CV80-250	97523141
10 x 10	CV10-125	97523125	CV10-250	97523142
12 x 12	CV12-125	97523126	CV12-250	97523143
14 x 14	CV14-125	97523127	CV14-250	97523144

NOTE: Use part no. to order the combination valve.  
250# flanges are available upon request with 14 weeks delivery.

## Pressure drop

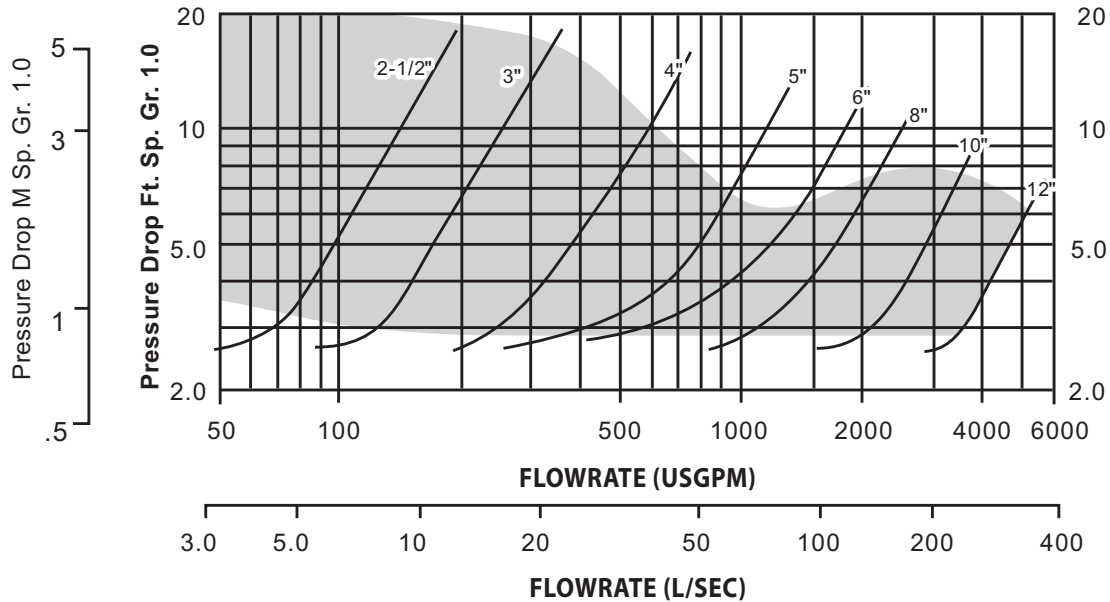

Fig. 9 Pressure drop graph for combination valves.  
Valve in full open position. Size valves in shaded area only.

TM04 7390 2010

## MODEL SG SUCTION GUIDES | SUBMITTAL

File No: 35.52  
 Date: SEPT. 03, 2013  
 Supersedes: 35.52  
 Date: MAY 16, 2013

Job: \_\_\_\_\_ Representative: \_\_\_\_\_  
 \_\_\_\_\_ Ordered by: \_\_\_\_\_ Date: \_\_\_\_\_  
 Engineer: \_\_\_\_\_ Submitted by: \_\_\_\_\_ Date: \_\_\_\_\_  
 Contractor: \_\_\_\_\_ Approved by: \_\_\_\_\_ Date: \_\_\_\_\_

MODEL NUMBER	CONNECTION SIZES ANSI 125 FLANGED		QUANTITY REQUIRED	IDENTIFICATION
	INLET FROM SYSTEM NPTF	OUTLET TO PUMP		

### MAXIMUM PUMP OPERATING CONDITIONS

#### ANSI 125

175 psig at 230°F (12 bar at 110°C)

### MATERIALS OF CONSTRUCTION

- Body:** Cast iron
- Strainer:** Stainless steel, 0.125" (3 mm) perf.
- Start-up strainer:** Fine mesh galvanized steel  
(remove after 1 week)
- Guide vanes:** Cast iron
- Inlet gauge tapping:** 1/4" NPT - plugged

### PRESSURE TEMPERATURE LIMITS

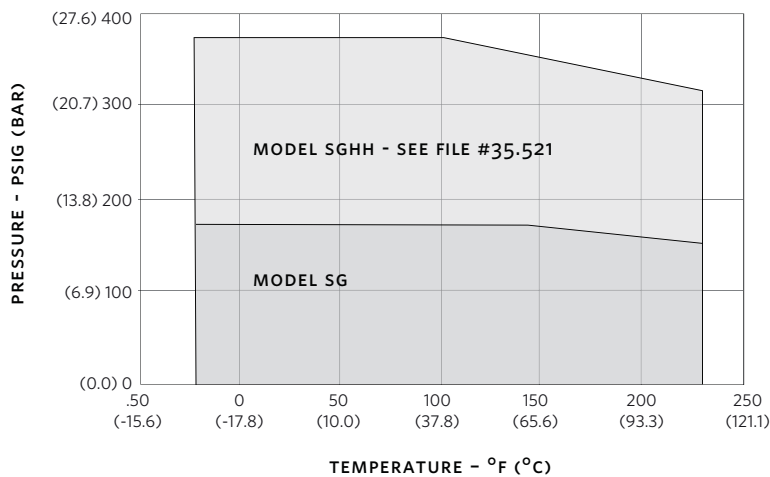

### OPTIONS

PRESSURE DROP - FT (M) OF WATER @ FLOW IN USGPM (L/S)							
MODEL	VELOCITY - FT/S (M/S)						
	3 (0.91)	4 (1.22)	5 (1.52)	6 (1.83)	8 (2.44)	10 (3.05)	12 (3.66)
SG-22							
SG-252	0.11 (0.03) @ 32 (2.0)	0.20 (0.06) @ 43 (2.7)	0.32 (0.10) @ 54 (3.4)	0.32 (0.10) @ 54 (3.4)	0.80 (0.25) @ 86 (5.4)	0.80 (0.25) @ 86 (5.4)	1.72 (0.54) @ 128 (8.1)
SG-32							
SG-2525	0.18 (0.05) @ 45 (2.8)	0.32 (0.10) @ 50 (3.2)	0.50 (0.15) @ 75 (4.7)	0.72 (0.22) @ 90 (5.7)	1.28 (0.39) @ 120 (7.6)	2.00 (0.61) @ 150 (9.5)	2.88 (0.88) @ 180 (11.4)
SG-325							
SG-33	0.20 (0.06) @ 70 (4.4)	0.35 (0.11) @ 92 (5.8)	0.55 (0.17) @ 115 (7.3)	0.55 (0.17) @ 115 (7.3)	1.42 (0.43) @ 1.42 (0.43)	2.20 (0.67) @ 230 (14.5)	3.15 (0.96) @ 276 (17.4)
SG-43							
SG-44							
SG-54	0.17 (0.05) @ 118 (7.4)	0.29 (0.09) @ 155 (9.8)	0.29 (0.09) @ 155 (9.8)	0.68 (0.21) @ 238 (15.0)	1.20 (0.37) @ 315 (19.9)	1.90 (0.58) @ 396 (25.0)	2.75 (0.84) @ 475 (30.0)
SG-64							
SG-55	0.23 (0.07) @ 187 (11.8)	0.41 (0.13) @ 250 (15.8)	0.67 (0.20) @ 315 (19.9)	0.95 (0.29) @ 375 (23.7)	1.70 (0.52) @ 500 (31.5)	2.65 (0.81) @ 625 (39.4)	2.65 (0.81) @ 625 (39.4)
SG-65							
SG-66	2.65 (0.81) @ 625 (39.4)	0.38 (0.12) @ 360 (22.7)	0.60 (0.18) @ 450 (28.4)	0.86 (0.26) @ 540 (34.1)	1.54 (0.47) @ 720 (45.4)	2.40 (0.73) @ 900 (56.8)	3.45 (1.05) @ 1080 (68.1)
SG-86							
SG-88	0.21 (0.06) @ 470 (29.7)	0.37 (0.11) @ 625 (39.4)	0.58 (0.18) @ 780 (49.2)	0.85 (0.26) @ 940 (59.3)	1.50 (0.46) @ 1250 (78.9)	2.30 (0.70) @ 1550 (97.8)	3.35 (1.02) @ 1870 (118.0)
SG-108							
SG-1010	0.26 (0.08) @ 740 (46.7)	0.46 (0.14) @ 980 (61.8)	0.73 (0.22) @ 1230 (77.6)	1.03 (0.31) @ 1480 (93.4)	1.85 (0.56) @ 1960 (123.7)	2.92 (0.89) @ 2450 (154.6)	4.20 (1.28) @ 2940 (185.5)
SG-1210							
SG-1212	0.25 (0.08) @ 1080 (68.1)	0.44 (0.13) @ 1400 (88.3)	0.72 (0.22) @ 1750 (110.4)	1.02 (0.31) @ 2100 (132.5)	1.81 (0.55) @ 2800 (176.7)	2.80 (0.85) @ 3500 (220.8)	4.00 (1.22) @ 4200 (265.0)
SG-1412							

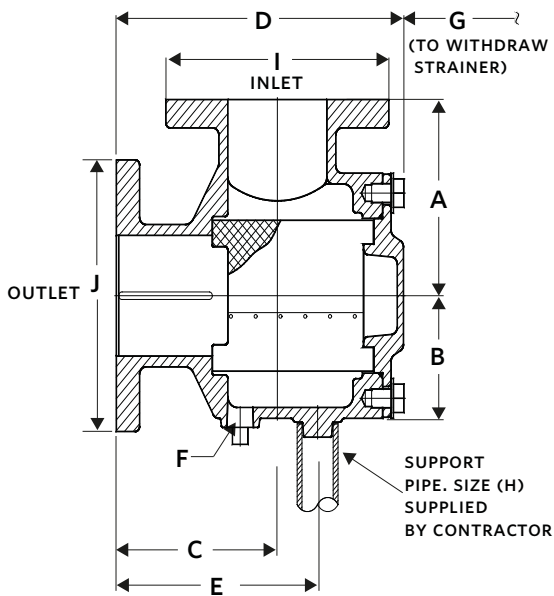

Companion flanges not included.

DIMENSIONAL DATA SG														
MODEL	CONNECTION SIZE		STRAINER FREE AREA in <sup>2</sup> (cm <sup>2</sup> )	DIMENSIONS IN INCHES (MM)										WEIGHT lbs (kg)
	SYSTEM	PUMP		A	B	C	D	E	F	G	H	I	J	
SG-22	2 (51)	2 (51)	34 (222)	4.50 (114)	3.07 (78)	4.50 (114)	8.50 (216)	5.71 (145)	0.50 (13)	4.75 (121)	1.00 (25)	6.00 (152)	6.00 (152)	26 (11.8)
SG-252	2.5 (64)	2 (51)	34 (222)	5.00 (127)	3.07 (78)	4.50 (114)	8.50 (216)	5.71 (145)	0.50 (13)	4.75 (121)	1.00 (25)	7.00 (178)	6.00 (152)	29 (13.2)
SG-32	3 (76)	2 (51)	34 (222)	5.50 (140)	3.07 (78)	4.50 (114)	8.50 (216)	5.71 (145)	0.50 (13)	4.75 (121)	1.00 (25)	7.50 (191)	6.00 (152)	31 (14.1)
SG-2525	2.5 (64)	2.5 (64)	34 (222)	4.90 (124)	3.07 (78)	4.90 (124)	7.50 (191)	5.86 (149)	0.50 (13)	4.75 (121)	1.00 (25)	7.12 (181)	7.12 (181)	34 (15.4)
SG-325	3 (76)	2.5 (64)	34 (222)	5.50 (140)	3.07 (78)	4.90 (124)	7.50 (191)	5.86 (149)	0.50 (13)	4.75 (121)	1.00 (25)	7.50 (191)	7.12 (181)	35 (15.9)
SG-33	3 (76)	3 (76)	44 (282)	5.40 (137)	3.63 (92)	5.40 (137)	9.88 (251)	7.00 (178)	0.75 (19)	5.50 (140)	1.00 (25)	7.81 (198)	7.81 (198)	45 (20.4)
SG-43	4 (102)	3 (76)	44 (282)	6.50 (165)	3.63 (92)	5.90 (150)	10.38 (264)	7.50 (191)	0.75 (19)	5.50 (140)	1.00 (25)	9.00 (229)	7.81 (198)	53 (24.0)
SG-44	4 (102)	4 (102)	79 (511)	6.50 (165)	4.19 (106)	6.50 (165)	11.75 (298)	8.13 (206)	0.75 (19)	7.00 (178)	1.25 (32)	9.00 (229)	9.00 (229)	72 (32.7)
SG-54	5 (127)	4 (102)	79 (511)	7.44 (189)	4.19 (106)	6.50 (165)	11.75 (298)	8.13 (206)	0.75 (19)	7.00 (178)	1.25 (32)	10.00 (254)	9.00 (229)	79 (35.8)
SG-64	6 (152)	4 (102)	79 (511)	8.03 (204)	4.19 (106)	7.50 (191)	12.75 (324)	9.13 (232)	0.75 (19)	7.00 (178)	1.25 (32)	11.00 (279)	9.00 (229)	87 (39.5)
SG-55	5 (127)	5 (127)	111 (719)	7.47 (190)	4.81 (122)	7.47 (190)	13.50 (343)	9.47 (241)	1.00 (25)	8.00 (203)	1.25 (32)	10.00 (254)	10.00 (254)	99 (44.9)
SG-65	6 (152)	5 (127)	111 (719)	8.00 (203)	4.81 (122)	7.47 (190)	13.50 (343)	9.47 (241)	1.00 (25)	8.00 (203)	1.25 (32)	11.15 (283)	10.00 (254)	103 (46.7)
SG-66	6 (152)	6 (152)	120 (775)	8.00 (203)	5.71 (145)	8.00 (203)	14.75 (375)	10.19 (259)	1.00 (25)	9.25 (235)	2.00 (51)	11.15 (283)	11.15 (283)	141 (63.9)
SG-86	8 (203)	6 (152)	120 (775)	9.00 (229)	5.71 (145)	10.00 (254)	16.75 (425)	12.19 (310)	1.00 (25)	9.25 (235)	2.00 (51)	13.50 (343)	11.15 (283)	180 (81.6)
SG-88	8 (203)	8 (203)	273 (1760)	8.93 (227)	7.00 (178)	10.28 (261)	18.75 (476)	13.42 (341)	1.00 (25)	12.25 (311)	2.00 (51)	13.50 (343)	13.50 (343)	213 (96.6)
SG-108	10 (254)	8 (203)	273 (1760)	10.93 (278)	7.00 (178)	12.78 (325)	21.25 (540)	15.92 (404)	1.00 (25)	12.25 (311)	2.00 (51)	16.00 (406)	13.50 (343)	246 (111.6)
SG-1010	10 (254)	10 (254)	538 (3474)	11.43 (290)	8.13 (207)	12.72 (323)	23.25 (591)	16.85 (428)	1.00 (25)	15.00 (381)	2.00 (51)	16.00 (406)	16.00 (406)	349 (158.3)
SG-1210	12 (305)	10 (254)	538 (3474)	13.00 (330)	8.13 (207)	15.72 (399)	26.25 (667)	19.85 (504)	1.00 (25)	15.00 (381)	2.00 (51)	19.00 (483)	16.00 (406)	390 (176.9)
SG-1212	12 (305)	12 (305)	753 (4861)	15.30 (389)	10.76 (273)	14.18 (360)	27.50 (699)	20.45 (519)	1.00 (25)	19.00 (483)	2.00 (51)	19.00 (483)	19.00 (483)	641 (290.7)
SG-1412	14 (356)	12 (305)	753 (4861)	16.00 (406)	10.76 (273)	14.18 (360)	27.50 (699)	20.45 (519)	1.00 (25)	19.00 (483)	2.00 (51)	21.00 (533)	19.00 (483)	637 (288.9)

Dimensions and weights are for reference only. Dimensions are inches (mm) and weights are lbs (kg).



**TORONTO**

23 BERTRAND AVENUE  
TORONTO, ONTARIO  
CANADA  
M1L 2P3  
+1 416 755 2291

**BUFFALO**

93 EAST AVENUE  
NORTH TONAWANDA, NEW YORK  
U.S.A.  
14120-6594  
+1 716 693 8813

**BIRMINGHAM**

HEYWOOD WHARF, MUCKLOW HILL  
HALESOWEN, WEST MIDLANDS  
UNITED KINGDOM  
B62 8DJ  
+44 (0) 8444 145 145

**MANCHESTER**

WENLOCK WAY  
MANCHESTER  
UNITED KINGDOM  
M12 5JL  
+44 (0) 8444 145 145

**BANGALORE**

#59, FIRST FLOOR, 3RD MAIN  
MARGOSA ROAD, MALLESWARAM  
BANGALORE, INDIA  
560 003  
+91 (0) 80 4906 3555

**SHANGHAI**

NO. 1619 HU HANG ROAD, XI DU TOWNSHIP  
FENG XIAN DISTRICT, SHANGHAI  
P.R.C.  
201401  
+86 21 3756 6696

ARMSTRONG FLUID TECHNOLOGY  
ESTABLISHED 1934

ARMSTRONGFLUIDTECHNOLOGY.COM

**MAKING  
ENERGY  
MAKE  
SENSE™**