



Position	Count	Description	Unitprice
	-1	<p><b>UPS 43-100</b></p>  <p>Product photo could vary from the actual product</p> <p>Product No.: 95906636                      The pump is of the canned rotor type, i.e. pump and motor form an integral unit without shaft seal and with only two gaskets for sealing. The bearings are lubricated by the pumped liquid. The pump is characterized by:</p> <ul style="list-style-type: none"> <li>* Ceramic shaft and radial bearings.</li> <li>* Carbon axial bearing.</li> <li>* Stainless steel rotor can and bearing plate.</li> <li>* Corrosion-resistant impeller, Composite, PES.</li> <li>* Cast iron pump housing.</li> </ul> <p>The motor is a 1-phase motor.                      No additional motor protection is required.</p> <p><b>Liquid:</b>                      Liquid temperature range: 32 .. 230 °F                      Density: 62.4 lb/ft³</p> <p><b>Technical:</b>                      Maximum operating pressure: 145 psi                      Approvals on nameplate: ETL, CSA</p> <p><b>Materials:</b>                      Pump housing: Cast iron                      EN-GJL-200                      Impeller: Composite, PES</p> <p><b>Installation:</b>                      Maximum ambient temperature: 104 °F                      Ambient max at 176°F liquid: 176 °F                      Maximum operating pressure: 145 psi                      Flange standard: USA Oval                      Type of connection: C.I. Flange                      Pipe connection: 2 - Bolt Flange                      Pressure stage: 10</p>	On request



Company name: -  
 Created by: -  
 Phone: -  
 Fax: -  
 Date: -

Position	Count	Description	Unitprice
		Port-to-port length: 8 1/2 in  <b>Electrical data:</b> Number of poles: 2 Power input in speed 1: 265 W Power input in speed 2: 335 W Max. power input: 370 W Rated power - P2: 0.335 HP Main frequency: 60 Hz Rated voltage: 1 x 115 V Current in speed 1: 2.5 A Current in speed 2: 3.1 A Current in speed 3: 3.5 A Capacitor size - run: 40 µF/180 V Insulation class (IEC 85): H  <b>Others:</b> Gross weight: 18.5 lb	

Description	Value
Product name:	UPS 43-100 F
Product Number:	95906636
EAN number:	5700313291748
<b>Technical:</b>	
Speed Number:	3
Max flow:	65 US gpm
Head max:	30.8 ft
Maximum operating pressure:	145 psi
Approvals on nameplate:	ETL, CSA
<b>Materials:</b>	
Pump housing:	Cast iron EN-GJL-200
Impeller:	Composite, PES
<b>Installation:</b>	
Maximum ambient temperature:	104 °F
Ambient max at 176°F liquid:	176 °F
Maximum operating pressure:	145 psi
Flange standard:	USA Oval
Type of connection:	C.I. Flange
Pipe connection:	2 - Bolt Flange
Pressure stage:	10
Port-to-port length:	8 1/2 in
<b>Liquid:</b>	
Liquid temperature range:	32 .. 230 °F
Density:	62.4 lb/ft³
<b>Electrical data:</b>	
Number of poles:	2
Power input in speed 1:	265 W
Power input in speed 2:	335 W
Max. power input:	370 W
Rated power - P2:	0.335 HP
Main frequency:	60 Hz
Rated voltage:	1 x 115 V
Current in speed 1:	2.5 A
Current in speed 2:	3.1 A
Current in speed 3:	3.5 A
Capacitor size - run:	40 µF/180 V
Insulation class (IEC 85):	H
Motor protection:	CONTACT
Thermal protec:	internal
<b>Controls:</b>	
Pos term box:	9H
<b>Others:</b>	
Gross weight:	18.5 lb

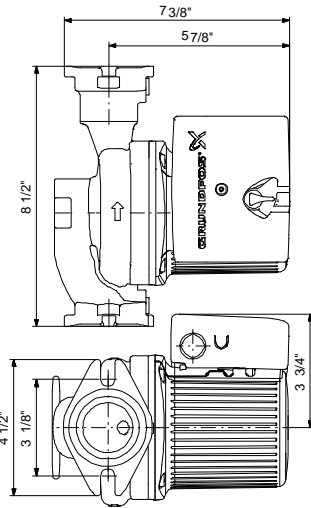
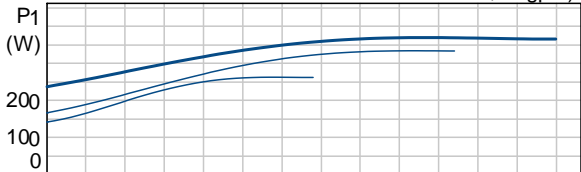
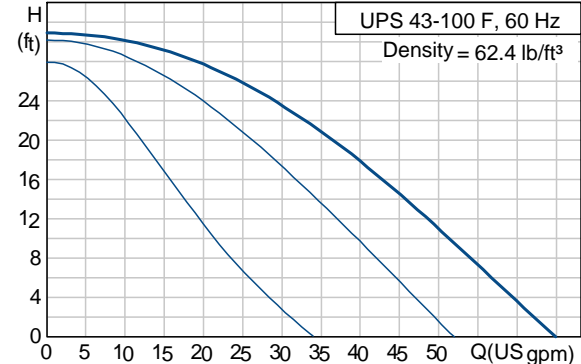

95906636 UPS 43-100 F 60 Hz

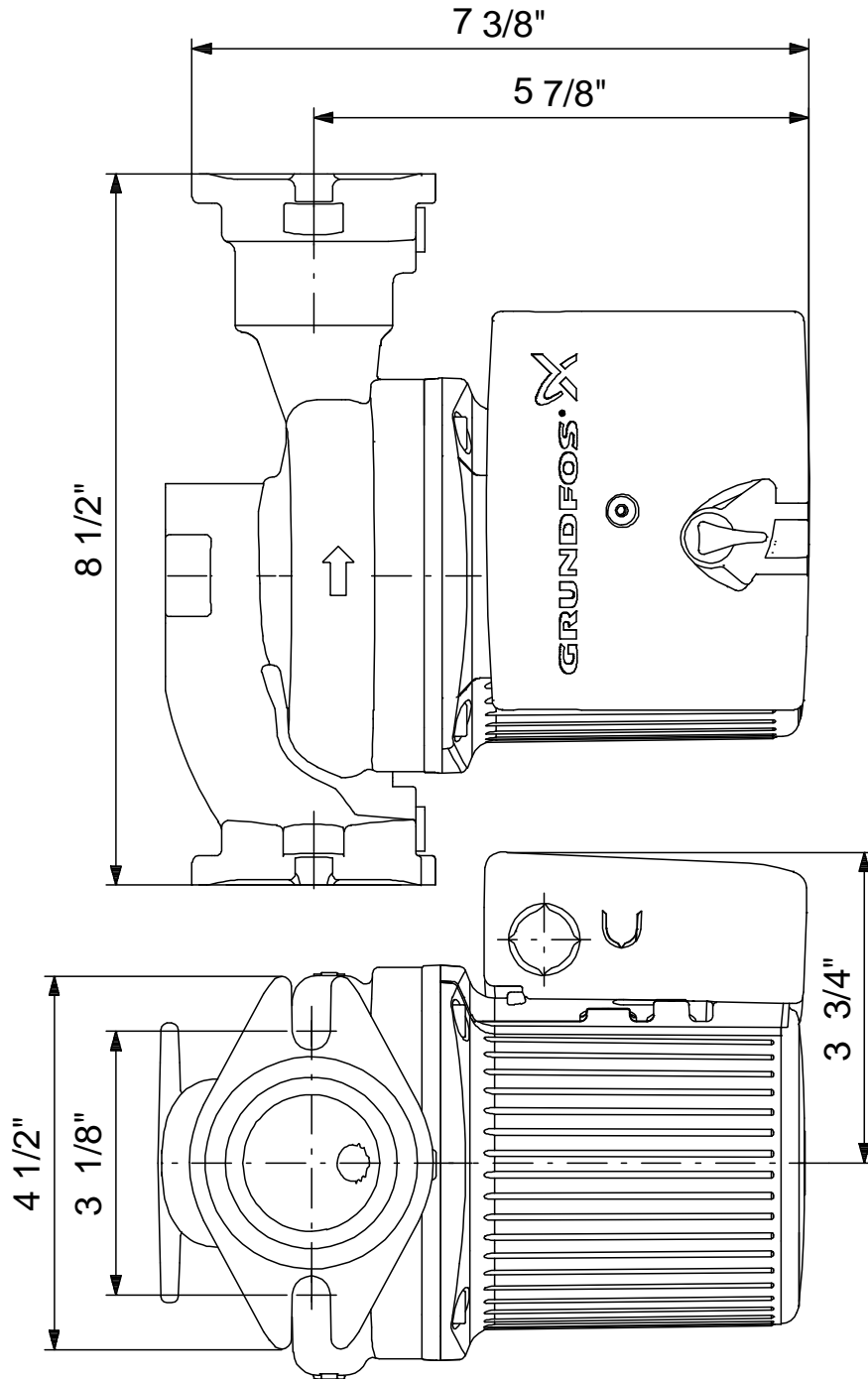

Note! All units are in [mm] unless others are stated.  
Disclaimer: This simplified dimensional drawing does not show all details.

# CR, CRI, CRN, CRE, CRIE, CRNE

Vertical multistage centrifugal pumps  
60 Hz

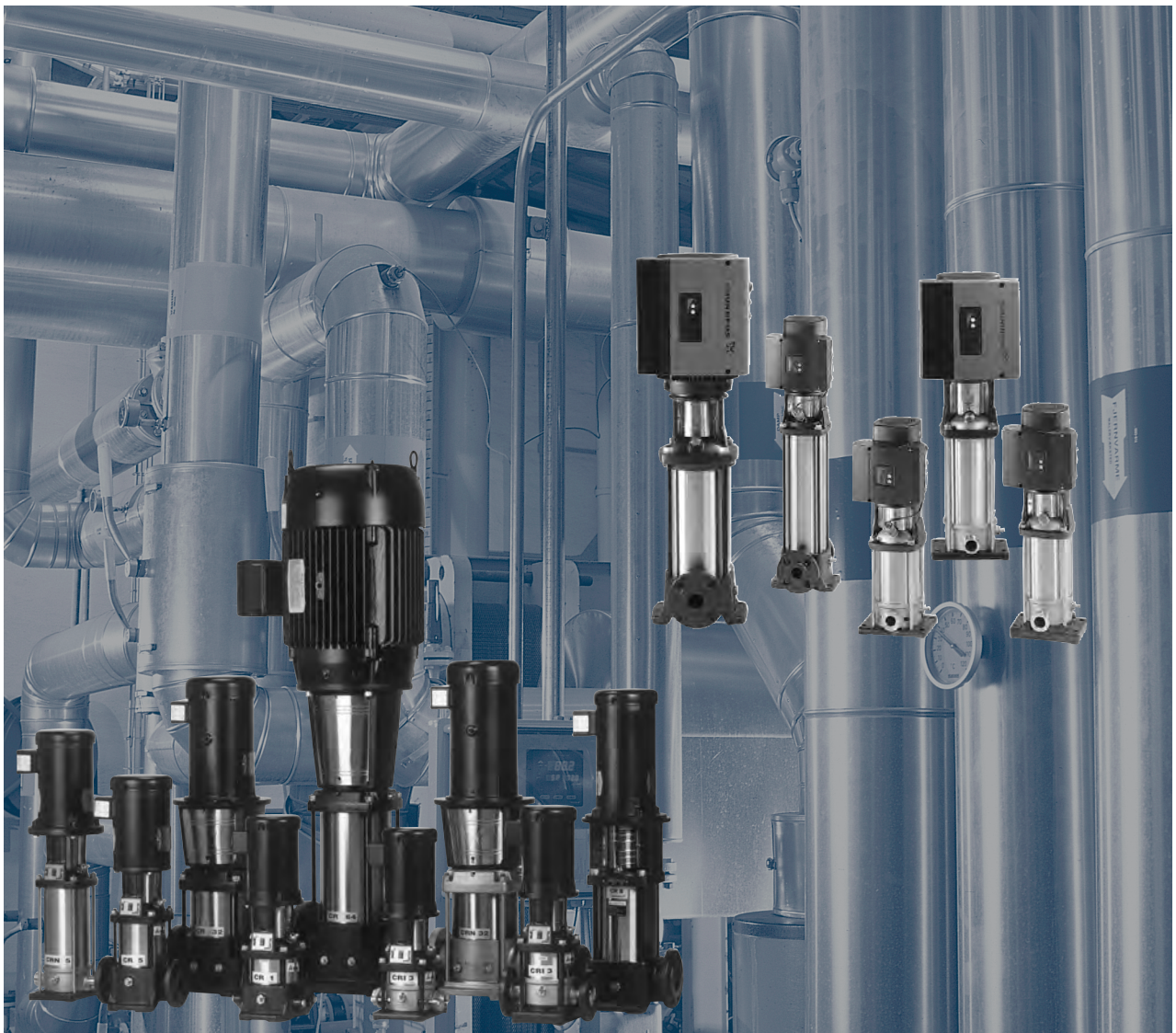

# Contents

## Mission

## Product overview

Introduction	4
Product range	6
Applications	8
Pump	9
Motor	9
Terminal box positions	10
Ambient temperature	10
Viscosity	10

## Product overview for E-pumps

Examples of E-pump applications	11
---------------------------------	----

## Control of E-pumps

Control options of E-pumps	12
Control modes for E-pumps	12

## Construction

CR(E) 1s, 1, 3, 5, 10, 15 and 20	14
CRI(E), CRN(E) 1s, 1, 3, 5, 10, 15 and 20	14
CR(E) 32, 45, 64 and 90	15
CRN(E) 32, 45, 64 and 90	15
CR(E) 120 and 150	16
CRN(E) 120 and 150	16

## Type keys and codes

Type keys	17
Codes	17

## Operating and inlet pressure

Maximum operating pressure and temperature range	18
Operating range of the shaft seal	19
Maximum inlet pressure	20

## Selection and sizing

Selection of pumps	21
How to read the curve charts	25
Guidelines to performance curves	25

## Performance curves/

## Technical data

CR, CRI, CRN 1s	26
CR(E), CRI(E), CRN(E) 1	30
CR(E), CRI(E), CRN(E) 3	34

CR(E), CRI(E), CRN(E) 5	38
CR(E), CRI(E), CRN(E) 10	42
CR(E), CRI(E), CRN(E) 15	46
CR(E), CRI(E), CRN(E) 20	50
CR(E), CRN(E) 32	54
CR(E), CRN(E) 45	57
CR(E), CRN(E) 64	60
CR, CRN 90	63
CR, CRN 120	66
CR, CRN 150	69

## Motor data

Standard motors in the CR range	72
TEFC motors	72
ODP motors	73
2 Pole MLE motors	73

## Pumped liquids

Pumped liquids	74
List of pumped liquids	74

## Accessories

Pipework connection	77
Sensors for CRE, CRIE, CRNE	82
Gauges for CRE, CRIE, CRNE	82

## Variants

Lists of variants - on request	83
Motors	83
Connections and other variants	83
Shaft seals	83
Pumps	83

## Quotation text

WebCAPS	89
WinCAPS	90

# Mission

It is our mission — the basis of our existence — to successfully develop, produce and sell high-quality pumps and pumping systems worldwide, contributing to a better quality of life and a healthy environment



Bjerringbro, Denmark



Fresno, California



Olathe, Kansas



Monterrey, Mexico



Allentown, Pennsylvania



Oakville, Ontario

- The world's leading pump company
- World's largest manufacturer of circulator pumps
- World headquarters in Denmark
- North American headquarters in Kansas City - Manufacturing in Fresno, California
- 80 companies in 45 countries
- More than 16 million motors and pumps produced annually worldwide
- North American companies operating in USA, Canada and Mexico
- Continuous reinvestment in growth and development enables the company to **BE** responsible, **THINK** ahead, and **INNOVATE**

## Introduction

This data booklet deals with CR, CRI and CRN as well as CRE, CRIE and CRNE pumps.

### CR, CRI, CRN



TM02 7698 3803

**Fig. 1** CR, CRI and CRN pumps

CR, CRI, CRN pumps are vertical multistage centrifugal pumps. The in-line design enables the pump to be installed in a horizontal one-pipe system where the suction and discharge ports are in the same horizontal plane and have the same pipe dimensions. This design provides a more compact pump design and pipework.

Grundfos CR pumps come with various pump sizes and various numbers of stages to provide the flow and the pressure required.

CR pumps are suitable for a variety of applications from pumping of potable water to pumping of chemicals. The pumps are therefore used in a wide variety of pumping systems where the performance and material of the pump meet specific demands.

The CR pumps consist of two main components: the motor and the pump unit. The motor on a CR pump is a heavy-duty Grundfos specified motor.

The pump unit consists of optimized hydraulics, various types of connections, an outer sleeve, a top and various other parts.

CR pumps are available in various material versions according to the pumped liquid.

### CRE, CRIE, CRNE



TM02 7397 3403

**Fig. 2** CRE, CRIE and CRNE pumps

CRE, CRIE, CRNE pumps are built on the basis of CR, CRI, CRN pumps.

CRE, CRIE, CRNE pumps belong to the so-called E-pump family and are referred to as E-pumps.

The difference between the CR and the CRE pump range is the motor. CRE, CRIE, CRNE pumps are fitted with an E-motor, i.e. a motor with built-in frequency control.

The motor of the CRE pump is a Grundfos MLE motor. Frequency control enables continuously variable control of motor speed, which makes it possible to set the pump to operation at any duty point. The aim of continuously variable control of the motor speed is to adjust the performance to a given requirement.

CRE, CRIE and CRNE pumps are available with an integrated pressure sensor connected to the frequency control.

The pump materials are the same as those of the CR, CRI, CRN pump range.

### Selecting a CRE pump

Select a CRE pump if:

- controlled operation is required, i.e. consumption fluctuates;
- constant pressure is required,
- communication with the pump is required.

Adaptation of performance through frequency-controlled speed control offers obvious advantages:

- Energy savings.
- Increased comfort.
- Control and monitoring of the pump performance.



## Performance range - CR, CRI, CRN

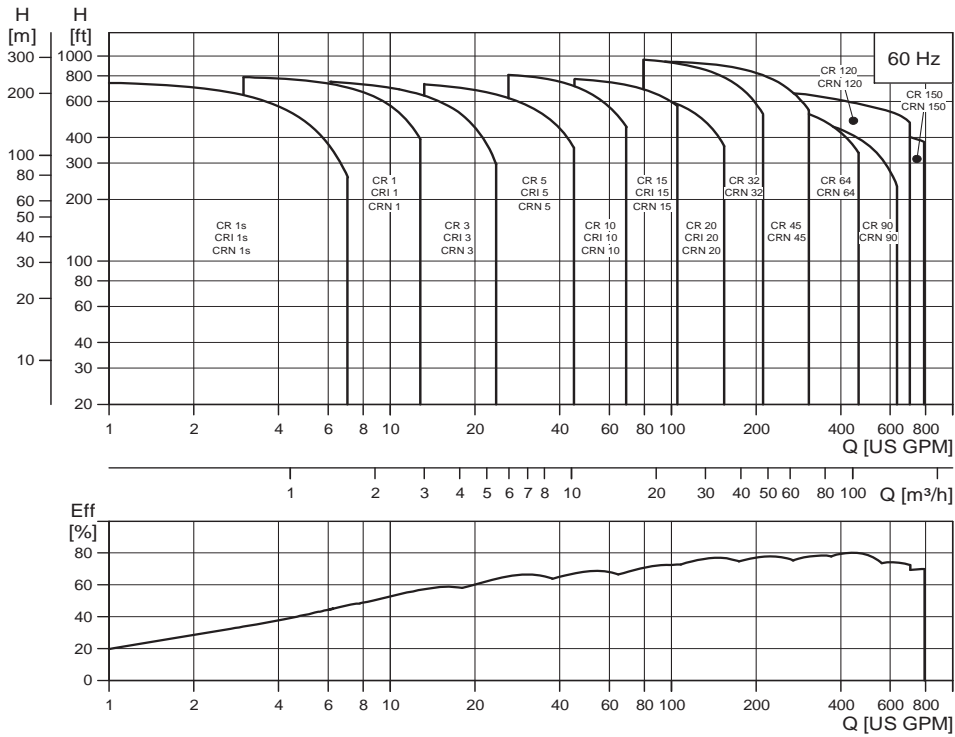

TM02 5518 0209

## Performance range - CRE, CRIE, CRNE

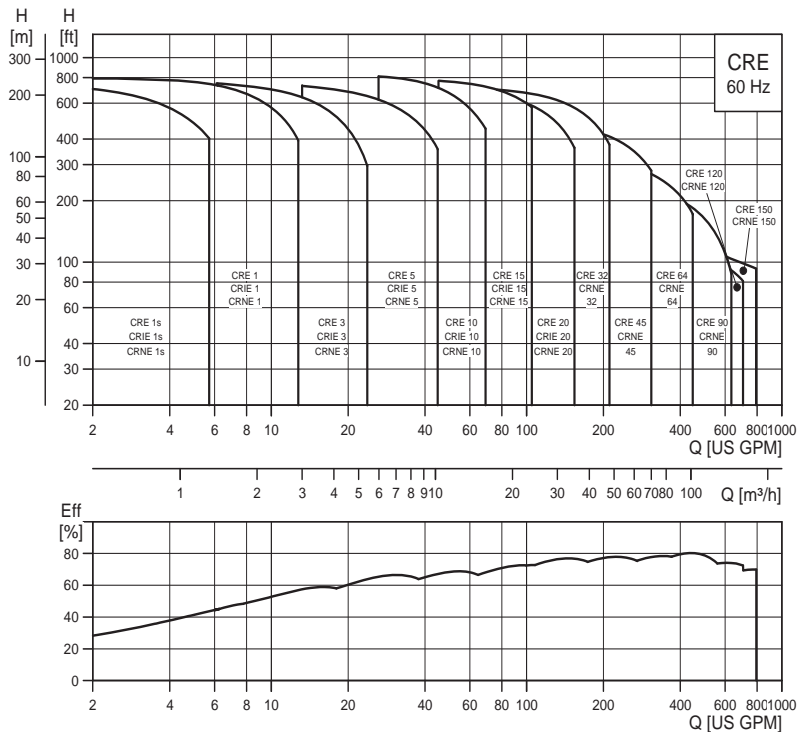

TM05 1598 3411

## Product range

Range	CR 1s	CR 1	CR 3	CR 5	CR 10	CR 15	CR 20
Nominal flow rate [US GPM]	4.5	8.5	15	30	55	95	110
Temperature range [°F]	-4 to +250						
Temperature range [°F] - on request	-40 to +356						
Max. working pressure [psi]	362	362	362	362	362	362	362
Max. working pressure [psi] - on request	-	725	725	725	725	725	725
Max. pump efficiency [%]	35	49	59	67	70	72	72
<b>CR pumps</b>							
CR: Flow range [US GPM]	0.5-5.7	1 - 12.8	1.5 - 23.8	3 - 45	5.5 - 70	9.5 - 125	11-155
CR: Max. pump pressure (H[ft])	760	790	790	780	820	800	700
CR: Motor power [Hp]	.33 - 2	.33 - 3	.33 - 5	.75 - 7.5	.75 - 15	2 - 25	3-25
<b>CRE pumps</b>							
CRE: Flow range [US GPM]	-	0 - 12.8	0 - 23.8	0 - 45	0 - 70	0 - 125	0-155
CRE: Max. pump pressure (H[ft])	-	790	790	780	820	800	700
CRE: Motor power [Hp]	-	.33 - 3	.33 - 5	.75 - 7.5	.75 - 15	2 - 25	3-25
<b>Version</b>							
CR, CRE: Cast iron and stainless steel AISI 304	●	●	●	●	●	●	●
CRI, CRIE: Stainless steel AISI 304	●	●	●	●	●	●	●
CRN, CRNE: Stainless steel AISI 316	●	●	●	●	●	●	●
CRT, CRTE: Titanium	-	See CRT, CRTE product guide					-
<b>CR, CRE pipe connection</b>							
Oval flange (NPT)	1"	1"	1"	1.25"	2"	2"	2"
Oval flange (NPT) - on request	1.25"	1.25"	1.25"	1"	1.5"	-	-
ANSI flange size	1.25"	1.25"	1.25"	1.25"	2"	2"	2"
ANSI flange size - on request	-	-	-	-	-	-	-
ANSI flange class	250 lb.	250 lb.	250 lb.	250 lb.	250 lb.	250 lb.	250 lb.
<b>CRI, CRIE pipe connection</b>							
Oval flange (NPT)	1"	1"	1"	1.25"	2"	2"	2"
Oval flange (NPT) - on request	1.25"	1.25"	1.25"	1"	1.5"	-	-
ANSI flange size	1.25"	1.25"	1.25"	1.25"	2"	2"	2"
ANSI flange class	300 lb.	300 lb.	300 lb.	300 lb.	300 lb.	300 lb.	300 lb.
Clamp coupling (NPT) - on request	1", 1.25"	1", 1.25"	1", 1.25"	1", 1.25"	1.5", 2"	1.5", 2"	1.5", 2"
Union (NPT ext. Thread) - on request	2"	2"	2"	2"	-	-	-
<b>CRN, CRNE pipe connection</b>							
PJE (Victaulic)	1.25"	1.25"	1.25"	1.25"	2"	2"	2"
PJE (Victaulic) - on request	-	-	-	-	-	-	-
ANSI flange size	1.25"	1.25"	1.25"	1.25"	2"	2"	2"
ANSI flange size - on request	-	-	-	-	-	-	-
ANSI flange class	300 lb.	300 lb.	300 lb.	300 lb.	300 lb.	300 lb.	300 lb.
Clamp coupling (NPT) - on request	1", 1.25"	1", 1.25"	1", 1.25"	1", 1.25"	1.5", 2"	1.5", 2"	1.5", 2"
Union (NPT ext. Thread) - on request	2"	2"	2"	2"	-	-	-
<b>CRT pipe connection</b>							
PJE coupling (Vitalic)	-	1.25"	1.25"	1.25"	2"	2"	-
ANSI flange size - on request	-	-	-	-	2"	2"	-

● Available

# Product overview

CR, CRI, CRN, CRE, CRIE, CRNE

Range	CR 32	CR 45	CR 64	CR 90	CR 120	CR 150
Nominal flow rate [US GPM]	140	220	340	440	610	750
Temperature range [°F]	-22 to +250 <sup>1)</sup>			-22 to +250 <sup>1) &amp; 2)</sup>		
Temperature range [°F] - on request	-40 to +356			-		
Max. working pressure [psi]	435	435	360	360	360	360
Max. working pressure [psi] - on request	580	580	580	580	-	-
Max. pump efficiency [%]	76	78	79	80	75	73
<b>CR pumps</b>						
CR: Flow range [US GPM]	14-210	22-310	34-450	44-630	61-700	75-790
CR: Max. pump pressure (H[ft])	995	940	565	595	685	570
CR: Motor power [Hp]	5-50	7.5-60	10-60	15-60	20-100	25-100
<b>CRE pumps</b>						
CRE: Flow range [US GPM]	0-210	0-310	0-450	0-630	0-700	0-790
CRE: Max. pump pressure (H[ft])	720	490	335	285	140	155
CRE: Motor power [Hp]	5-30	7.5-30	10-30	15-30	20-25	25-30
<b>Version</b>						
CR, CRE: Cast iron and stainless steel AISI 304	●	●	●	●	●	●
CRI, CRIE: Stainless steel AISI 304	-	-	-	-	-	-
CRN, CRNE: Stainless steel AISI 316	●	●	●	●	●	●
CRT, CRTE: Titanium	-	-	-	-	-	-
<b>CR, CRE pipe connection</b>						
Oval flange (NPT)	-	-	-	-	-	-
Oval flange (NPT) - on request	-	-	-	-	-	-
ANSI flange size	2.5"	3"	4"	4"	5" <sup>3)</sup>	5" <sup>3)</sup>
ANSI flange size - on request	3"	4"	5" <sup>3)</sup>	5" <sup>3)</sup>	6"	6"
ANSI flange class	125/ 250 lb.	125/ 250 lb.	125/ 250 lb.	125/ 250 lb.	125/ 250 lb.	125/ 250 lb.
<b>CRI, CRIE pipe connection</b>						
Oval flange (NPT)	-	-	-	-	-	-
Oval flange (NPT) - on request	-	-	-	-	-	-
ANSI flange size	-	-	-	-	-	-
ANSI flange class	-	-	-	-	-	-
Clamp coupling (NPT) - on request	-	-	-	-	-	-
Union (NPT ext. Thread) - on request	-	-	-	-	-	-
<b>CRN, CRNE pipe connection</b>						
PJE (Victaulic)	-	-	-	-	-	-
PJE (Victaulic) - on request	3"	4"	4"	4"	4"	4"
ANSI flange size	2.5"	3"	4"	4"	5"	5"
ANSI flange size - on request	3"	-	-	5"	6"	6"
ANSI flange class	150/ 300 lb.	150/ 300 lb.	150/ 300 lb.	150/ 300 lb.	150/ 300 lb.	150/ 300 lb.
Clamp coupling (NPT) - on request	-	-	-	-	-	-
Union (NPT ext. Thread) - on request	-	-	-	-	-	-
<b>CRT pipe connection</b>						
PJE coupling (Vitaallic)	-	-	-	-	-	-
ANSI flange size - on request	-	-	-	-	-	-

● Available

<sup>1)</sup> CRN 32 to CRN 90 with HQQE shaft seal: -40 °F to +250 °F

<sup>2)</sup> CR, CRN 120 and 150 with 75 or 100 Hp motors with HBQE shaft seal: 0 °F to +250 °F

<sup>3)</sup> CR 5" flange is not manufactured to ANSI specification. Gasket contact surface is approximately 0.25". CR 6" ANSI flange adapter is manufactured to ANSI B16.5 specification.

## Applications

Application	CR, CRI	CRN	CRE, CRNE
<b>Water supply</b>			
Filtration and transfer at waterworks	●	○	●
Distribution from waterworks	●	○	●
Pressure boosting in mains	●	○	●
Pressure boosting in high-rise buildings, hotels, etc.	●	○	●
Pressure boosting for industrial water supply	●	○	●
<b>Industry</b>			
<b>Pressure boosting in...</b>			
process water systems	●	●	●
washing and cleaning systems	●	●	●
vehicle washing tunnels	●	○	●
fire fighting systems	●		
<b>Liquid transfer in...</b>			
cooling and air-conditioning systems (refrigerants)	●	○	●
boiler feed and condensate systems	●	○	●
machine tools (cooling lubricants)	●	●	●
aquafarming ★	●	○	
<b>Transfer of...</b>			
oils and alcohols	●	●	●
acids and alkalis ★		●	●
glycol and coolants	●		●
<b>Water treatment</b>			
Ultra-filtration systems		●	●
Reverse osmosis systems ★		●	●
Softening, ion exchange, demineralizing systems		●	●
Distillation systems		●	●
Separators	●	●	●
Swimming pools ★		●	●
<b>Irrigation</b>			
Field irrigation (flooding)	●	○	
Sprinkler irrigation	●	○	●
Drip-feed irrigation	●	○	

● Recommended version.

○ Alternative version.

★ CRT, CRTE version available. For further information about CRT, CRTE pumps see, "Pumped liquids" page 74 or related CRT, CRTE product guide.

## Pump

The CR and CRE pump is a non-self-priming, vertical multistage centrifugal pump. The pumps are available with a Grundfos standard motor (CR pumps) or a frequency-controlled motor (CRE pumps).

The pump consists of a base and a pump head. The chamber stack and the outer sleeve are secured between the pump head and the base by means of staybolts. The base has suction and discharge ports on the same level (in-line).

All pumps are equipped with a maintenance-free mechanical shaft seal of the cartridge type.

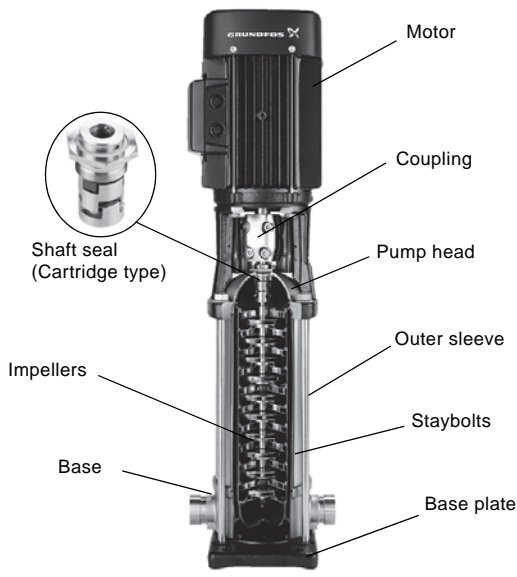

Fig. 3 CR pump

CR pump with ANSI/NSF 61 listing is available. See UL file MH26400 or contact Grundfos.

## Motor

### Grundfos standard motors - ML and Baldor® motors

CR, CRI and CRN pumps are fitted with a Grundfos specified motor. The motors are all heavy-duty 2-pole, NEMA C-face motors.

### Frequency-controlled motors - MLE motors

CRE, CRIE and CRNE pumps are fitted with a totally enclosed, fan-cooled, 2-pole motor with integrated variable frequency drive.

From 0.5 Hp to 1.5 Hp Grundfos offers CRE pumps fitted with single-phase MLE motors (1 x 208-230 V). From 1.0 Hp to 30 Hp Grundfos offers CRE pumps fitted with three-phase MLE motors (3 x 460-480 V). From 1.5 Hp to 7.5 Hp Grundfos offers CRE pumps fitted with three-phase MLE motors (3 x 208-230 V).

## Electrical data

<b>Mounting designation</b>	NEMA
<b>Insulation class</b>	F & B
<b>Efficiency class*</b>	Energy efficient Premium efficiency - on request for 15 Hp and above
<b>Enclosure class</b>	TEFC - Totally Enclosed Fan Cooled (Grundfos standard) ODP - Open Drip Proof - on request
<b>60 Hz Standard voltages</b>	1 x 115/208-230 V 3 x 208-230/460 V 3 x 575 V

The motors are rated for:

	Baldor	ML/MLE	MLE
<b>Approvals</b>			

\* 1 - 10 Hp ML motors are premium efficiency as standard

## Optional motors

The Grundfos standard range of motors covers a wide variety of application demands. However, for special applications or operating conditions, custom-built motor solutions can be provided.

For special applications or operating conditions, Grundfos offers custom-built motors such as:

- explosion proof motors,
- motors with anti-condensation heating unit,
- low-noise motors,
- premium efficiency motors,
- motors with thermal protection.

## Motor protection

Single-phase Grundfos specified motors up to 7.5 hp have a built-in thermal overload switch.

Three-phase motors **must** be connected to a motor starter in accordance with local regulations.

## Terminal box positions

As standard the terminal box is mounted on the suction side of the pump.

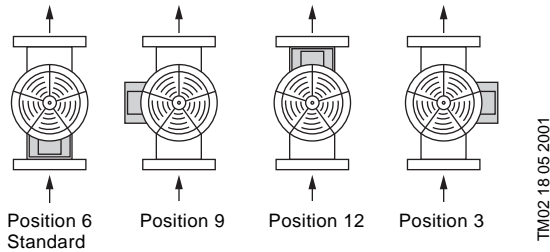

Fig. 4 Terminal box positions

## Ambient temperature

Ambient temperature: Maximum +104 °F.

If the ambient temperature exceeds +104 °F or if the motor is located 3280 feet above sea level or higher, the motor output (P2) must be reduced due to the low cooling effect of the air. In such cases, it may be necessary to use a motor with a higher output.

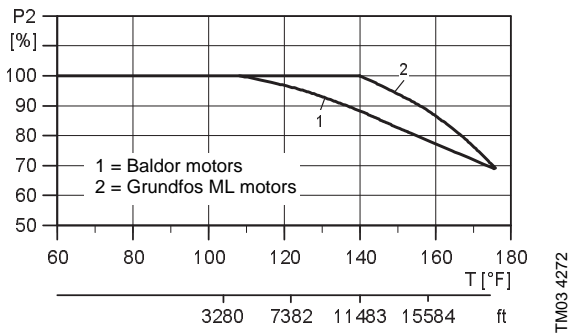

Fig. 5 Relationship between motor output (P2) and ambient temperature

## Viscosity

The pumping of liquids with densities or kinematic viscosities higher than those of water will cause a considerable pressure drop, a drop in the hydraulic performance and a rise in the power consumption.

In such situations the pump should be equipped with a larger motor. If in doubt, contact Grundfos.

## Examples of E-pump applications

CRE, CRIE and CRNE pumps are the ideal solution in a number of applications characterized by a need for variable flow at constant pressure. The pumps are suited for water supply systems and pressure boosting, but also industrial applications.

Depending on the nature of the application, the pumps offer energy-savings, increased comfort or improved processing.

### E-pumps in the service of industry

Industry uses a large number of pumps in many different applications. Demands on pumps in terms of pump performance and mode of operation make speed control a must in many applications.

Below are mentioned some of the applications in which E-pumps are often used.

#### Constant pressure

- Water supply,
- Washing and cleaning systems,
- Distribution from waterworks,
- Humidifying systems,
- Water treatment systems,
- Process boosting systems, etc.

**Example:** Within industrial water supply, E-pumps with integrated pressure sensors are used to ensure a constant pressure in the piping network. From the sensor, the E-pump receives inputs about changes of pressure as a result of changes in the consumption. The E-pump responds to the input by adjusting the flow until the pressure is equalized. The constant pressure is stabilized once more on the basis of a preset setpoint.

#### Constant temperature

- Air-conditioning systems at industrial plants,
- Industrial cooling systems,
- Industrial freezing systems,
- Casting and molding tools, etc.

**Example:** In industrial freezing systems, E-pumps with temperature sensor increase comfort and lower operating costs compared with pumps without a temperature sensor.

An E-pump continuously adapts its performance to the changing demands reflected in the differences in temperature of the liquid circulating in the freezing system. Thus, the lower the demand for cooling, the smaller the quantity of liquid circulated in the system and vice versa.

#### Constant flow

- Steam boiler systems,
- Condensate systems,
- Sprinkler irrigation systems,
- Chemical industry, etc.

**Example:** In a steam boiler, it is important to be able to monitor and control pump operation to maintain a constant level of water in the boiler.

By using an E-pump with level sensor mounted in the boiler, it is possible to maintain a constant water level. A constant water level ensures optimum and cost-efficient operation as a result of a stable steam production.

#### Dosing

- Chemical industry (i.e. control of pH-values),
- Petrochemical industry,
- Paint industry
- Degreasing systems,
- Bleaching systems, etc.

**Example:** In the petrochemical industry, E-pumps with pressure sensors are used as dosing pumps. The E-pumps help to ensure that the correct mixture ratio is achieved when more liquids are combined.

E-pumps functioning as dosing pumps improve processing and offer energy-savings.

#### E-pumps in commercial building services

Commercial building services use E-pumps to maintain a constant pressure or a constant temperature based on a variable flow.

E-pumps are used in applications such as

#### Constant pressure

- Water supply in high-rise buildings i.e. office buildings, hotels, etc.

**Example:** E-pumps with pressure sensors are used for water supply in high-rise buildings to ensure a constant pressure even at the highest draw-off point. As the consumption pattern and by that the pressure changes during the day, the E-pump continuously adapts its performance until the pressure is equalized.

#### Constant temperature

- Air-conditioning systems in hotels, schools,
- Building cooling systems, etc.

**Example:** E-pumps are an excellent solution in buildings where constant temperature is essential. E-pumps keep the temperature constant in air-conditioned high-rise glass buildings, irrespective of the seasonal fluctuations of the out-door temperature, and various heat impacts inside the building.

## Control options of E-pumps

Communication with CRE, CRIE, CRNE pumps is possible by means of

- a central management system,
- remote control (Grundfos R100) or
- a control panel.

The purpose of controlling an E-pump is to monitor and control the pressure, temperature, flow and liquid level of the system.

### Central management system

Communication with the E-pump is possible even though the operator is not present near the E-pump. Communication is enabled by having connected the E-pump to a central management system allowing the operator to monitor and change control modes and setpoint settings of the E-pump.

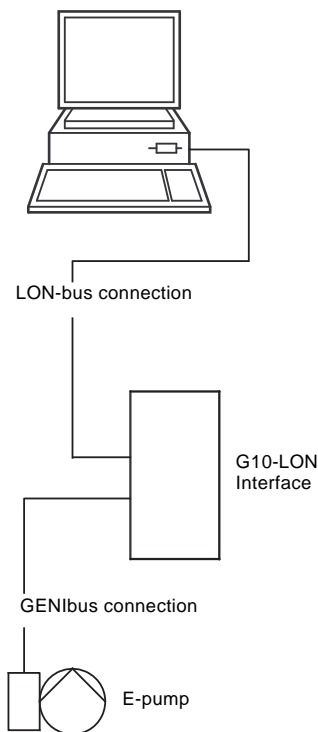

Fig. 6 Structure of a central management system

TM06592 1103

### Remote control

The R100 remote control produced by Grundfos is available as an accessory.

The operator communicates with the E-pump by pointing the IR-signal transmitter at the control panel of the E-pump terminal box.

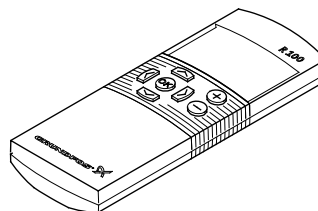

TM00 4498 2802

Fig. 7 R100 remote control

On the R100 display it is possible to monitor and change control modes and settings of the E-pump.

### Control panel

The control panel of the E-pump terminal box makes it possible to change the setpoint settings manually.

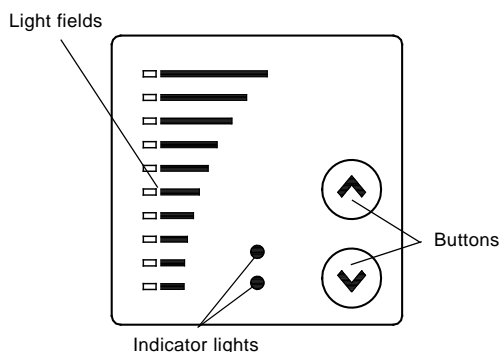

TM00 7600 1196

Fig. 8 Control panel on CRE pump

## Control modes for E-pumps

Grundfos offers CRE, CRIE and CRNE pumps in two different variants:

- CRE, CRIE and CRNE with integrated pressure sensor
- CRE, CRIE and CRNE without sensor.

### CRE, CRIE, CRNE with integrated pressure sensor

CRE, CRIE and CRNE pumps with integrated pressure sensors are suitable for applications where you want to control the pressure after the pump, irrespective of the flow. For further information, see the section *Examples of E-pump applications* on page 11. Signals of pressure changes in the piping system are transmitted continuously from the sensor to the pump.



The pump responds to the signals by adjusting its performance up or down to compensate for the pressure difference between the actual and the desired pressure. As this adjustment is a continuous process, a constant pressure is maintained in the piping system.



TM02 7398 3403

**Fig. 9** CRE, CRIE and CRNE pumps

A CRE, CRIE or CRNE pump with integrated pressure sensor facilitates installation and commissioning. CRE, CRIE and CRNE pumps with integrated pressure sensor can be set to:

- constant-pressure mode (factory setting) or
- constant-curve mode.

In **constant-pressure** mode, the pump maintains a preset pressure after the pump, irrespective of the flow, see figure below.

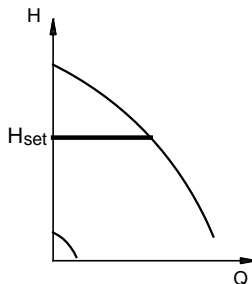

TM00 9322 4796

**Fig. 10** Constant pressure mode

In **constant-curve** mode, the pump is not controlled. It can be set to pump according to a preset pump characteristic within the range from min. curve to max. curve, see figure below.

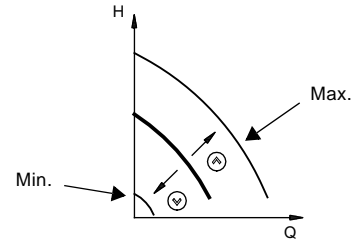

TM00 9323 4796

**Fig. 11** Constant curve mode

### CRE, CRIE and CRNE without sensor

CRE, CRIE and CRNE pumps without sensors are suitable for applications where

- uncontrolled operation is required
- you want to fit another sensor later in order to control the flow, temperature, differential temperature, liquid level, pH value, etc at some arbitrary point in the system.

CRE, CRIE and CRNE pumps without sensor can be set to:

- controlled-operation mode or
- uncontrolled-operation mode (factory-setting).

In **controlled**-operation mode, the pump adjusts its performance to the desired setpoint, see figure below.

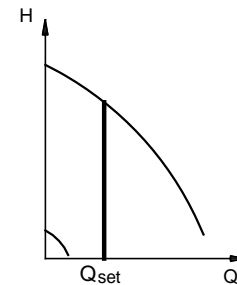

TM02 7264 2803

**Fig. 12** Constant flow mode

In **uncontrolled**-operation mode, the pump operates according to the constant curve set, see figure below.

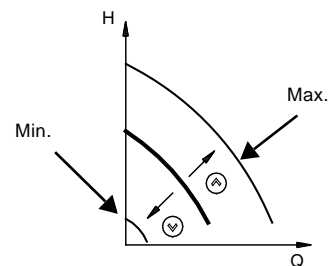

TM00 9323 4796

**Fig. 13** Constant curve mode

CRE, CRIE and CRNE pumps can be fitted with sensor types listed on page 82.

## CR(E) 1s, 1, 3, 5, 10, 15 and 20



TM02 1198 0601 - GR7377 - GR7379

### Sectional drawing

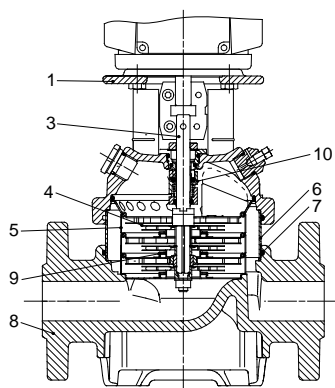

TM02 1194 1403

### Materials: CR(E)

Pos.	Designation	Materials	AISI/ASTM
1	Pump head	Cast iron	A 48-30 B
3	Shaft	Stainless steel	AISI 316 <sup>1)</sup> AISI 431 <sup>2)</sup>
4	Impeller	Stainless steel	AISI 304
5	Chamber	Stainless steel	AISI 304
6	Outer sleeve	Stainless steel	AISI 304
7	O-ring for outer sleeve	EPDM or FKM	
8	Base	Cast iron	A 48-30 B
9	Neck ring	PTFE	
10	Shaft seal	Cartridge type	
	Bearing rings	Silicon carbide	
	Rubber parts	EPDM or FKM	
12	FJG flange	Cast iron	A 48-30 B

<sup>1)</sup> CR(E) 1s, 1, 3, 5

<sup>2)</sup> CR(E) 10, 15, 20

<sup>3)</sup> Stainless steel available on request.

<sup>4)</sup> CF 8M is cast equivalent of AISI 316 stainless steel.

<sup>5)</sup> CRI(E)/CRN(E) 1s, 1, 3, 5

<sup>6)</sup> CRN(E) 10, 15, 20

<sup>7)</sup> CRI(E) 10, 15, 20

## CRI(E), CRN(E) 1s, 1, 3, 5, 10, 15 and 20



TM02 1808 2001 - GR7373 - GR7375

### Sectional drawing

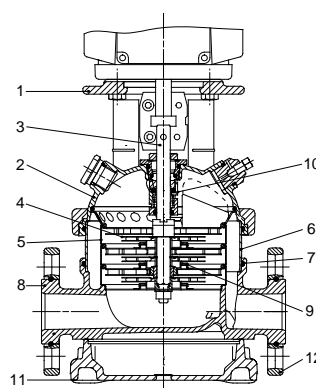

TM03 2156 3805

### Materials: CRI(E), CRN(E)

Pos.	Designation	Materials	AISI/ASTM
1	Pump head	Cast iron <sup>3)</sup>	A 48-30 B
2	Pump head cover	Stainless steel	CF 8M <sup>4)</sup>
3	Shaft	Stainless steel	AISI 316 <sup>5)</sup> AISI 329 <sup>6)</sup> AISI 431 <sup>7)</sup>
8	Base	Stainless steel	CF 8M <sup>4)</sup>
9	Neck ring	PTFE	
10	Shaft seal	Cartridge type	
11	Base plate	Cast iron <sup>3)</sup>	A 48-30 B
	Bearing rings	Silicon carbide	
	Rubber parts	EPDM or FKM	
<b>CRI(E)</b>			
4	Impeller	Stainless steel	AISI 304
5	Chamber	Stainless steel	AISI 304
6	Outer sleeve	Stainless steel	AISI 304
7	O-ring for outer sleeve	EPDM or FKM	
12	FGJ flange ring	Ductile iron <sup>3)</sup>	A 65-45-12
	Oval flange	Stainless steel	AISI 316
<b>CRN(E)</b>			
4	Impeller	Stainless steel	AISI 316
5	Chamber	Stainless steel	AISI 316
6	Outer sleeve	Stainless steel	AISI 316
7	O-ring for outer sleeve	EPDM or FKM	
12	FGJ flange ring	Ductile iron <sup>3)</sup>	A 65-45-12

## CR(E) 32, 45, 64 and 90



TM01 2150 1298

### Sectional drawing

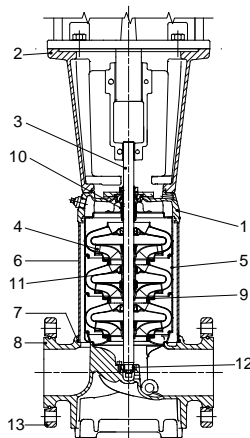

TM03 2157 3805

### Materials: CR(E)

Pos.	Designation	Materials	AISI/ASTM
1	Pump head	Ductile iron	A 65-45-12
2	Motor stool	Cast iron	A 48-30 B
3	Shaft	Stainless steel	AISI 431
4	Impeller	Stainless steel	AISI 304
5	Chamber	Stainless steel	AISI 304
6	Outer sleeve	Stainless steel	AISI 304
7	O-ring for outer sleeve	EPDM or FKM	
8	Base	Ductile iron	A 65-45-12
9	Neck ring	Acoflon 215	
10	Shaft seal	Cartridge type	
11	Bearing ring	Bronze	
12	Bottom bearing ring	Tungsten carbide/ Tungsten carbide	
13	Flange ring	Ductile iron <sup>2)</sup>	A 65-45-12
	Rubber parts	EPDM or FKM	

## CRN(E) 32, 45, 64 and 90



TM02 7399 3403

### Sectional drawing

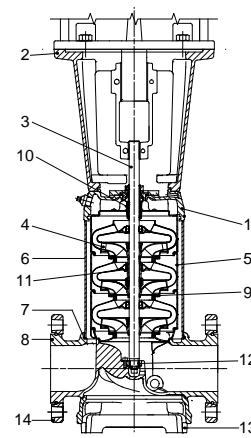

TM03 2158 3805

### Materials: CRN(E)

Pos.	Designation	Materials	AISI/ASTM
1	Pump head	Stainless steel	CF 8M <sup>1)</sup>
2	Motor stool	Cast iron	A 48-30 B
3	Shaft	Stainless steel	SAF 2205
4	Impeller	Stainless steel	AISI 316
5	Chamber	Stainless steel	AISI 316
6	Outer sleeve	Stainless steel	AISI 316
7	O-ring for outer sleeve	EPDM or FKM	
8	Base	Stainless steel	CF 8M <sup>1)</sup>
9	Neck ring	Acoflon 215	
10	Shaft seal	Cartridge type	
11	Bearing ring	Carbon-graphite filled PTFE	
12	Bottom bearing ring	Tungsten carbide/ Tungsten carbide	
13	Base plate	Ductile iron <sup>2)</sup>	A 65-45-12
14	Flange ring	Ductile iron <sup>2)</sup>	A 65-45-12
	Rubber parts	EPDM or FKM	

<sup>1)</sup> CF 8M is cast equivalent of AISI 316 stainless steel.

<sup>2)</sup> Stainless steel available on request.

## CR(E) 120 and 150



GrA3731

Sectional drawing

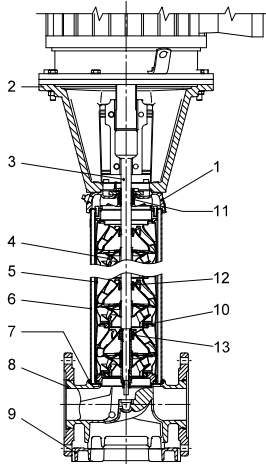

TM03 8835 2607

### Materials: CR(E)

Pos.	Designation	Materials	AISI/ASTM
1	Pump head	Ductile iron	A 536 65-45-12
2	Motor stool (15-60 Hp)	Cast iron	A48-30 B
	Motor stool (75-100 Hp)	Ductile iron	A 536 65-45-12
3	Shaft	Stainless steel	AISI 431
4	Impeller	Stainless steel	AISI 304
5	Chamber	Stainless steel	AISI 304
6	Outer sleeve	Stainless steel	AISI 316
7	O-ring for outer sleeve	EPDM or FKM	
8	Base	Ductile iron	A 536 65-45-12
9	Base plate	Ductile iron	A 536 65-45-12
10	Neck ring	PTFE	
11	Shaft seal <sup>1)</sup>	Cartridge type	
12	Support bearing	PTFE	
13	Bearing rings	Silicone carbide	
	Rubber parts	EPDM or FKM	

<sup>1)</sup> Ø22 mm shaft, 15-60 Hp. Ø32 mm shaft, 75-100 Hp.

## CRN(E) 120 and 150



GrA3732 - GrA3735

Sectional drawing

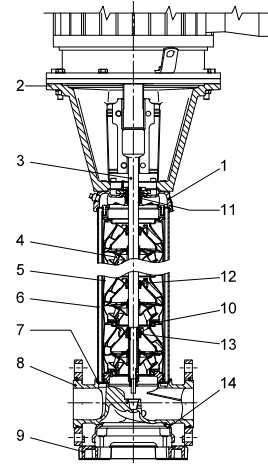

TM03 8836 2607

### Materials: CRN(E)

Pos.	Designation	Materials	AISI/ASTM
1	Pump head	Stainless steel	A 351 CF 8M
2	Motor stool (15-60 Hp)	Cast iron	A48-30 B
	Motor stool (75-100 Hp)	Ductile iron	A 536 65-45-12
3	Shaft	Stainless steel	SAF 2205
4	Impeller	Stainless steel	AISI 316
5	Chamber	Stainless steel	AISI 316
6	Outer sleeve	Stainless steel	AISI 316
7	O-ring for outer sleeve	EPDM or FKM	
8	Base	Stainless steel	A 351 CF 8M
9	Base plate	Ductile iron <sup>1)</sup>	A 536 65-45-12
10	Neck ring	PTFE	
11	Shaft seal <sup>2)</sup>	Cartridge type	
12	Support bearing	PTFE	
13	Bearing rings	Silicone carbide	
14	Base plate	Ductile iron <sup>1)</sup>	A 536 65-45-12
	Rubber parts	EPDM or FKM	

<sup>1)</sup> Stainless steel available on request.

<sup>2)</sup> Ø22 mm shaft, 15-60 Hp. Ø32 mm shaft, 75-100 Hp.

## Type keys

### CR(E), CRI(E), CRN(E)

Example	CR	E	32	(s)	-4	-2	-A	-G	-G	-E	-HQQE
Type range: CR, CRI, CRN											
Pump with integrated frequency control											
Nominal flow rate [m <sup>3</sup> /h]											
All impellers with reduced diameter (applies only to CR, CRI, CRN 1s)											
Number of impellers											
Number of reduced diameter impellers (CR(E), CRN(E) 32, 45, 64, 90, 120, and 150)											
Code for pump version											
Code for pipe connection											
Code for materials											
Code for rubber parts											
Code for shaft seal											

## Codes

Example	A	-G	-A	-E	-H	QQ	E
<b>Pump version</b>							
A Basic version <sup>1)</sup>							
B Oversize motor							
E Certificate/approval							
F CR pump for high temperatures (air-cooled top assembly)							
H Horizontal version							
HS High-pressure pump with high speed MLE motor							
I Different pressure rating							
J Pump with different max speed							
K Pump with low NPSH							
M Magnetic drive							
N Fitted with sensor							
P Undersize motor							
R Horizontal version with bearing bracket							
SF High pressure pump							
T Over size motor (two flange sizes bigger)							
U NEMA version <sup>1)</sup>							
X Special version							
<b>Pipe connection</b>							
A Oval flange							
B NPT thread							
CA FlexiClamp (CRI(E), CRN(E) 1, 3, 5, 10, 15, 20)							
CX Triclamp (CRI(E), CRN(E) 1, 3, 5, 10, 15, 20)							
F DIN flange							
G ANSI flange							
J JIS flange							
N Changed diameter of ports							
P PJE coupling							
X Special version							

Example	A	-G	-A	-E	-H	QQ	E
<b>Materials</b>							
A Basic version							
D Carbon-graphite filled PTFE (bearings)							
G Wetted parts AISI 316							
GI All parts stainless steel, wetted parts AISI 316							
I Wetted parts AISI 304							
II All parts stainless steel, wetted parts AISI 304							
K Bronze (bearings)							
S SiC bearings + PTFE neck rings							
X Special version							
<b>Code for rubber parts</b>							
E EPDM							
F FXM							
K FFKM							
V FKM							
<b>Shaft seal</b>							
A O-ring seal with fixed driver							
B Rubber bellows seal							
E Cartridge seal with O-ring							
H Balanced cartridge seal with O-ring							
K Metal bellows cartridge seal							
O Double seal, back-to-back							
P Double seal, tandem							
X Special version							
B Carbon, synthetic resin-impregnated							
H Cemented tungsten carbide, embedded (hybrid)							
Q Silicon carbide							
U Cemented tungsten carbide							
X Other ceramics							
E EPDM							
F FXM							
K FFKM							
V FKM							

<sup>1)</sup> In August 2003 the NEMA version pump code was discontinued for all material numbers created by Grundfos manufacturing companies in North America. The NEMA version pump code will still remain in effect for existing material numbers. NEMA version pumps built in North America after this change will have either an A or U as the pump version code depending on the date the material number was created.

# Operating and inlet pressure

CR, CRI, CRN, CRE, CRIE, CRNE

## Maximum operating pressure and temperature range

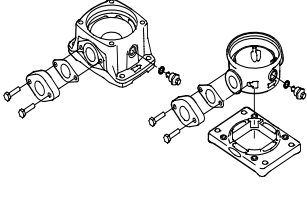
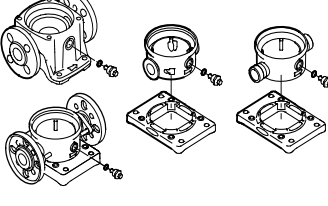
	Oval flange		ANSI, Clamp, PJE	
				
	Max. permissible operating pressure	Liquid temperature range	Max. permissible operating pressure	Liquid temperature range
CR, CRI, CRN 1s	232 [psi]	-4 °F to +248 °F	362 [psi]	-4 °F to +248 °F
CR(E), CRI(E), CRN(E) 1	232 [psi]	-4 °F to +248 °F	362 [psi]	-4 °F to +248 °F
CR(E), CRI(E), CRN(E) 3	232 [psi]	-4 °F to +248 °F	362 [psi]	-4 °F to +248 °F
CR(E), CRI(E), CRN(E) 5	232 [psi]	-4 °F to +248 °F	362 [psi]	-4 °F to +248 °F
CR(E) 10-1	145 [psi]	-4 °F to +248 °F	-	-
CRI(E), CRN(E) 10-1	232 [psi]	-4 °F to +248 °F	-	-
CR(E), CRI(E) 10-1	-	-	232 [psi]	-4 °F to +248 °F
CR(E), CRI(E) 10-12	-	-	362 [psi]	-4 °F to +248 °F
CRN(E) 10	-	-	362 [psi]	-4 °F to +248 °F
CR(E) 15-1	145 [psi]	-4 °F to +248 °F	-	-
CRI(E), CRN(E) 15-1	232 [psi]	-4 °F to +248 °F	-	-
CR(E), CRI(E) 15-1	-	-	232 [psi]	-4 °F to +248 °F
CR(E), CRI(E) 15-9	-	-	362 [psi]	-4 °F to +248 °F
CRN(E) 15	-	-	362 [psi]	-4 °F to +248 °F
CR(E) 20-1	145 [psi]	-4 °F to +248 °F	-	-
CRI(E), CRN(E) 20-1	232 [psi]	-4 °F to +248 °F	-	-
CR(E), CRI(E) 20-1	-	-	232 [psi]	-4 °F to +248 °F
CR(E), CRI(E) 20-8	-	-	362 [psi]	-4 °F to +248 °F
CRN(E) 20	-	-	362 [psi]	-4 °F to +248 °F
CR(E), CRN(E) 32-1-1	-	-	232 [psi]	-22 °F to +248 °F
CR, CRN 32-6-2	-	-	435 [psi]	-22 °F to +248 °F
CR(E), CRN(E) 45-1-1	-	-	232 [psi]	-22 °F to +248 °F
CR(E), CRN(E) 45-4-1	-	-	435 [psi]	-22 °F to +248 °F
CR(E), CRN(E) 64-1-1	-	-	232 [psi]	-22 °F to +248 °F
CR(E), CRN(E) 64-4-2	-	-	435 [psi]	-22 °F to +248 °F
CR(E), CRN(E) 90-1-1	-	-	232 [psi]	-22 °F to +248 °F
CR(E), CRN(E) 90-4-2	-	-	435 [psi]	-22 °F to +248 °F
CR(E), CRN(E) 120-1-1	-	-	435 [psi]	-22 °F to +248 °F
CR(E), CRN(E) 150-1-1	-	-	435 [psi]	-22 °F to +248 °F

## Operating range of the shaft seal

The operating range of the shaft seal depends on operating pressure, pump type, type of shaft seal and liquid temperature. The following curves apply to clean water and water with anti-freeze liquids. For selecting the right shaft seal, see *List of pumped liquids* on page 74.

### CR 1s - CR 20

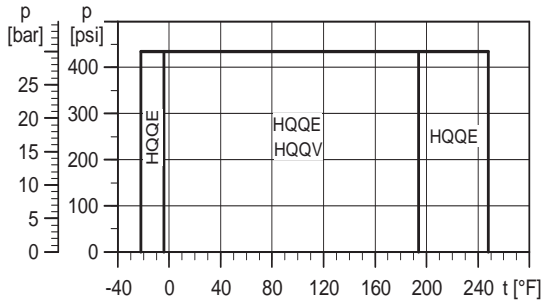

TM02 7537 3703

**Fig. 14** Operating range of standard shaft seals for CR 1s - CR 20

### CR 32 - CR 150 (3.0-60 Hp)

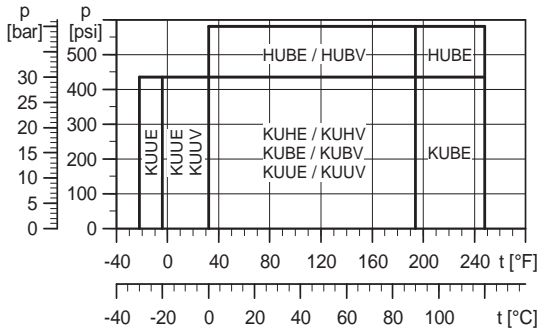

TM02 7873 0604

**Fig. 15** Operating range of standard shaft seals for CR 32 - CR 150 (3.0-60 Hp)

### CR 120 - CR 150 (75-100 Hp)

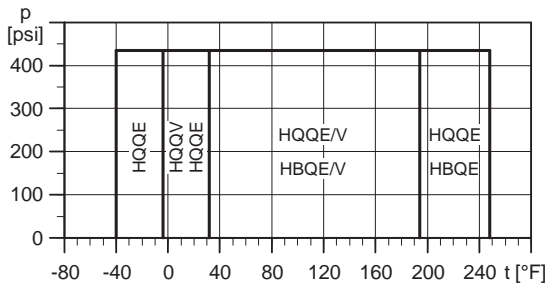

TM04 4415

**Fig. 16** Operating range of standard shaft seals for CR 120 - CR 150 (75-100 Hp)

Shaft seal	Description	Max. temp. range [ °F]
HQQE	O-ring (cartridge) (balanced seal), SiC/SiC, EPDM	-22 °F to +248 °F
HBQE	O-ring (cartridge) (balanced seal), Carbon/SiC, EPDM	+32 °F to +248 °F
HQQV	O-ring (cartridge) (balanced seal), SiC/SiC, FKM	-4 °F to +194 °F
HUBE	O-ring (cartridge) (balanced seal), TC/carbon, EPDM	+32 °F to +248 °F
HUBV	O-ring (cartridge) (balanced seal), TC/carbon, FKM	+32 °F to +194 °F
KUBE	Bellows, metal (cartridge), TC/carbon, EPDM	+32 °F to +248 °F
KUBV	Bellows, metal (cartridge), TC/carbon, FKM	+32 °F to +194 °F
KUHE	Bellows, metal (cartridge), TC/Carbon with embedded TC, EPDM	+32 °F to +194 °F
KUHV	Bellows, metal (cartridge), TC/Carbon with embedded TC, FKM	+32 °F to +194 °F
KUUE	Bellows, metal (cartridge), TC/TC, EPDM	-22 °F to +194 °F
KUUV	Bellows, metal (cartridge), TC/TC, FKM	-4 °F to +194 °F

**Note:** TC= tungsten carbide

See section *Lists of variants - on request* on page 83, in case of extreme temperatures:

- low temperatures down to -40 °F or
- high temperatures up to +356 °F.

## Maximum inlet pressure

The following table shows the maximum permissible inlet pressure. However, the current inlet pressure + the pressure against a closed valve **must** always be lower than the maximum permissible operating pressure.

If the maximum permissible operating pressure is exceeded, the conical bearing in the motor may be damaged and the life of the shaft seal reduced.

<b>CR, CRI, CRN 1s</b>		
1s-2	› 1s-27	145 [psi]
<b>CR(E), CRI(E), CRN(E) 1</b>		
1-2	› 1-25	145 [psi]
1-27		218 [psi]
<b>CR(E), CRI(E), CRN(E) 3</b>		
3-2	› 3-15	145 [psi]
3-17	› 3-25	218 [psi]
<b>CR(E), CRI(E), CRN(E) 5</b>		
5-2	› 5-9	145 [psi]
5-10	› 5-24	218 [psi]
<b>CR(E), CRI(E), CRN(E) 10</b>		
10-1	› 10-5	116 [psi]
10-6	› 10-17	145 [psi]
<b>CR(E), CRI(E), CRN(E) 15</b>		
15-1	› 15-2	116 [psi]
15-3	› 15-12	145 [psi]
<b>CR(E), CRI(E), CRN(E) 20</b>		
20-1		116 [psi]
20-2	› 20-10	145 [psi]
<b>CR(E), CRN(E) 32</b>		
32-1-1	› 32-2	58 [psi]
32-3-2	› 32-6	145 [psi]
32-7-2	› 32-11-2	218 [psi]
<b>CR(E), CRN(E) 45</b>		
45-1-1	› 45-1	58 [psi]
45-2-2	› 45-3	145 [psi]
45-4-2	› 45-8-1	218 [psi]
<b>CR(E), CRN(E) 64</b>		
64-1-1		58 [psi]
64-1	› 64-2-1	145 [psi]
64-2	› 64-5-2	218 [psi]
<b>CR(E), CRN(E) 90</b>		
90-1-1	› 90-2-2	145 [psi]
90-2-1	› 90-4-1	218 [psi]
<b>CR(E), CRN(E) 120</b>		
120-1		145 [psi]
120-2-2	› 120-3	218 [psi]
120-4-2	› 120-5-1	290 [psi]
<b>CR(E), CRN(E) 150</b>		
150-1-1		145 [psi]
150-1	› 150-2	218 [psi]
150-3-2	› 150-4-1	290 [psi]

## Example of operating and inlet pressures

The values for operating and inlet pressures shown in the tables must not be considered individually but must always be compared, see the following examples:

### Example 1:

The following pump type has been selected:  
CR 3-10 A-A-A

Max. operating pressure: **232 psi**

Max. inlet pressure: **145 psi**

Discharge pressure against a closed valve: **139.2 psi**, see page 34.

This pump is not allowed to start at an inlet pressure of 145 psi, but at an inlet pressure of  $232.0 - 139.2 =$  **92.8 psi**.

### Example 2:

The following pump has been selected:  
CR 10-2 A-GJ-A

Max. operating pressure: **232 psi**

Max. inlet pressure: **116 psi**

Discharge pressure against a closed valve: **42 psi (97 ft)**, see page 42.

This pump is allowed to start at an inlet pressure of 116 psi, as the discharge pressure is only 42 psi, which results in an operating pressure of  $116 + 42 =$  **158 psi**. On the contrary, the max. operating pressure of this pump is limited to 158 psi, as a higher operating pressure will require an inlet pressure of more than 116 psi.

In case the inlet or operating pressure exceeds the pressure permitted, see section *Lists of variants - on request* on page 83.



## Selection of pumps

Selection of pumps should be based on

- The duty point of the pump (see section 1)
- Sizing data such as pressure loss as a result of height differences, friction loss in the pipework, pump efficiency etc. (see section 2)
- Pump materials (see section 3)
- Pump connections (see section 4)
- Shaft seal (see section 5).

### 1. Duty point of the pump

From a duty point it is possible to select a pump on the basis of the curve charts in the section *Performance curves/Technical data* starting on page 26.

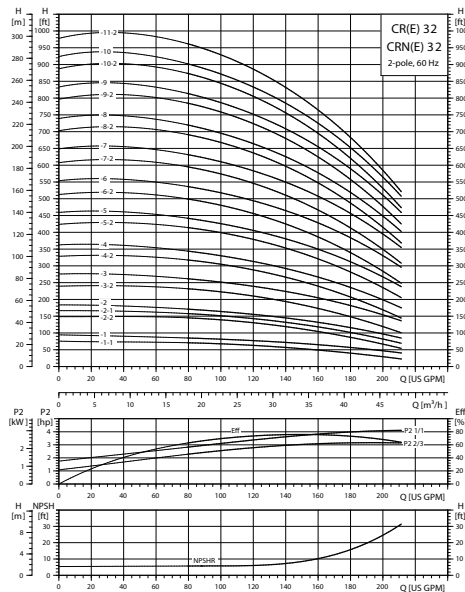

Fig. 17 Example of a curve chart

### 2. Sizing data

When sizing a pump the following must be taken into account.

- Required flow and pressure at the point of use.
- Pressure loss as a result of height differences ( $H_{geo}$ ).
- Friction loss in the pipework ( $H_f$ ).  
It may be necessary to account for pressure loss in connection with long pipes, bends or valves, etc.
- Best efficiency at the estimated duty point.
- NPSH value.  
For calculation of the NPSH value, see *Minimum inlet pressure - NPSHA* on page 24.

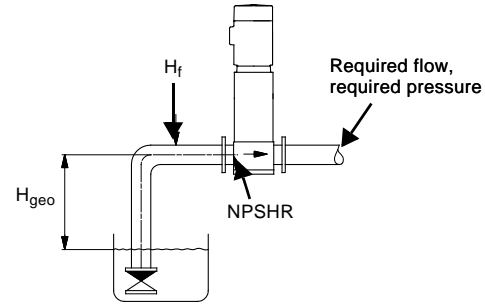

Fig. 18 Sizing data

### Efficiency

Before determining the point of best efficiency the operation pattern of the pump needs to be identified. Is the pump expected to operate at the same duty point, then select a CR pump which is operating at a duty point corresponding with the best efficiency of the pump.

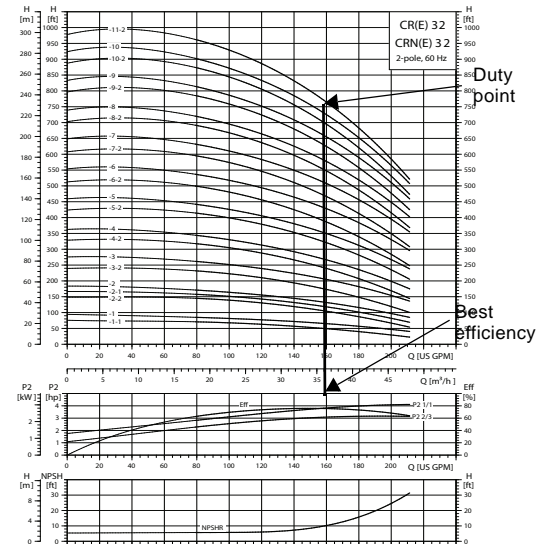

Fig. 19 Example of a CR pump's duty point

As the pump is sized on the basis of the highest possible flow, it is important to always have the duty point to the right of the optimum efficiency point (see fig. 20, range with check mark). This must be considered in order to keep efficiency high when the flow drops.

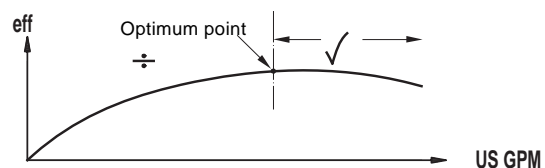

Fig. 20 Best efficiency

TM02 6711 1403

TM02 0039 1303

TM02 0039 1303

TM02 8579 0504

Normally, E-pumps are used in applications characterized by a variable flow. Consequently, it is not possible to select a pump that is constantly operating at optimum efficiency.

In order to achieve optimum operating economy, the pump should be selected on the basis of the following criteria:

- The max. required duty point should be as close as possible to the QH curve of the pump.
- The required duty point should be positioned so that P2 is close to the max. point of the 100 % curve.

Between the min. and max. performance curve E-pumps have an infinite number of performance curves each representing a specific speed. Therefore it may not be possible to select a duty point close to the 100 % curve.

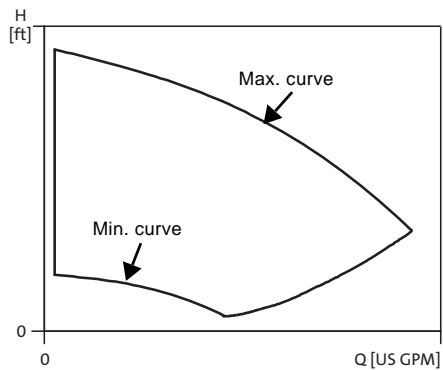

TM02 7572 4803

Fig. 21 Min. and max. performance curves

In situations where it is not possible to select a duty point close to the 100 % curve the affinity equations to the right can be used. The head (H), the flow (Q) and the input power (P) are all the appropriate variables for the motor speed (n).

**Note:**

The approximated formulas apply on condition that the system characteristic remains unchanged for  $n_n$  and  $n_x$  and that it is based on the formula  $H = k \times Q^2$ , where  $k$  is a constant.

The power equation implies that the pump efficiency is unchanged at the two speeds. In practice this is **not** quite correct.

Finally, it is worth noting that the efficiencies of the frequency converter and the motor **must** be taken into account if a precise calculation of the power saving resulting from a reduction of the pump speed is wanted.

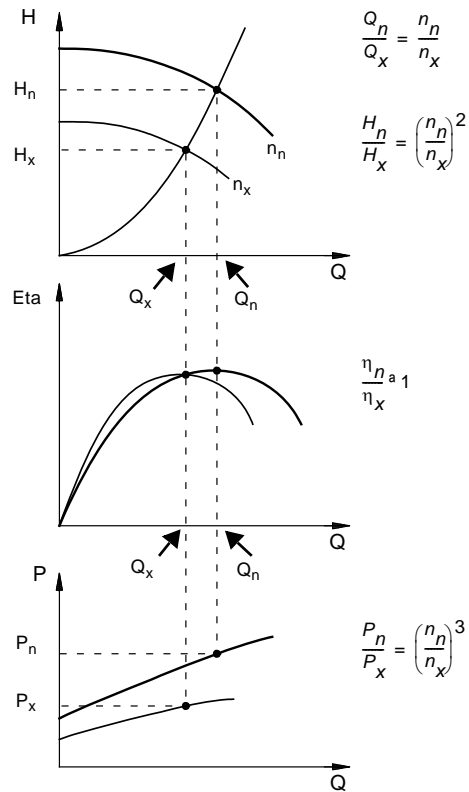

TM00 8720 3496

Fig. 22 Affinity equations

**Legend**

$H_n$	Rated head in feet
$H_x$	Current head in feet
$Q_n$	Rated flow in US GPM
$Q_x$	Current flow in US GPM
$n_n$	Rated motor speed in $\text{min}^{-1}$ ( $n_n = 3500 \text{ min}^{-1}$ )
$n_x$	Current motor speed in $\text{min}^{-1}$
$\eta_n$	Rated efficiency in %
$\eta_x$	Current efficiency in %

## WinCAPS and WebCAPS

WinCAPS and WebCAPS are both selection programs offered by Grundfos.

The two programs make it possible to calculate an E-pump's specific duty point and energy consumption.

By entering the sizing data of the pump, WinCAPS and WebCAPS can calculate the exact duty point and energy consumption. For further information see page 89 and page 90.

## 3. Material

The material variant (CR(E), CRI(E), CRN(E)) should be selected based of the liquid to be pumped. The product range covers three basic types.

- The CR(E), CRI(E) pump types are suitable for clean, non-aggressive liquids such as potable water, oils, etc.
- The CRN(E) pump type is suitable for industrial liquids and acids, see *List of pumped liquids* on page 74 or contact Grundfos.

For saline or chloride-containing liquids such as sea water, CRT(E) pumps of titanium are available.

## 4. Pump connection

Selection of pump connection depends on the rated pressure and pipework. To meet any requirement the CR(E), CRI(E) and CRN(E) pumps offer a wide range of flexible connections such as:

- Oval flange (NPT) - fig. 24
- ANSI flange - fig. 24
- PJE coupling - fig. 24
- Clamp coupling
- Union (NPT[M])
- Other connections on request.

## 5. Shaft seal

As standard, the CR(E) range is fitted with a Grundfos shaft seal (Cartridge type) suitable for the most common applications, see fig. 25.

The following three key parameters **must** be taken into account, when selecting the shaft seal:

- Type of pumped liquid
- liquid temperature and
- Maximum pressure.

Grundfos offers a wide range of shaft seal variants to meet specific demands see *List of pumped liquids* on page 74.

## 6. Inlet pressure and operating pressure

Do **not** exceed the limit values stated on page 18 and page 20 as regards these pressures:

- maximum inlet pressure and
- maximum operating pressure.

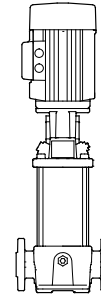

Fig. 23 CR pump

TM03 2155 3805

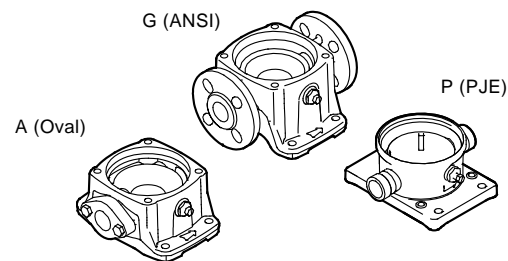

Fig. 24 Pump connections

TM02 1201 0601

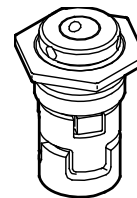

Fig. 25 Shaft seal (Cartridge type)

TM02 0538 4800

## Minimum inlet pressure - NPSHA

Calculation of the inlet pressure "H" is recommended in these situations:

- The liquid temperature is high,
- The flow is significantly higher than the rated flow,
- Water is drawn from depths,
- Water is drawn through long pipes,
- Inlet conditions are poor.

To avoid cavitation, make sure that there is a minimum pressure on the suction side of the pump. The maximum suction lift "H" in feet can be calculated as follows:

$$H = p_b - \text{NPSHR} - H_f - H_v - H_s$$

$P_b$  = Barometric pressure in feet absolute.  
(Barometric pressure can be set to 33.9 feet. At sea level. In closed systems,  $p_b$  indicates system pressure in feet.)

**NPSHR** = Net Positive Suction Head Required in feet.  
(To be read from the NPSHR curve at the highest flow the pump will be delivering).

$H_f$  = Friction loss in suction pipe in feet.  
(At the highest flow the pump will be delivering.)

$H_v$  = Vapor pressure in feet. (To be read from the vapor pressure scale. " $H_v$ " depends on the liquid temperature " $T_m$ ").

$H_s$  = Safety margin = minimum 2.0 feet.

If the "H" calculated is positive, the pump can operate at a suction lift of maximum "H" feet.

If the "H" calculated is negative, an inlet pressure of minimum "H" feet is required.

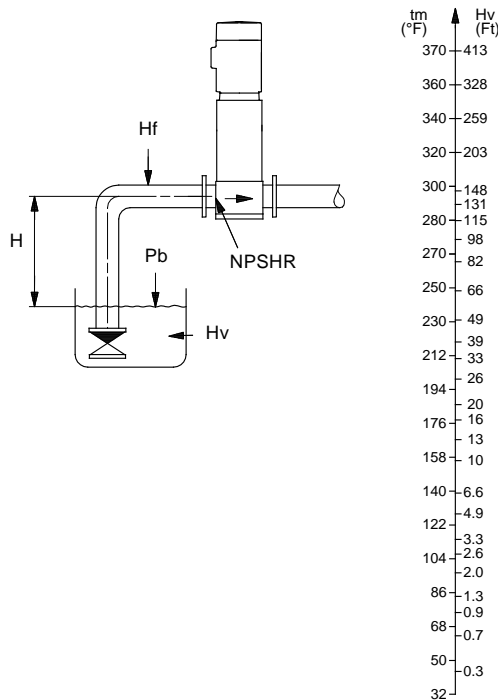

**Fig. 26** Minimum inlet pressure - NPSHR

**Note:** In order to avoid cavitation **never**, select a pump whose duty point lies too far to the right on the NPSHR curve.

Always check the NPSHR value of the pump at the highest possible flow.

In case a lower NPSHR value is required, see *Lists of variants - on request* on page 83.

TM02 7729 3903

## How to read the curve charts

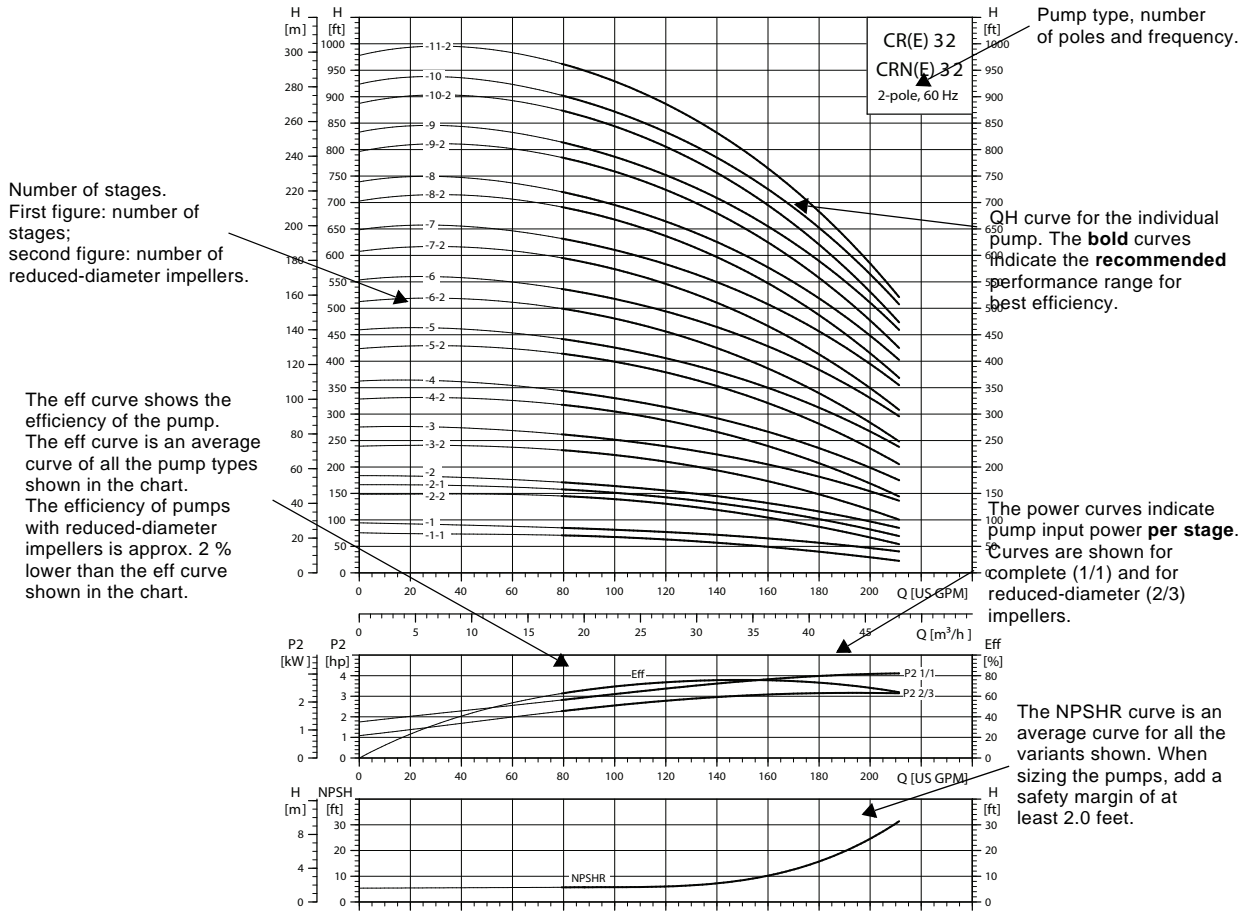

Fig. 27 How to read the curve charts

## Guidelines to performance curves

The guidelines below apply to the curves shown on the following pages:

1. The motors used for the measurements are standard motors (ODP, TEFC or MLE).
2. Measurements have been made with airless water at a temperature of 68 °F.
3. The curves apply to a kinematic viscosity of  $\nu = 1 \text{ mm}^2/\text{s}$  (1 cSt).
4. Due to the risk of overheating, the pumps should not be used at a flow below the minimum flow rate.
5. The QH curves apply to actual speed with the motor types mentioned at 60 Hz.

The curve below shows the minimum flow rate as a percentage of the nominal flow rate in relation to the liquid temperature. The dotted line shows a CR pump fitted with an air-cooled top assembly.

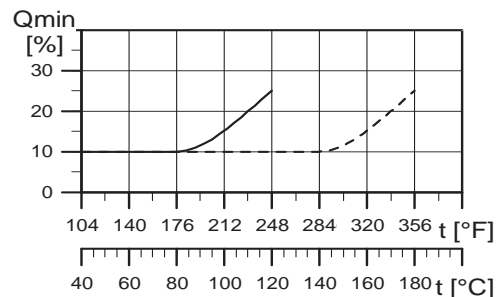

Fig. 28 Minimum flow rate

TM02 0039 1303

TM02 7538 3703

# Performance curves/ Technical data

CR 1s, CRI 1s, CRN 1s

## CR, CRI, CRN 1s

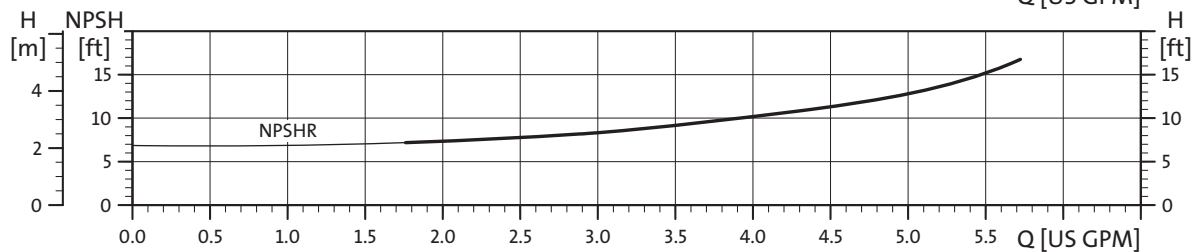
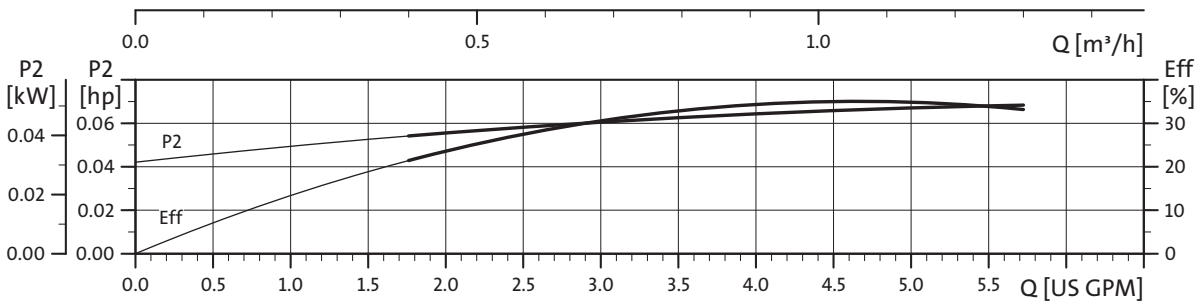
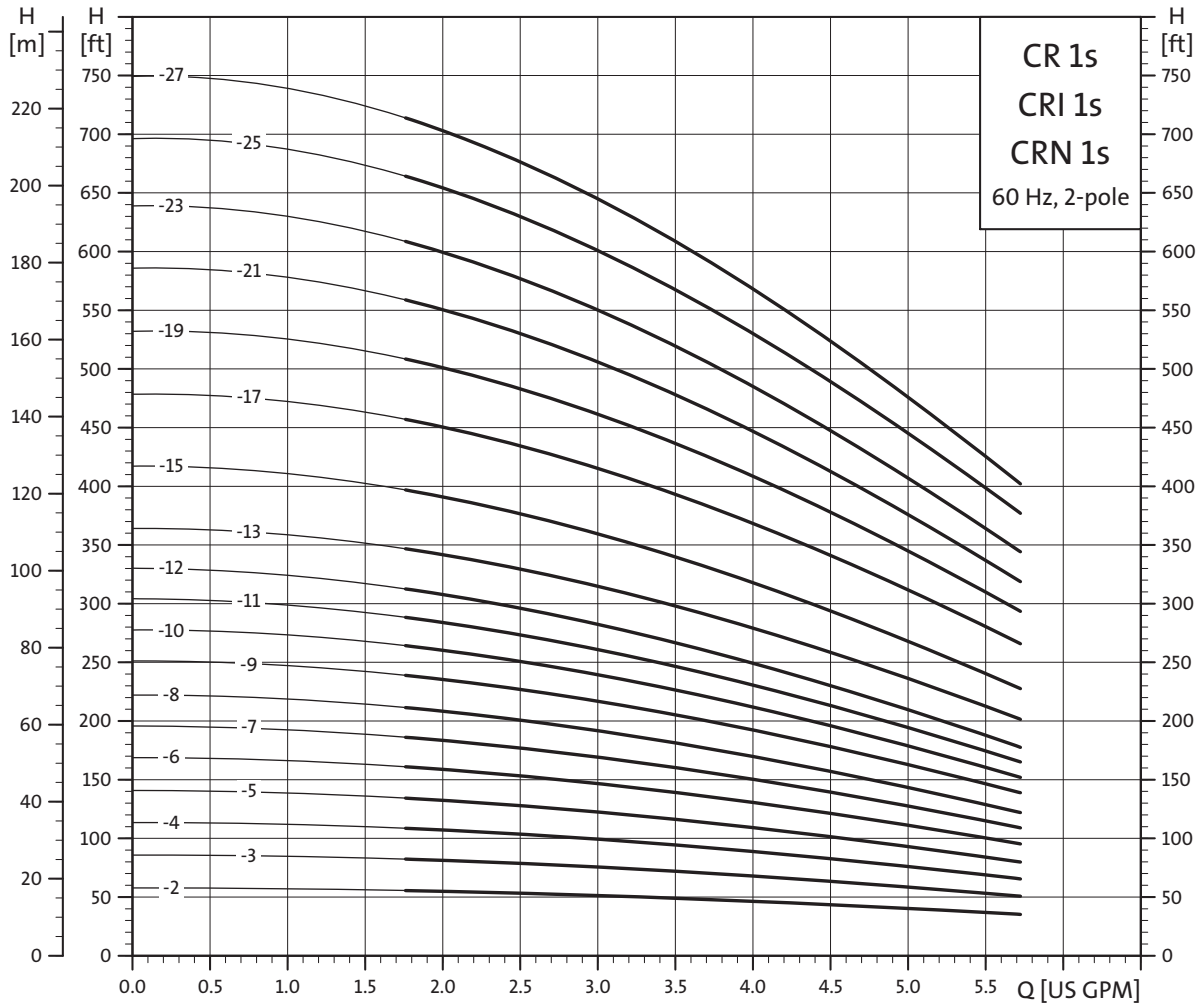

TM02 5741 1303

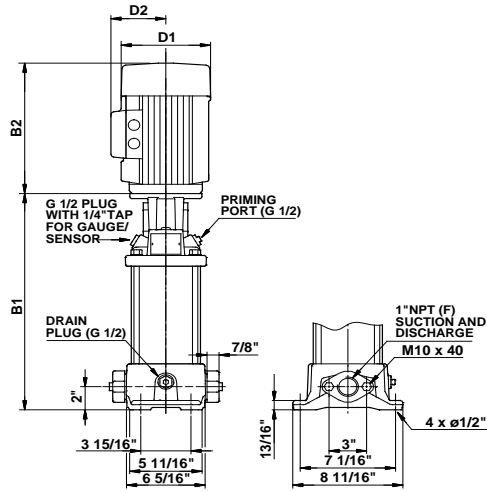

TM03 1450 2205

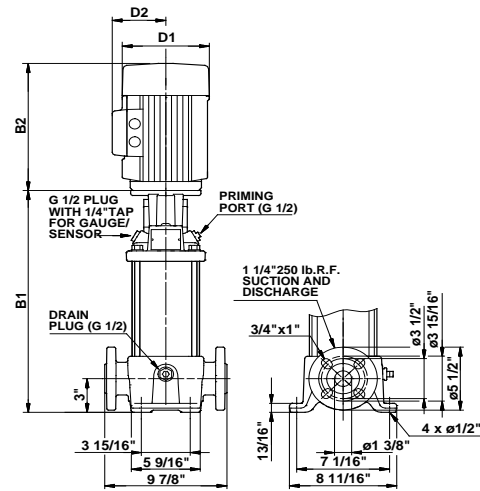

TM03 1451 2205

Pump type	P2 [hp]	Ph.	Oval*	ANSI dimensions [inch]				Ship Wt. [lbs.]
				B1	TEFC		B1+B2	
					D1	D2		
CR 1s-2	1/3	1	•	11.97	6.19	5.18	21.26	69
		3	•	11.97	5.55	4.57	19.41	67
CR 1s-3	1/3	1	•	11.97	6.19	5.18	21.26	69
		3	•	11.97	5.55	4.57	19.41	67
CR 1s-4	1/3	1	•	12.68	6.19	5.18	21.97	70
		3	•	12.68	5.55	4.57	20.12	68
CR 1s-5	1/3	1	•	13.39	6.19	5.18	22.68	71
		3	•	13.39	5.55	4.57	20.83	69
CR 1s-6	1/2	1	•	14.09	6.19	5.18	23.38	75
		3	•	14.09	5.55	4.57	21.53	70
CR 1s-7	1/2	1	•	14.80	6.19	5.18	24.09	76
		3	•	14.80	5.55	4.57	22.24	71
CR 1s-8	1/2	1	•	15.51	6.19	5.18	24.80	77
		3	•	15.51	5.55	4.57	22.95	72
CR 1s-9	3/4	1	•	16.22	6.19	5.18	26.13	82
		3	•	16.22	5.55	4.57	23.66	73
CR 1s-10	3/4	1	•	16.93	6.19	5.18	26.84	83
		3	•	16.93	5.55	4.57	24.37	74
CR 1s-11	3/4	1	•	17.64	6.19	5.18	27.55	84
		3	•	17.64	5.55	4.57	25.08	75
CR 1s-12	3/4	1	•	18.35	6.19	5.18	28.26	85
		3	•	18.35	5.55	4.57	25.79	76
CR 1s-13	1	1	•	19.06	7.19	5.73	30.25	101
		3	•	19.06	5.55	4.57	26.50	77
CR 1s-15	1	1	•	20.47	7.19	5.73	31.66	103
		3	•	20.47	5.55	4.57	27.91	78
CR 1s-17	1 1/2	1	•	21.89	7.19	5.73	33.57	107
		3	•	21.89	5.55	4.57	30.51	84
CR 1s-19	1 1/2	1	-	23.31	7.19	5.73	34.99	109
		3	-	23.31	5.55	4.57	31.93	86
CR 1s-21	1 1/2	1	-	24.72	7.19	5.73	36.40	111
		3	-	24.72	5.55	4.57	33.34	88
CR 1s-23	1 1/2	1	-	26.14	7.19	5.73	37.82	113
		3	-	26.14	5.55	4.57	34.76	90
CR 1s-25	2	1	-	27.56	7.19	5.73	40.12	126
		3	-	27.56	7.01	4.33	38.78	116
CR 1s-27	2	1	-	28.98	7.19	5.73	41.54	127
		3	-	28.98	7.01	4.33	40.20	118

All dimensions in inches unless otherwise noted.

\*Oval flanged pump B1 and B1+B2 dimension is one inch less than ANSI flanged pump and weight is approximately 9 lbs. less.

• Available

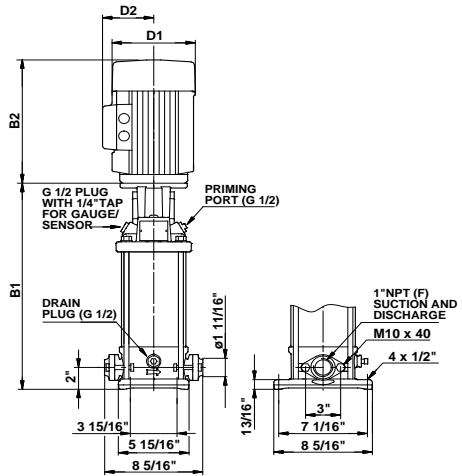

TM03 1452 2205

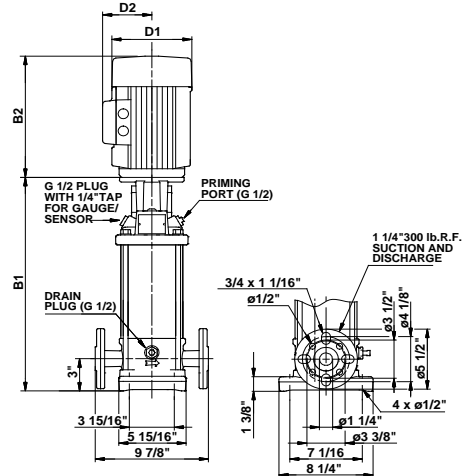

TM03 1453 2205

Pump type	P2 [hp]	Ph.	Oval*	ANSI dimensions [inch]				Ship Wt. [lbs.]
				B1	TEFC			
					D1	D2	B1+B2	
CRI 1s-2	1/3	1	•	12.09	6.19	5.18	21.38	64
		3	•	12.09	5.55	4.57	19.53	62
CRI 1s-3	1/3	1	•	12.09	6.19	5.18	21.38	64
		3	•	12.09	5.55	4.57	19.53	62
CRI 1s-4	1/3	1	•	12.80	6.19	5.18	22.09	65
		3	•	12.80	5.55	4.57	20.24	63
CRI 1s-5	1/3	1	•	13.50	6.19	5.18	22.79	66
		3	•	13.50	5.55	4.57	20.94	64
CRI 1s-6	1/2	1	•	14.21	6.19	5.18	23.50	70
		3	•	14.21	5.55	4.57	21.65	65
CRI 1s-7	1/2	1	•	14.92	6.19	5.18	24.21	71
		3	•	14.92	5.55	4.57	22.36	65
CRI 1s-8	1/2	1	•	15.63	6.19	5.18	24.92	72
		3	•	15.63	5.55	4.57	23.07	66
CRI 1s-9	3/4	1	•	16.34	6.19	5.18	26.25	77
		3	•	16.34	5.55	4.57	23.78	68
CRI 1s-10	3/4	1	•	17.05	6.19	5.18	26.96	78
		3	•	17.05	5.55	4.57	24.49	69
CRI 1s-11	3/4	1	•	17.76	6.19	5.18	27.67	79
		3	•	17.76	5.55	4.57	25.20	70
CRI 1s-12	3/4	1	•	18.46	6.19	5.18	28.37	79
		3	•	18.46	5.55	4.57	25.90	70
CRI 1s-13	1	1	•	19.17	7.19	5.73	30.36	96
		3	•	19.17	5.55	4.57	26.61	71
CRI 1s-15	1	1	•	20.59	7.19	5.73	31.78	97
		3	•	20.59	5.55	4.57	28.03	73
CRI 1s-17	1 1/2	1	•	22.01	7.19	5.73	33.69	102
		3	•	22.01	5.55	4.57	30.63	79
CRI 1s-19	1 1/2	1	-	23.43	7.19	5.73	35.11	104
		3	-	23.43	5.55	4.57	32.05	81
CRI 1s-21	1 1/2	1	-	24.84	7.19	5.73	36.52	106
		3	-	24.84	5.55	4.57	33.46	82
CRI 1s-23	1 1/2	1	-	26.26	7.19	5.73	37.94	107
		3	-	26.26	5.55	4.57	34.88	84
CRI 1s-25	2	1	-	27.68	7.19	5.73	40.24	120
		3	-	27.68	7.01	4.33	38.90	111
CRI 1s-27	2	1	-	29.09	7.19	5.73	41.65	122
		3	-	29.09	7.01	4.33	40.31	113

All dimensions in inches unless otherwise noted.

\*Oval flanged pump B1 and B1+B2 dimension is one inch less than ANSI flanged pump and weight is approximately 9 lbs. less.

• Available.



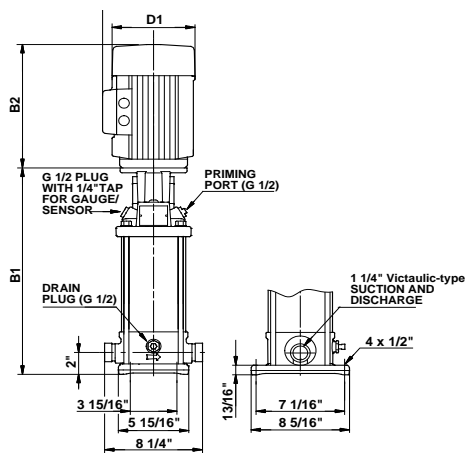

TM03 1454 2205

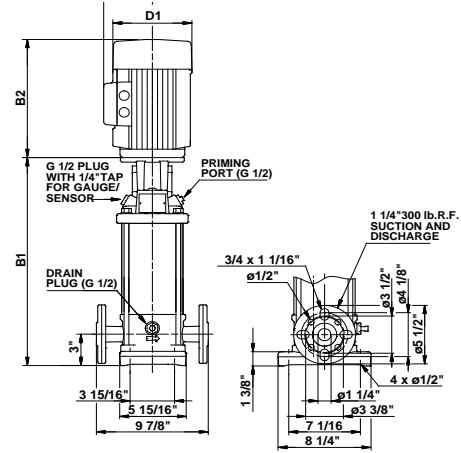

TM03 1453 2205

Pump type	P2 [hp]	Ph.	PJE*	ANSI dimensions [inch]				Ship Wt. [lbs.]
				B1	TEFC			
					D1	D2	B1+B2	
CRN 1s-2	1/3	1	•	12.09	6.19	5.18	21.38	63
		3	•	12.09	5.55	4.57	19.53	61
CRN 1s-3	1/3	1	•	12.09	6.19	5.18	21.38	64
		3	•	12.09	5.55	4.57	19.53	62
CRN 1s-4	1/3	1	•	12.80	6.19	5.18	22.09	65
		3	•	12.80	5.55	4.57	20.24	63
CRN 1s-5	1/3	1	•	13.50	6.19	5.18	22.79	66
		3	•	13.50	5.55	4.57	20.94	64
CRN 1s-6	1/2	1	•	14.21	6.19	5.18	23.50	70
		3	•	14.21	5.55	4.57	21.65	65
CRN 1s-7	1/2	1	•	14.92	6.19	5.18	24.21	71
		3	•	14.92	5.55	4.57	22.36	65
CRN 1s-8	1/2	1	•	15.63	6.19	5.18	24.92	72
		3	•	15.63	5.55	4.57	23.07	66
CRN 1s-9	3/4	1	•	16.34	6.19	5.18	26.25	77
		3	•	16.34	5.55	4.57	23.78	68
CRN 1s-10	3/4	1	•	17.05	6.19	5.18	26.96	78
		3	•	17.05	5.55	4.57	24.49	69
CRN 1s-11	3/4	1	•	17.76	6.19	5.18	27.67	78
		3	•	17.76	5.55	4.57	25.20	69
CRN 1s-12	3/4	1	•	18.46	6.19	5.18	28.37	79
		3	•	18.46	5.55	4.57	25.90	70
CRN 1s-13	1	1	•	19.17	7.19	5.73	30.36	96
		3	•	19.17	5.55	4.57	26.61	71
CRN 1s-15	1	1	•	20.59	7.19	5.73	31.78	97
		3	•	20.59	5.55	4.57	28.03	73
CRN 1s-17	1 1/2	1	•	22.01	7.19	5.73	33.69	102
		3	•	22.01	5.55	4.57	30.63	79
CRN 1s-19	1 1/2	1	•	23.43	7.19	5.73	35.11	104
		3	•	23.43	5.55	4.57	32.05	81
CRN 1s-21	1 1/2	1	•	24.84	7.19	5.73	36.52	105
		3	•	24.84	5.55	4.57	33.46	82
CRN 1s-23	1 1/2	1	•	26.26	7.19	5.73	37.94	107
		3	•	26.26	5.55	4.57	34.88	84
CRN 1s-25	2	1	•	27.68	7.19	5.73	40.24	120
		3	•	27.68	7.01	4.33	38.90	111
CRN 1s-27	2	1	•	29.09	7.19	5.73	41.65	122
		3	•	29.09	7.01	4.33	40.31	112

All dimensions in inches unless otherwise noted.

\*PJE flanged pump B1 and B1+B2 dimension is one inch less than ANSI flanged pump and weight is approximately 9 lbs. less.

• Available.

## CR(E), CRI(E), CRN(E) 1

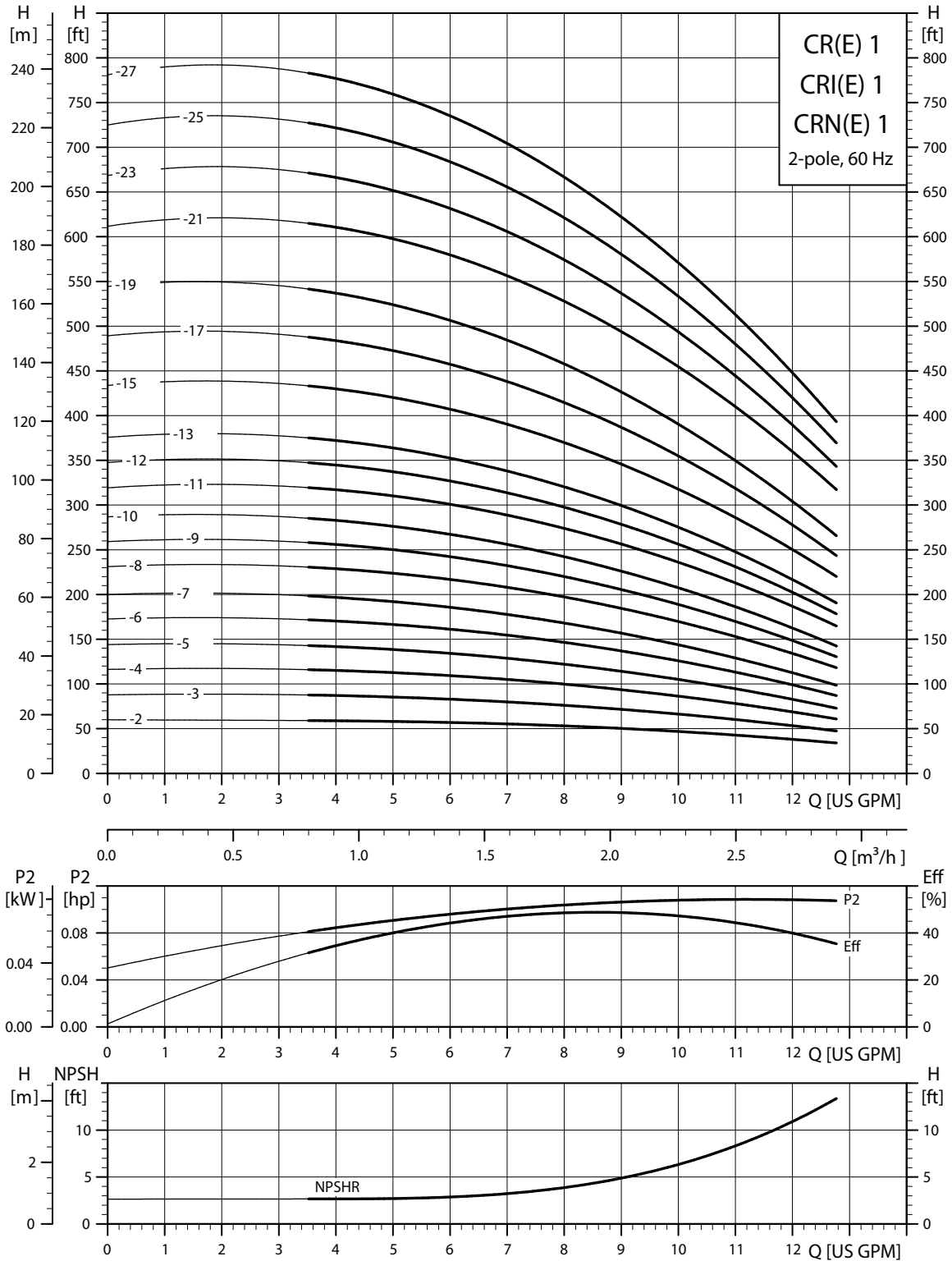

TM02 4083 1303

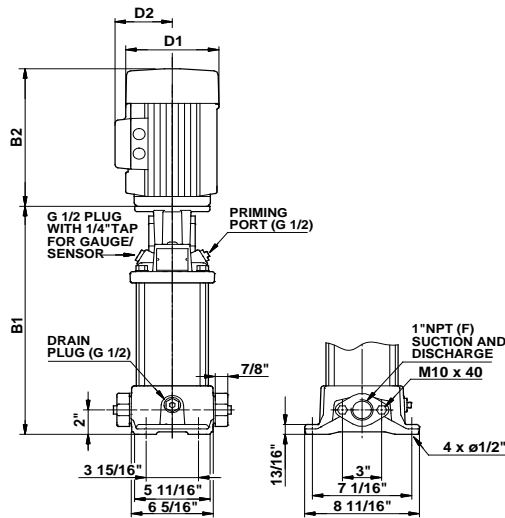

TM03 1450 2205

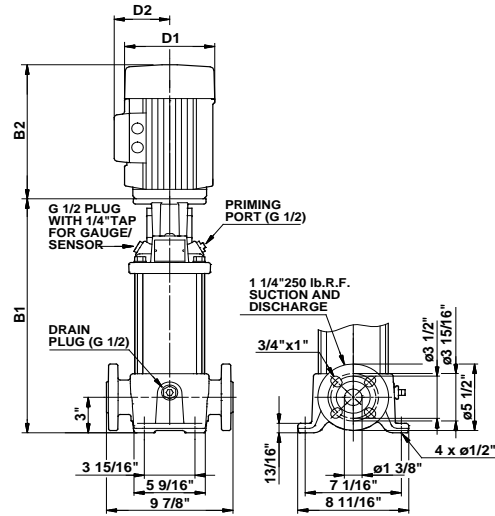

TM03 1451 2205

Pump type	P2 [hp]	Ph.	Oval*	ANSI dimensions [inch]				Ship Wt. [lbs.]	ANSI dimensions [inch]				Ship Wt. [lbs.]
				B1	TEFC				MLE				
					D1	D2	B1+B2		D1	D2	B1+B2		
CR 1-2	1/3	1	•	11.97	6.19	5.18	21.26	69	-	-	-	-	-
		3	•	11.97	5.55	4.57	19.41	67	-	-	-	-	-
CR 1-3	1/3	1	•	11.97	6.19	5.18	21.26	69	-	-	-	-	-
		3	•	11.97	5.55	4.57	19.41	67	-	-	-	-	-
CR(E) 1-4	1/2	1	•	12.68	6.19	5.18	21.97	73	5.55	5.51	20.10	71	-
		3	•	12.68	5.55	4.57	20.12	68	-	-	-	-	-
CR 1-5	1/2	1	•	13.39	6.19	5.18	22.68	75	-	-	-	-	-
		3	•	13.39	5.55	4.57	20.83	69	-	-	-	-	-
CR(E) 1-6	3/4	1	•	14.09	6.19	5.18	24.00	80	5.55	5.51	21.51	74	-
		3	•	14.09	5.55	4.57	21.53	71	-	-	-	-	-
CR 1-7	3/4	1	•	14.80	6.19	5.18	24.71	81	-	-	-	-	-
		3	•	14.80	5.55	4.57	22.24	72	-	-	-	-	-
CR 1-8	1	1	•	15.51	7.19	5.73	26.70	93	-	-	-	-	-
		3	•	15.51	5.55	4.57	22.95	72	-	-	-	-	-
CR(E) 1-9	1	1	•	16.22	7.19	5.73	27.41	94	5.55	5.51	25.20	79	-
		3	•	16.22	5.55	4.57	23.66	74	7.01	6.57	29.02	96	-
CR(E) 1-10	1 1/2	1	•	16.93	7.19	5.73	28.61	95	-	-	-	-	-
		3	•	16.93	5.55	4.57	25.55	74	7.01	6.57	29.73	99	-
CR 1-11	1 1/2	1	•	17.64	7.19	5.73	29.32	102	-	-	-	-	-
		3	•	17.64	5.55	4.57	26.26	76	-	-	-	-	-
CR 1-12	1 1/2	1	•	18.35	7.19	5.73	30.03	103	-	-	-	-	-
		3	•	18.35	5.55	4.57	26.97	77	-	-	-	-	-
CR(E) 1-13	1 1/2	1	•	19.06	7.19	5.73	30.74	104	5.55	5.51	28.04	86	-
		3	•	19.06	5.55	4.57	27.68	78	7.01	6.57	31.86	102	-
CR(E) 1-15	2	1	•	20.47	7.19	5.73	33.03	114	-	-	-	-	-
		3	•	20.47	7.01	4.33	31.69	104	7.01	6.57	33.27	117	-
CR(E) 1-17	2	1	•	21.89	7.19	5.73	34.45	116	-	-	-	-	-
		3	•	21.89	7.01	4.33	33.11	106	7.01	6.57	34.69	119	-
CR 1-19	3	1	-	24.41	8.60	6.87	39.06	155	-	-	-	-	-
		3	-	24.41	7.01	4.33	37.64	123	-	-	-	-	-
CR 1-21	3	1	-	25.83	8.60	6.87	40.48	158	-	-	-	-	-
		3	-	25.83	7.01	4.33	39.06	125	-	-	-	-	-
CR(E) 1-23	3	1	-	27.24	8.60	6.87	41.89	159	-	-	-	-	-
		3	-	27.24	7.01	4.33	40.47	130	7.01	6.57	40.55	139	-
CR 1-25	3	1	-	28.66	8.60	6.87	43.31	161	-	-	-	-	-
		3	-	28.66	7.01	4.33	41.89	132	-	-	-	-	-
CR(E) 1-27	3	1	-	30.08	8.60	6.87	44.73	163	-	-	-	-	-
		3	-	30.08	7.01	4.33	43.31	134	7.01	6.57	43.39	142	-

All dimensions in inches unless otherwise noted.

\*Oval flanged pump B1 and B1+B2 dimension is one inch less than ANSI flanged pump and weight is approximately 9 lbs. less.

• Available.

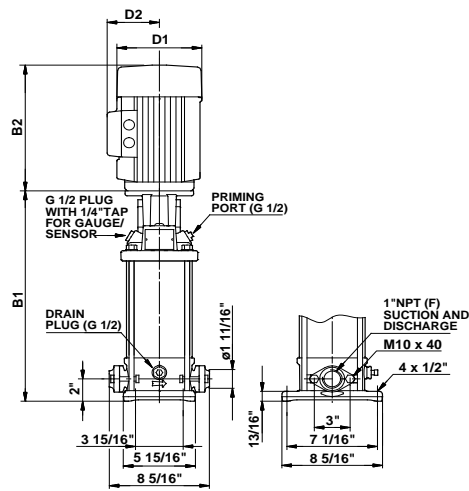

TM03 1450 2205

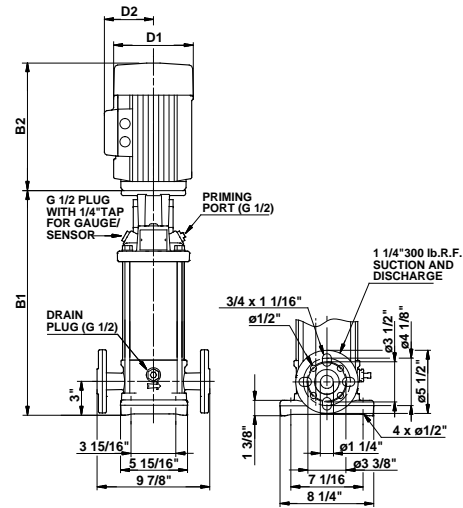

TM03 1451 2205.

Pump type	P2 [hp]	Ph.	Oval*	ANSI dimensions [inch]				Ship Wt. [lbs.]	ANSI dimensions [inch]			Ship Wt. [lbs.]
				B1	TEFC				MLE			
					D1	D2	B1+B2		D1	D2	B1+B2	
CRI 1-2	1/3	1	•	12.09	6.19	5.18	21.38	64	-	-	-	-
		3	•	12.09	5.55	4.57	19.53	62	-	-	-	-
CRI 1-3	1/3	1	•	12.09	6.19	5.18	21.38	64	-	-	-	-
		3	•	12.09	5.55	4.57	19.53	62	-	-	-	-
CRI(E) 1-4	1/2	1	•	12.8	6.19	5.18	22.09	68	5.55	5.51	20.22	65
		3	•	12.8	5.55	4.57	20.24	63	-	-	-	-
CRI 1-5	1/2	1	•	13.5	6.19	5.18	22.79	69	-	-	-	-
		3	•	13.5	5.55	4.57	20.94	64	-	-	-	-
CRI(E) 1-6	3/4	1	•	14.21	6.19	5.18	24.12	74	5.55	5.51	21.63	68
		3	•	14.21	5.55	4.57	21.65	65	-	-	-	-
CRI 1-7	3/4	1	•	14.92	6.19	5.18	24.83	75	-	-	-	-
		3	•	14.92	5.55	4.57	22.36	66	-	-	-	-
CRI 1-8	1	1	•	15.63	7.19	5.73	26.82	88	-	-	-	-
		3	•	15.63	5.55	4.57	23.07	67	-	-	-	-
CRI(E) 1-9	1	1	•	16.34	7.19	5.73	27.53	89	5.55	5.51	25.32	73
		3	•	16.34	5.55	4.57	23.78	68	7.01	6.57	29.14	90
CRI(E) 1-10	1 1/2	1	•	17.05	7.19	5.73	28.73	90	-	-	-	-
		3	•	17.05	5.55	4.57	25.67	69	7.01	6.57	29.85	92
CRI 1-11	1 1/2	1	•	17.76	7.19	5.73	29.44	97	-	-	-	-
		3	•	17.76	5.55	4.57	26.38	70	-	-	-	-
CRI 1-12	1 1/2	1	•	18.46	7.19	5.73	30.14	98	-	-	-	-
		3	•	18.46	5.55	4.57	27.08	71	-	-	-	-
CRI(E) 1-13	1 1/2	1	•	19.17	7.19	5.73	30.85	99	5.55	5.51	28.15	80
		3	•	19.17	5.55	4.57	27.79	72	7.01	6.57	31.97	97
CRI(E) 1-15	2	1	•	20.59	7.19	5.73	33.15	109	-	-	-	-
		3	•	20.59	7.01	4.33	31.81	99	7.01	6.57	33.39	112
CRI(E) 1-17	2	1	•	22.01	7.19	5.73	34.57	110	-	-	-	-
		3	•	22.01	7.01	4.33	33.23	101	7.01	6.57	34.81	113
CRI 1-19	3	1	-	24.53	8.60	6.87	39.18	148	-	-	-	-
		3	-	24.53	7.01	4.33	37.76	116	-	-	-	-
CRI 1-21	3	1	-	25.94	8.60	6.87	40.59	150	-	-	-	-
		3	-	25.94	7.01	4.33	39.17	118	-	-	-	-
CRI(E) 1-23	3	1	-	27.36	8.60	6.87	42.01	152	-	-	-	-
		3	-	27.36	7.01	4.33	40.59	123	7.01	6.57	40.67	131
CRI 1-25	3	1	-	28.78	8.60	6.87	43.43	154	-	-	-	-
		3	-	28.78	7.01	4.33	42.01	125	-	-	-	-
CRI(E) 1-27	3	1	-	30.20	8.60	6.87	44.85	156	-	-	-	-
		3	-	30.20	7.01	4.33	43.43	127	7.01	6.57	43.51	135

All dimensions in inches unless otherwise noted.

\*Oval flanged pump B1 and B1+B2 dimension is one inch less than ANSI flanged pump and weight is approximately 9 lbs. less.

• Available.

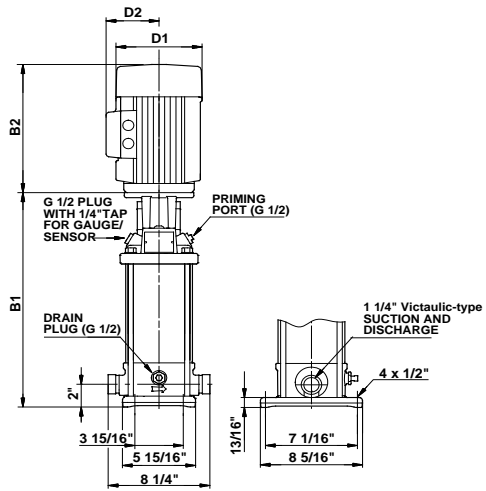

TM03 1454 2205

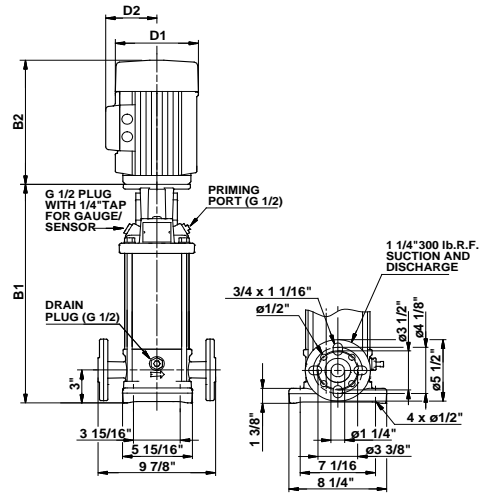

TM03 1453 2205

Pump type	P2 [hp]	Ph.	PJE*	ANSI dimensions [inch]				Ship Wt. [lbs.]	ANSI dimensions [inch]				
				B1	TEFC		B1+B2		MLE			Ship Wt. [lbs.]	
					D1	D2			D1	D2	B1+B2		
CRN 1-2	1/3	1	•	12.09	6.19	5.18	21.38	64	-	-	-	-	-
		3	•	12.09	5.55	4.57	19.53	62	-	-	-	-	-
CRN 1-3	1/3	1	•	12.09	6.19	5.18	21.38	64	-	-	-	-	-
		3	•	12.09	5.55	4.57	19.53	62	-	-	-	-	-
CRN(E) 1-4	1/2	1	•	12.80	6.19	5.18	22.09	68	5.55	5.51	20.22	65	-
		3	•	12.80	5.55	4.57	20.24	63	-	-	-	-	-
CRN 1-5	1/2	1	•	13.50	6.19	5.18	22.79	69	-	-	-	-	-
		3	•	13.50	5.55	4.57	20.94	64	-	-	-	-	-
CRN(E) 1-6	3/4	1	•	14.21	6.19	5.18	24.12	74	5.55	5.51	21.63	68	-
		3	•	14.21	5.55	4.57	21.65	65	-	-	-	-	-
CRN 1-7	3/4	1	•	14.92	6.19	5.18	24.83	75	-	-	-	-	-
		3	•	14.92	5.55	4.57	22.36	66	-	-	-	-	-
CRN 1-8	1	1	•	15.63	7.19	5.73	26.82	88	-	-	-	-	-
		3	•	15.63	5.55	4.57	23.07	67	-	-	-	-	-
CRN(E) 1-9	1	1	•	16.34	7.19	5.73	27.53	89	5.55	5.51	25.32	73	-
		3	•	16.34	5.55	4.57	23.78	68	7.01	6.57	29.14	90	-
CRN(E) 1-10	1 1/2	1	•	17.05	7.19	5.73	28.73	90	-	-	-	-	-
		3	•	17.05	5.55	4.57	25.67	69	7.01	6.57	29.85	92	-
CRN 1-11	1 1/2	1	•	17.76	7.19	5.73	29.44	97	-	-	-	-	-
		3	•	17.76	5.55	4.57	26.38	70	-	-	-	-	-
CRN 1-12	1 1/2	1	•	18.46	7.19	5.73	30.14	98	-	-	-	-	-
		3	•	18.46	5.55	4.57	27.08	71	-	-	-	-	-
CRN(E) 1-13	1 1/2	1	•	19.17	7.19	5.73	30.85	99	5.55	5.51	28.15	80	-
		3	•	19.17	5.55	4.57	27.79	72	7.01	6.57	31.97	97	-
CRN(E) 1-15	2	1	•	20.59	7.19	5.73	33.15	108	-	-	-	-	-
		3	•	20.59	7.01	4.33	31.81	99	7.01	6.57	33.39	112	-
CRN(E) 1-17	2	1	•	22.01	7.19	5.73	34.57	110	-	-	-	-	-
		3	•	22.01	7.01	4.33	33.23	101	7.01	6.57	34.81	113	-
CRN 1-19	3	1	•	23.43	8.60	6.87	38.08	148	-	-	-	-	-
		3	•	23.43	7.01	4.33	36.66	116	-	-	-	-	-
CRN 1-21	3	1	•	25.94	8.60	6.87	40.59	150	-	-	-	-	-
		3	•	25.94	7.01	4.33	39.17	118	-	-	-	-	-
CRN(E) 1-23	3	1	•	27.36	8.60	6.87	42.01	152	-	-	-	-	-
		3	•	27.36	7.01	4.33	40.59	123	7.01	6.57	40.67	131	-
CRN 1-25	3	1	•	28.78	8.60	6.87	43.43	154	-	-	-	-	-
		3	•	28.78	7.01	4.33	42.01	124	-	-	-	-	-
CRN(E) 1-27	3	1	•	30.20	8.60	6.87	44.85	155	-	-	-	-	-
		3	•	30.20	7.01	4.33	43.43	126	7.01	6.57	43.51	135	-

All dimensions in inches unless otherwise noted.

\*PJE flanged pump B1 and B1+B2 dimension is one inch less than ANSI flanged pump and weight is approximately 9 lbs. less.

• Available

## CR(E), CRI(E), CRN(E) 3

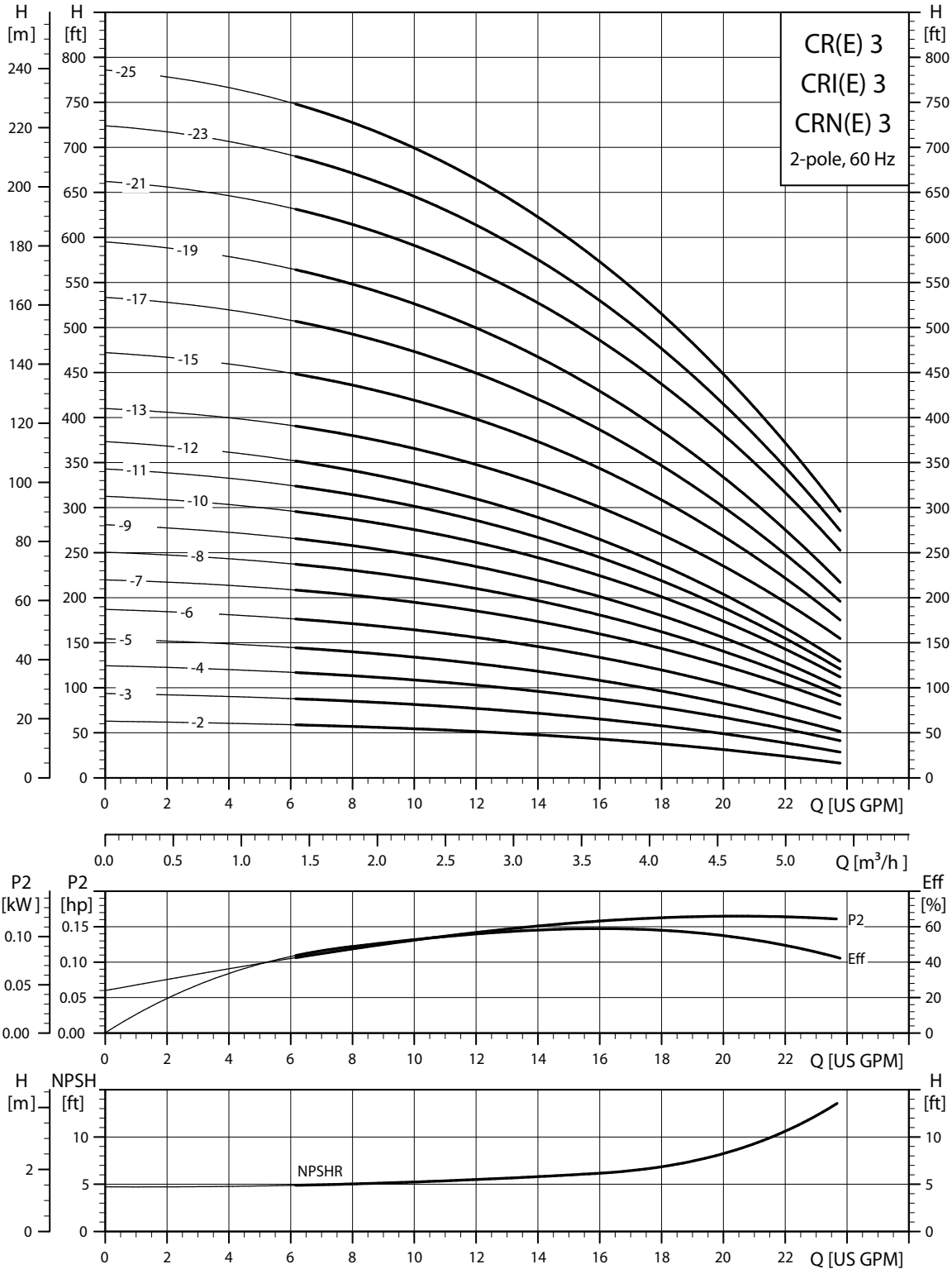

TM02 4084 1303

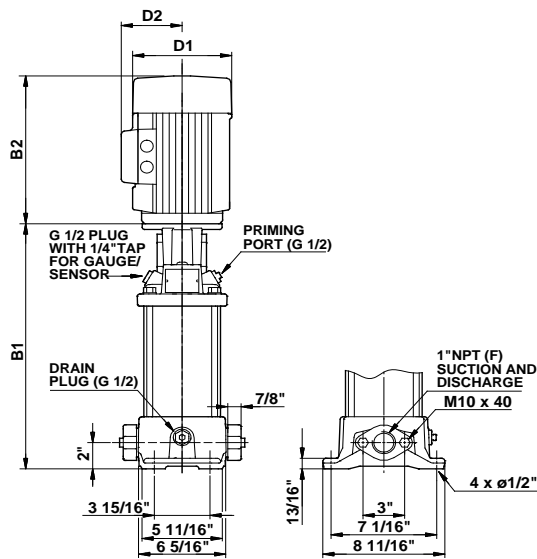

TM03 1450 2205

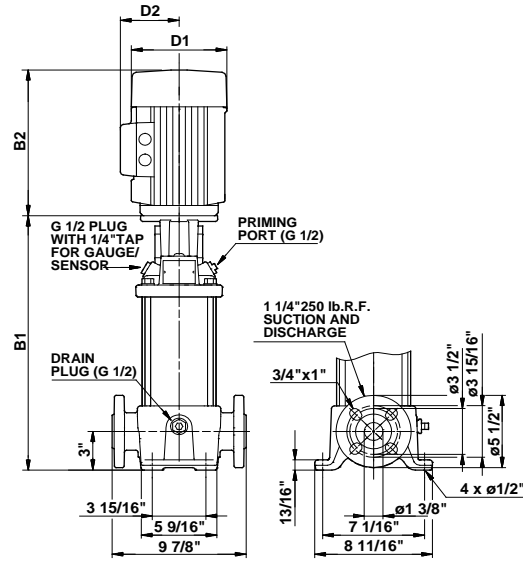

TM03 1451 2205

Pump type	P2 [hp]	Ph.	Oval*	ANSI dimensions [inch]					Ship Wt. [lbs.]	ANSI dimensions [inch]			
				B1	TEFC			Ship Wt. [lbs.]		MLE			
					D1	D2	B1+B2			D1	D2	B1+B2	
CR(E) 3-2	1/3	1	•	11.97	6.19	5.18	21.26	69	5.55	5.51	19.39	69	
		3	•	11.97	5.55	4.57	19.41	67	-	-	-	-	
CR 3-3	1/2	1	•	11.97	6.19	5.18	21.26	73	-	-	-	-	
		3	•	11.97	5.55	4.57	19.41	67	-	-	-	-	
CR(E) 3-4	3/4	1	•	12.68	6.19	5.18	22.59	78	5.55	5.51	20.10	72	
		3	•	12.68	5.55	4.57	20.12	69	-	-	-	-	
CR(E) 3-5	3/4	1	•	13.39	6.19	5.18	23.30	79	5.55	5.51	22.37	73	
		3	•	13.39	5.55	4.57	20.83	70	-	-	-	-	
CR(E) 3-6	1	1	•	14.09	7.19	5.73	25.28	91	-	-	-	-	
		3	•	14.09	5.55	4.57	21.53	71	7.01	6.57	26.89	90	
CR 3-7	1 1/2	1	•	14.80	7.19	5.73	26.48	95	-	-	-	-	
		3	•	14.80	5.55	4.57	23.42	72	-	-	-	-	
CR(E) 3-8	1 1/2	1	•	15.51	7.19	5.73	27.19	96	5.55	5.51	24.49	81	
		3	•	15.51	5.55	4.57	24.13	73	-	-	-	-	
CR(E) 3-9	1 1/2	1	•	16.22	7.19	5.73	27.90	97	-	-	-	-	
		3	•	16.22	5.55	4.57	24.84	74	7.01	6.57	29.02	99	
CR 3-10	2	1	•	16.93	7.19	5.73	29.49	109	-	-	-	-	
		3	•	16.93	7.01	4.33	28.15	96	-	-	-	-	
CR 3-11	2	1	•	17.64	7.19	5.73	30.20	110	-	-	-	-	
		3	•	17.64	7.01	4.33	28.86	101	-	-	-	-	
CR(E) 3-12	2	1	•	18.35	7.19	5.73	30.91	111	-	-	-	-	
		3	•	18.35	7.01	4.33	29.57	102	7.01	6.57	31.15	115	
CR 3-13	3	1	•	20.16	8.60	6.87	34.81	147	-	-	-	-	
		3	•	20.16	7.01	4.33	33.39	118	-	-	-	-	
CR(E) 3-15	3	1	•	21.57	8.60	6.87	36.22	149	-	-	-	-	
		3	•	21.57	7.01	4.33	34.80	120	7.01	6.57	34.88	128	
CR(E) 3-17	3	1	•	22.99	8.60	6.87	37.64	150	-	-	-	-	
		3	•	22.99	7.01	4.33	36.22	121	7.01	6.57	36.30	130	
CR 3-19	5	1	-	24.41	10.62	7.46	39.93	179	-	-	-	-	
		3	-	24.41	8.66	5.28	39.92	175	-	-	-	-	
CR 3-21	5	1	-	25.83	10.62	7.46	41.35	181	-	-	-	-	
		3	-	25.83	8.66	5.28	41.34	177	-	-	-	-	
CR 3-23	5	1	-	27.24	10.62	7.46	42.76	182	-	-	-	-	
		3	-	27.24	8.66	5.28	42.75	179	-	-	-	-	
CR(E) 3-25	5	1	-	28.66	10.62	7.46	44.18	184	-	-	-	-	
		3	-	28.66	8.66	5.28	44.17	181	8.66	7.40	44.17	172	

All dimensions in inches unless otherwise noted.

\*Oval flanged pump B1 and B1+B2 dimension is one inch less than ANSI flanged pump and weight is approximately 9 lbs. less.

• Available.

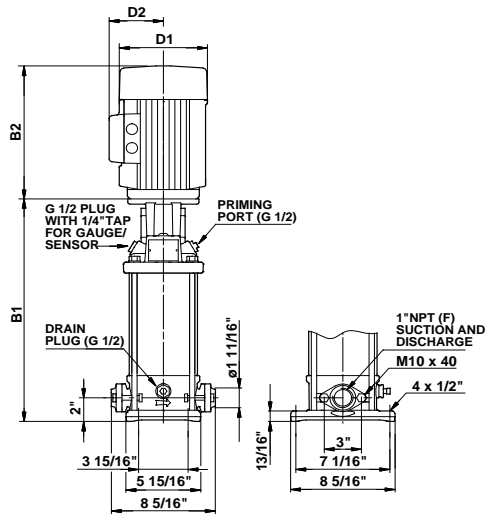

TM03 1452 2205

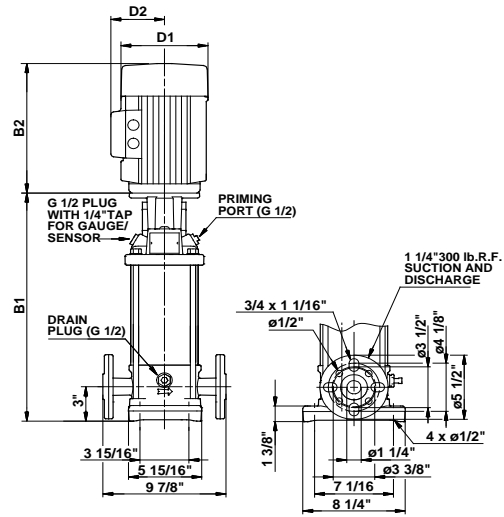

TM03 1453 2205

Pump type	P2 [hp]	Ph.	Oval*	ANSI dimensions [inch]				Ship Wt. [lbs.]	ANSI dimensions [inch]			
				B1	TEFC				MLE			Ship Wt. [lbs.]
					D1	D2	B1+B2		D1	D2	B1+B2	
CRI(E) 3-2	1/3	1	•	12.09	6.19	5.18	21.38	64	5.55	5.51	19.51	63
		3	•	12.09	5.55	4.57	19.53	62	-	-	-	-
CRI 3-3	1/2	1	•	12.09	6.19	5.18	21.38	67	-	-	-	-
		3	•	12.09	5.55	4.57	19.53	62	-	-	-	-
CRI(E) 3-4	3/4	1	•	12.80	6.19	5.18	22.71	73	5.55	5.51	20.22	67
		3	•	12.80	5.55	4.57	20.24	63	-	-	-	-
CRI(E) 3-5	3/4	1	•	13.50	6.19	5.18	23.41	74	5.55	5.51	22.48	68
		3	•	13.50	5.55	4.57	20.94	65	-	-	-	-
CRI(E) 3-6	1	1	•	14.21	7.19	5.73	25.40	86	-	-	-	-
		3	•	14.21	5.55	4.57	21.65	65	7.01	6.57	27.01	85
CRI 3-7	1 1/2	1	•	14.92	7.19	5.73	26.60	90	-	-	-	-
		3	•	14.92	5.55	4.57	23.54	67	-	-	-	-
CRI(E) 3-8	1 1/2	1	•	15.63	7.19	5.73	27.31	91	5.55	5.51	24.61	76
		3	•	15.63	5.55	4.57	24.25	68	-	-	-	-
CRI(E) 3-9	1 1/2	1	•	16.34	7.19	5.73	28.02	92	-	-	-	-
		3	•	16.34	5.55	4.57	24.96	69	7.01	6.57	29.14	93
CRI 3-10	2	1	•	17.05	7.19	5.73	29.61	104	-	-	-	-
		3	•	17.05	7.01	4.33	28.27	91	-	-	-	-
CRI 3-11	2	1	•	17.76	7.19	5.73	30.32	105	-	-	-	-
		3	•	17.76	7.01	4.33	28.98	95	-	-	-	-
CRI(E) 3-12	2	1	•	18.46	7.19	5.73	31.02	106	-	-	-	-
		3	•	18.46	7.01	4.33	29.68	96	7.01	6.57	31.26	109
CRI 3-13	3	1	•	20.28	8.60	6.87	34.93	140	-	-	-	-
		3	•	20.28	7.01	4.33	33.51	111	-	-	-	-
CRI(E) 3-15	3	1	•	21.69	8.60	6.87	36.34	142	-	-	-	-
		3	•	21.69	7.01	4.33	34.92	113	7.01	6.57	35.00	-
CRI(E) 3-17	3	1	•	23.11	8.60	6.87	37.76	143	-	-	-	-
		3	•	23.11	7.01	4.33	36.34	114	7.01	6.57	36.42	121
CRI 3-19	5	1	-	24.53	10.62	7.46	40.05	172	-	-	-	-
		3	-	24.53	8.66	5.28	40.04	168	-	-	-	-
CRI 3-21	5	1	-	25.94	10.62	7.46	41.46	174	-	-	-	-
		3	-	25.94	8.66	5.28	41.45	170	-	-	-	-
CRI 3-23	5	1	-	27.36	10.62	7.46	42.88	175	-	-	-	-
		3	-	27.36	8.66	5.28	42.87	172	-	-	-	-
CRI(E) 3-25	5	1	-	28.78	10.62	7.46	44.30	177	-	-	-	-
		3	-	28.78	8.66	5.28	44.29	174	8.66	7.40	44.29	165

All dimensions in inches unless otherwise noted.

\*Oval flanged pump B1 and B1+B2 dimension is one inch less than ANSI flanged pump and weight is approximately 9 lbs. less.

• Available.



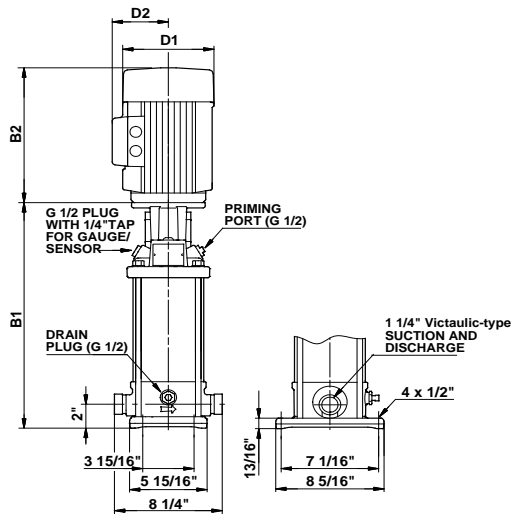

TM03 1454 2205

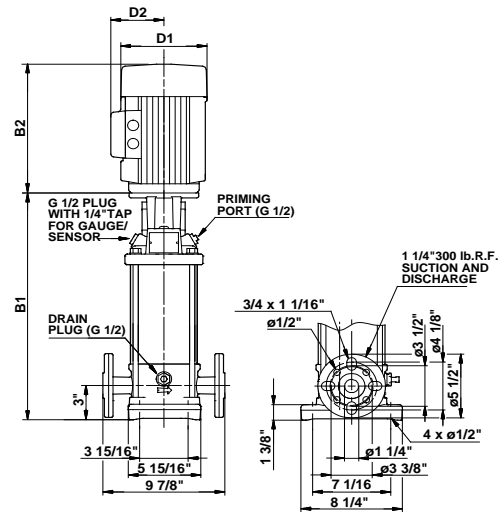

TM03 1453 2205

Pump type	P2 [hp]	Ph.	PJE*	ANSI dimensions [inch]				Ship Wt. [lbs.]
				B1	TEFC			
					D1	D2	B1+B2	
CRN(E) 3-2	1/3	1	●	12.09	6.19	5.18	21.38	64
				12.09	5.55	4.57	19.53	62
CRN 3-3	1/2	1	●	12.09	6.19	5.18	21.38	67
				12.09	5.55	4.57	19.53	62
CRN(E) 3-4	3/4	1	●	12.80	6.19	5.18	22.71	73
				12.80	5.55	4.57	20.24	63
CRN(E) 3-5	3/4	1	●	13.50	6.19	5.18	23.41	73
				13.50	5.55	4.57	20.94	64
CRN(E) 3-6	1	1	●	14.21	7.19	5.73	25.40	86
				14.21	5.55	4.57	21.65	65
CRN 3-7	1 1/2	1	●	14.92	7.19	5.73	26.60	90
				14.92	5.55	4.57	23.54	67
CRN(E) 3-8	1 1/2	1	●	15.63	7.19	5.73	27.31	91
				15.63	5.55	4.57	24.25	68
CRN(E) 3-9	1 1/2	1	●	16.34	7.19	5.73	28.02	92
				16.34	5.55	4.57	24.96	69
CRN 3-10	2	1	●	17.05	7.19	5.73	29.61	104
				17.05	7.01	4.33	28.27	91
CRN 3-11	2	1	●	17.76	7.19	5.73	30.32	105
				17.76	7.01	4.33	28.98	95
CRN(E) 3-12	2	1	●	18.46	7.19	5.73	31.02	106
				18.46	7.01	4.33	29.68	96
CRN 3-13	3	1	●	20.28	8.60	6.87	34.93	139
				20.28	7.01	4.33	33.51	110
CRN(E) 3-15	3	1	●	21.69	8.60	6.87	36.34	142
				21.69	7.01	4.33	34.92	112
CRN(E) 3-17	3	1	●	23.11	8.60	6.87	37.76	143
				23.11	7.01	4.33	36.34	114
CRN 3-19	5	1	●	24.53	10.62	7.46	40.05	172
				24.53	8.66	5.28	40.04	168
CRN 3-21	5	1	●	25.94	10.62	7.46	41.46	174
				25.94	8.66	5.28	41.45	170
CRN 3-23	5	1	●	27.36	10.62	7.46	42.88	175
				27.36	8.66	5.28	42.87	171
CRN(E) 3-25	5	1	●	28.78	10.62	7.46	44.30	177
				28.78	8.66	5.28	44.29	173

Pump type	ANSI dimensions [inch]			Ship Wt. [lbs.]
	MLE			
	D1	D2	B1+B2	
CRN(E) 3-2	5.55	5.51	19.51	63
	-	-	-	-
CRN 3-3	-	-	-	-
	-	-	-	-
CRN(E) 3-4	5.55	5.51	20.22	67
	-	-	-	-
CRN(E) 3-5	5.55	5.51	22.48	68
	-	-	-	-
CRN(E) 3-6	-	-	-	-
	7.01	6.57	27.01	85
CRN 3-7	-	-	-	-
	-	-	-	-
CRN(E) 3-8	5.55	5.51	24.61	76
	-	-	-	-
CRN(E) 3-9	-	-	-	-
	7.01	6.57	29.14	93
CRN 3-10	-	-	-	-
	-	-	-	-
CRN 3-11	-	-	-	-
	-	-	-	-
CRN(E) 3-12	-	-	-	-
	7.01	6.57	31.26	109
CRN 3-13	-	-	-	-
	-	-	-	-
CRN(E) 3-15	-	-	-	-
	7.01	6.57	35.00	-
CRN(E) 3-17	-	-	-	-
	7.01	6.57	36.42	121
CRN 3-19	-	-	-	-
	-	-	-	-
CRN 3-21	-	-	-	-
	-	-	-	-
CRN 3-23	-	-	-	-
	-	-	-	-
CRN(E) 3-25	-	-	-	-
	8.66	7.40	44.29	165

All dimensions in inches unless otherwise noted.

\*PJE flanged pump B1 and B1+B2 dimension is one inch less than ANSI flanged pump and weight is approximately 9 lbs. less.

● Available.

## CR(E), CRI(E), CRN(E) 5

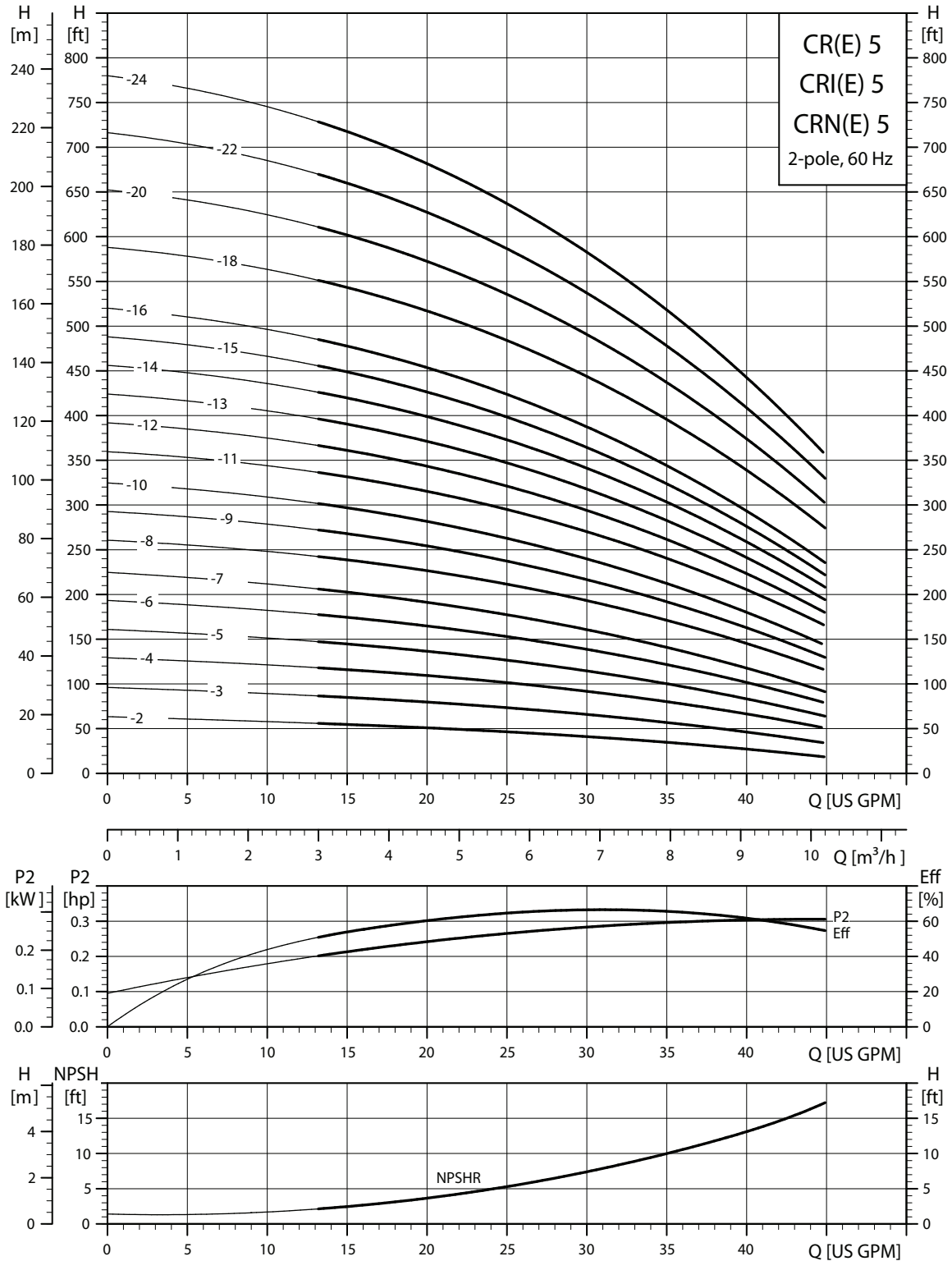

TM02 4085 1303

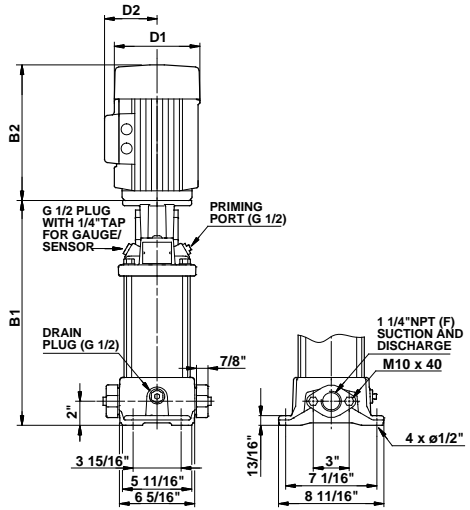

TM03 1455 2205

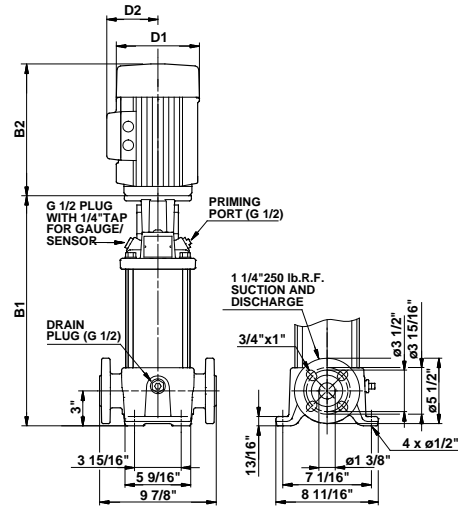

TM03 1451 2205

Pump type	P2 [hp]	Ph.	Oval*	ANSI dimensions [inch]				Ship Wt. [lbs.]	ANSI dimensions [inch]						
				B1	TEFC				D1	D2	B1+B2	MLE			Ship Wt. [lbs.]
					D1	D2	B1+B2					D1	D2	B1+B2	
CR(E) 5-2	3/4	1	•	11.97	6.19	5.18	21.88	77	5.55	5.51	19.39	71			
		3	•	11.97	5.55	4.57	19.41	68	-	-	-	-			
CR(E) 5-3	1	1	•	13.03	7.19	5.73	24.22	90	-	-	-	-			
		3	•	13.03	5.55	4.57	20.47	69	7.01	6.57	25.83	88			
CR(E) 5-4	1 1/2	1	•	14.09	7.19	5.73	25.77	94	5.55	5.51	23.07	79			
		3	•	14.09	5.55	4.57	22.71	71	7.01	6.57	26.89	92			
CR 5-5	2	1	•	15.16	7.19	5.73	27.72	106	-	-	-	-			
		3	•	15.16	7.01	4.33	26.38	93	-	-	-	-			
CR(E) 5-6	2	1	•	16.22	7.19	5.73	28.78	108	-	-	-	-			
		3	•	16.22	7.01	4.33	27.44	95	7.01	6.57	29.02	111			
CR 5-7	3	1	•	18.39	8.60	6.87	33.04	143	-	-	-	-			
		3	•	18.39	7.01	4.33	31.62	114	-	-	-	-			
CR 5-8	3	1	•	19.45	8.60	6.87	34.10	145	-	-	-	-			
		3	•	19.45	7.01	4.33	32.68	116	-	-	-	-			
CR(E) 5-9	3	1	•	20.51	8.60	6.87	35.16	147	-	-	-	-			
		3	•	20.51	7.01	4.33	33.74	118	7.01	6.57	33.82	126			
CR 5-10	5	1	•	21.57	10.62	7.46	37.09	170	-	-	-	-			
		3	•	21.57	8.66	5.28	37.08	168	-	-	-	-			
CR 5-11	5	1	•	22.64	10.62	7.46	38.16	172	-	-	-	-			
		3	•	22.64	8.66	5.28	38.15	169	-	-	-	-			
CR 5-12	5	1	•	23.70	10.62	7.46	39.22	177	-	-	-	-			
		3	•	23.70	8.66	5.28	39.21	170	-	-	-	-			
CR(E) 5-13	5	1	•	24.76	10.62	7.46	40.28	178	-	-	-	-			
		3	•	24.76	8.66	5.28	40.27	171	8.66	7.40	40.27	166			
CR 5-14	5	1	•	25.83	10.62	7.46	41.35	180	-	-	-	-			
		3	•	25.83	8.66	5.28	41.34	176	-	-	-	-			
CR(E) 5-15	5	1	•	26.89	10.62	7.46	42.41	181	-	-	-	-			
		3	•	26.89	8.66	5.28	42.40	177	8.66	7.40	42.40	169			
CR(E) 5-16	5	1	•	27.95	10.62	7.46	43.47	182	-	-	-	-			
		3	•	27.95	8.66	5.28	43.46	178	8.66	7.40	43.46	170			
CR 5-18	7 1/2	1	-	30.59	10.22	7.62	46.12	200	-	-	-	-			
		3	-	30.59	8.66	5.28	46.10	188	-	-	-	-			
CR(E) 5-20	7 1/2	1	-	32.72	10.22	7.62	48.25	203	-	-	-	-			
		3	-	32.72	8.66	5.28	48.23	190	8.66	7.40	48.23	204			
CR 5-22	7 1/2	1	-	34.84	10.22	7.62	50.37	300	-	-	-	-			
		3	-	34.84	8.66	5.28	50.35	287	-	-	-	-			
CR(E) 5-24	7 1/2	1	-	36.97	10.22	7.62	52.50	302	-	-	-	-			
		3	-	36.97	8.66	5.28	52.48	290	8.66	7.40	52.48	303			

All dimensions in inches unless otherwise noted.

\*Oval flanged pump B1 and B1+B2 dimension is one inch less than ANSI flanged pumps and weight is approximately 9 lbs. less.

• Available.

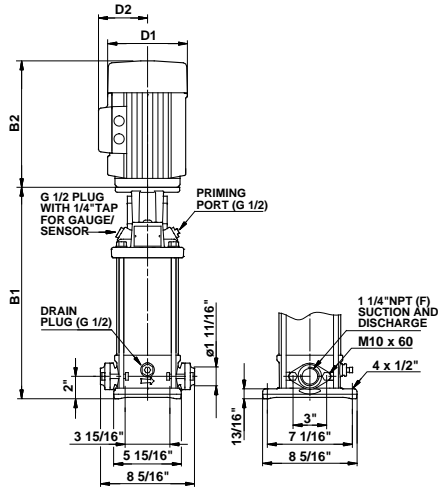

TM03 1456 2205

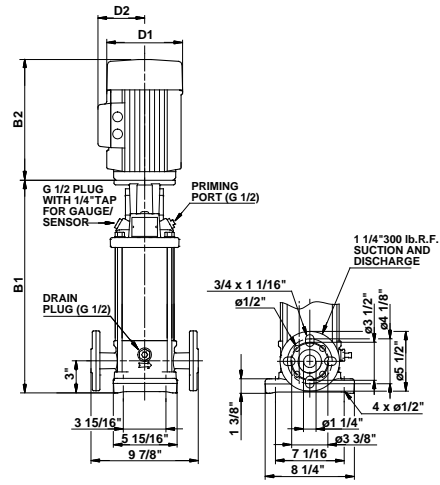

TM03 1453 2205

Pump type	P2 [hp]	Ph.	Oval*	ANSI dimensions [inch]				Ship Wt. [lbs.]	ANSI dimensions [inch]			
				B1	TEFC				MLE			Ship Wt. [lbs.]
					D1	D2	B1+B2		D1	D2	B1+B2	
CRI(E) 5-2	3/4	1	●	12.09	6.19	5.18	22.00	71	5.55	5.51	19.51	66
				12.09	5.55	4.57	19.53	62	-	-	-	-
CRI(E) 5-3	1	1	●	13.15	7.19	5.73	24.34	85	-	-	-	-
				13.15	5.55	4.57	20.59	64	7.01	6.57	25.95	83
CRI(E) 5-4	1 1/2	1	●	14.21	7.19	5.73	25.89	89	5.55	5.51	23.19	74
				14.21	5.55	4.57	22.83	66	7.01	6.57	27.01	87
CRI 5-5	2	1	●	15.28	7.19	5.73	27.84	101	-	-	-	-
				15.28	7.01	4.33	26.50	88	-	-	-	-
CRI(E) 5-6	2	1	●	16.34	7.19	5.73	28.90	103	-	-	-	-
				16.34	7.01	4.33	27.56	90	7.01	6.57	29.14	106
CRI 5-7	3	1	●	18.51	8.60	6.87	33.16	136	-	-	-	-
				18.51	7.01	4.33	31.74	107	-	-	-	-
CRI 5-8	3	1	●	19.57	8.60	6.87	34.22	138	-	-	-	-
				19.57	7.01	4.33	32.80	109	-	-	-	-
CRI(E) 5-9	3	1	●	20.63	8.60	6.87	35.28	140	-	-	-	-
				20.63	7.01	4.33	33.86	111	7.01	6.57	33.94	120
CRI 5-10	5	1	●	21.69	10.62	7.46	37.21	163	-	-	-	-
				21.69	8.66	5.28	37.20	160	-	-	-	-
CRI 5-11	5	1	●	22.76	10.62	7.46	38.28	165	-	-	-	-
				22.76	8.66	5.28	38.27	162	-	-	-	-
CRI 5-12	5	1	●	23.82	10.62	7.46	39.34	170	-	-	-	-
				23.82	8.66	5.28	39.33	163	-	-	-	-
CRI(E) 5-13	5	1	●	24.88	10.62	7.46	40.40	171	-	-	-	-
				24.88	8.66	5.28	40.39	164	8.66	7.40	40.39	159
CRI 5-14	5	1	●	25.94	10.62	7.46	41.46	173	-	-	-	-
				25.94	8.66	5.28	41.45	169	-	-	-	-
CRI(E) 5-15	5	1	●	27.01	10.62	7.46	42.53	174	-	-	-	-
				27.01	8.66	5.28	42.52	170	8.66	7.40	42.52	161
CRI(E) 5-16	5	1	●	28.07	10.62	7.46	43.59	175	-	-	-	-
				28.07	8.66	5.28	43.58	171	8.66	7.40	43.58	163
CRI 5-18	7 1/2	1	-	30.71	10.22	7.62	46.24	193	-	-	-	-
				30.71	8.66	5.28	46.22	181	-	-	-	-
CRI(E) 5-20	7 1/2	1	-	32.83	10.22	7.62	48.36	196	-	-	-	-
				32.83	8.66	5.28	48.34	183	8.66	7.40	48.34	196
CRI 5-22	7 1/2	1	-	34.96	10.22	7.62	50.49	293	-	-	-	-
				34.96	8.66	5.28	50.47	280	-	-	-	-
CRI(E) 5-24	7 1/2	1	-	37.09	10.22	7.62	52.62	295	-	-	-	-
				37.09	8.66	5.28	52.60	283	8.66	7.40	52.60	295

All dimensions in inches unless otherwise noted.

\*Oval flanged pump B1 and B1+B2 dimension is one inch less than ANSI flanged pumps and weight is approximately 9 lbs. less.

● Available.

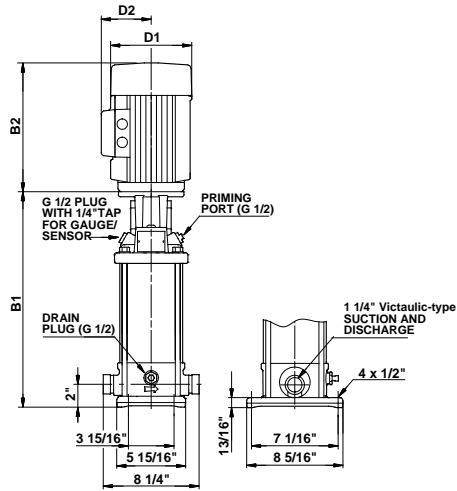

TM03 1454 2205

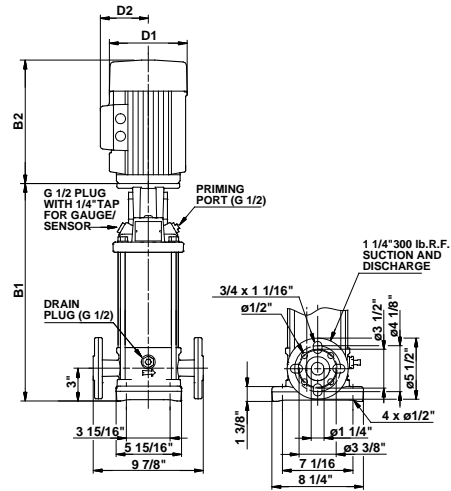

TM03 1453 2205

Pump type	P2 [hp]	Ph.	PJE*	ANSI dimensions [inch]				Ship Wt. [lbs.]	ANSI dimensions [inch]			Ship Wt. [lbs.]
				B1	TEFC				MLE			
					D1	D2	B1+B2		D1	D2	B1+B2	
CRN(E) 5-2	3/4	1	•	12.09	6.19	5.18	22.00	71	5.55	5.51	19.51	66
		3	•	12.09	5.55	4.57	19.53	62	-	-	-	-
CRN(E) 5-3	1	1	•	13.15	7.19	5.73	24.34	85	-	-	-	-
		3	•	13.15	5.55	4.57	20.59	64	7.01	6.57	25.95	83
CRN(E) 5-4	1 1/2	1	•	14.21	7.19	5.73	25.89	89	5.55	5.51	23.19	74
		3	•	14.21	5.55	4.57	22.83	65	7.01	6.57	27.01	87
CRN 5-5	2	1	•	15.28	7.19	5.73	27.84	101	-	-	-	-
		3	•	15.28	7.01	4.33	26.50	88	-	-	-	-
CRN(E) 5-6	2	1	•	16.34	7.19	5.73	28.90	103	-	-	-	-
		3	•	16.34	7.01	4.33	27.56	90	7.01	6.57	29.14	106
CRN 5-7	3	1	•	18.51	8.60	6.87	33.16	136	-	-	-	-
		3	•	18.51	7.01	4.33	31.74	107	-	-	-	-
CRN 5-8	3	1	•	19.57	8.60	6.87	34.22	138	-	-	-	-
		3	•	19.57	7.01	4.33	32.80	109	-	-	-	-
CRN(E) 5-9	3	1	•	20.63	8.60	6.87	35.28	139	-	-	-	-
		3	•	20.63	7.01	4.33	33.86	110	7.01	6.57	33.94	120
CRN 5-10	5	1	•	21.69	10.62	7.46	37.21	163	-	-	-	-
		3	•	21.69	8.66	5.28	37.20	160	-	-	-	-
CRN 5-11	5	1	•	22.76	10.62	7.46	38.28	165	-	-	-	-
		3	•	22.76	8.66	5.28	38.27	161	-	-	-	-
CRN 5-12	5	1	•	23.82	10.62	7.46	39.34	170	-	-	-	-
		3	•	23.82	8.66	5.28	39.33	163	-	-	-	-
CRN(E) 5-13	5	1	•	24.88	10.62	7.46	40.40	171	-	-	-	-
		3	•	24.88	8.66	5.28	40.39	164	8.66	7.40	40.39	159
CRN 5-14	5	1	•	25.94	10.62	7.46	41.46	172	-	-	-	-
		3	•	25.94	8.66	5.28	41.45	169	-	-	-	-
CRN(E) 5-15	5	1	•	27.01	10.62	7.46	42.53	173	-	-	-	-
		3	•	27.01	8.66	5.28	42.52	170	8.66	7.40	42.52	161
CRN(E) 5-16	5	1	•	28.07	10.62	7.46	43.59	175	-	-	-	-
		3	•	28.07	8.66	5.28	43.58	171	8.66	7.40	43.58	163
CRN 5-18	7 1/2	1	•	30.71	10.22	7.62	46.24	193	-	-	-	-
		3	•	30.71	8.66	5.28	46.22	180	-	-	-	-
CRN(E) 5-20	7 1/2	1	•	32.83	10.22	7.62	48.36	196	-	-	-	-
		3	•	32.83	8.66	5.28	48.34	183	8.66	7.40	48.34	196
CRN 5-22	7 1/2	1	•	34.96	10.22	7.62	50.49	292	-	-	-	-
		3	•	34.96	8.66	5.28	50.47	279	-	-	-	-
CRN(E) 5-24	7 1/2	1	•	37.09	10.22	7.62	52.62	295	-	-	-	-
		3	•	37.09	8.66	5.28	52.60	282	8.66	7.40	52.60	295

All dimensions in inches unless otherwise noted. • Available.

\*PJE flanged pump B1 and B1+B2 dimension is one inch less than ANSI flanged pumps and weight is approximately 9 lbs. less.

## CR(E), CRI(E), CRN(E) 10

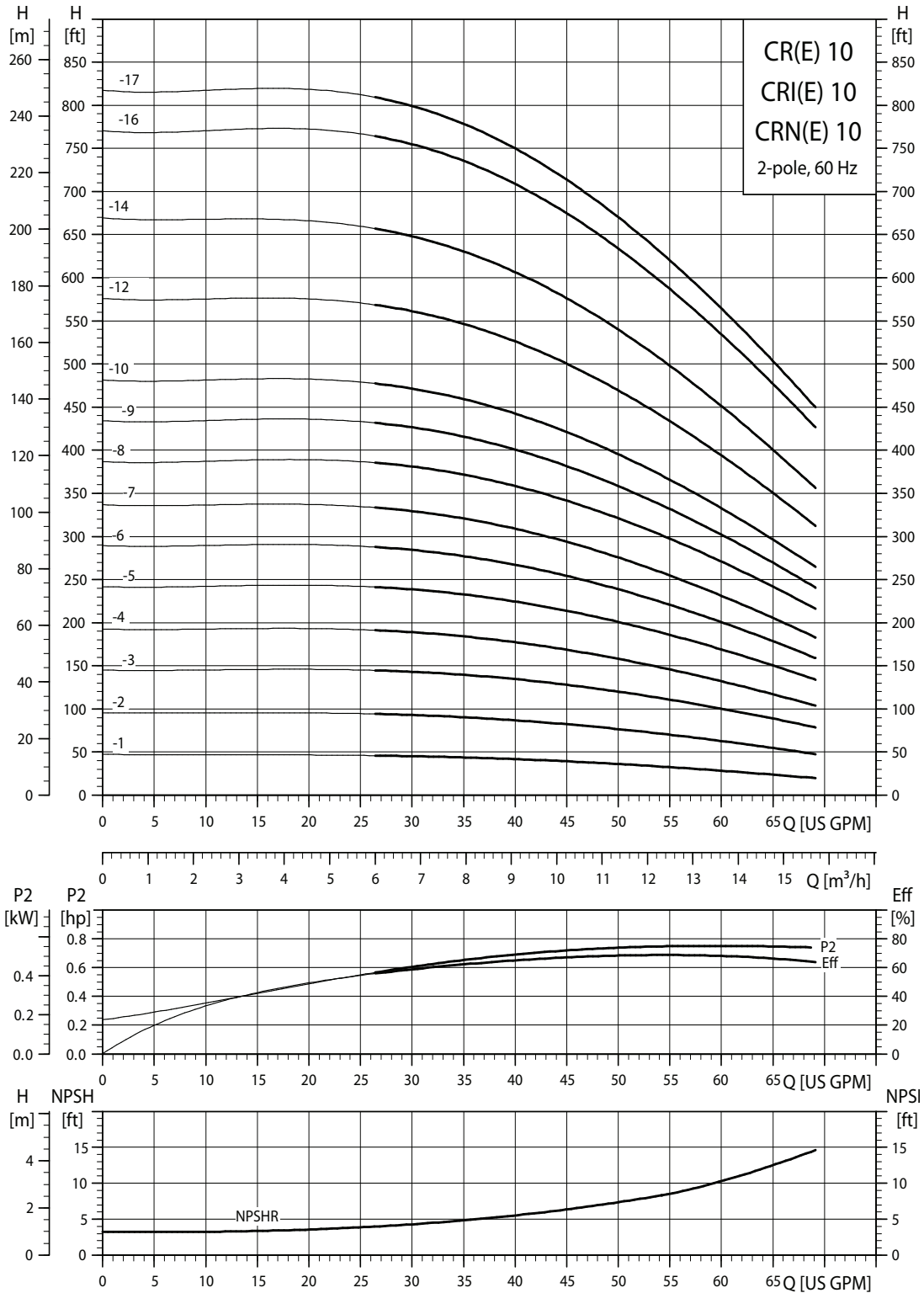

TM02 7221 3704

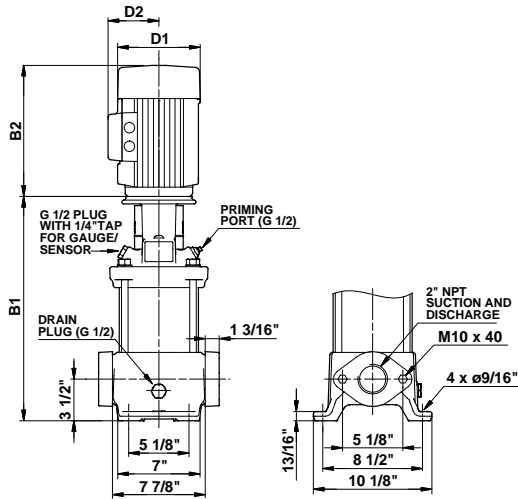

TM03 1460 2205

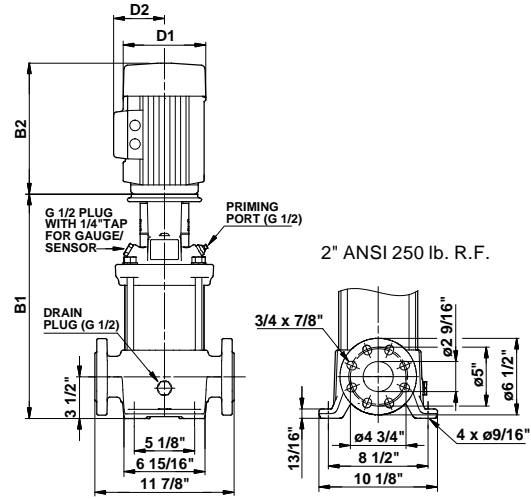

TM03 1461 2205

Pump type	P2 [hp]	Ph.	Oval*	ANSI dimensions [inch]							Ship Wt. [lbs.]	ANSI dimensions [inch]			
				B1	TEFC			ODP				MLE			Ship Wt. [lbs.]
					D1	D2	B1+B2	D1	D2	B1+B2		D1	D2	B1+B2	
CR(E) 10-1	3/4	1	•	15.28	7.19	5.73	26.47	-	-	-	115	5.55	5.51	24.26	108
		3	•	15.28	5.55	4.57	22.72	-	-	-	106	7.01	6.57	28.08	128
CR(E) 10-2	1 1/2	1	•	15.28	7.19	5.73	26.96	-	-	-	128	-	-	-	-
		3	•	15.28	5.55	4.57	23.90	-	-	-	106	7.01	6.57	28.08	128
CR 10-3	3	1	•	17.20	8.60	6.87	31.85	-	-	-	183	-	-	-	-
		3	•	17.20	7.01	4.33	30.43	-	-	-	153	-	-	-	-
CR(E) 10-4	3	1	•	18.39	8.60	6.87	33.04	-	-	-	183	-	-	-	-
		3	•	18.39	7.01	4.33	31.62	-	-	-	156	7.01	6.57	31.70	163
CR 10-5	5	1	•	19.57	10.62	7.46	35.09	-	-	-	209	-	-	-	-
		3	•	19.57	8.66	5.28	35.08	-	-	-	206	-	-	-	-
CR(E) 10-6	5	1	•	20.75	10.62	7.46	36.27	-	-	-	212	-	-	-	-
		3	•	20.75	8.66	5.28	36.26	-	-	-	208	8.66	7.40	36.26	201
CR 10-7	7 1/2	1	-	22.25	10.22	7.62	37.78	-	-	-	232	-	-	-	-
		3	-	22.25	8.66	5.28	37.76	-	-	-	221	-	-	-	-
CR(E) 10-8	7 1/2	1	-	23.43	10.22	7.62	38.96	-	-	-	234	-	-	-	-
		3	-	23.43	8.66	5.28	38.94	-	-	-	223	8.66	7.40	38.94	236
CR 10-9	7 1/2	1	-	24.61	10.22	7.62	40.14	-	-	-	236	-	-	-	-
		3	-	24.61	8.66	5.28	40.12	-	-	-	225	-	-	-	-
CR(E) 10-10	7 1/2	1	-	25.79	10.22	7.62	41.32	-	-	-	238	-	-	-	-
		3	-	25.79	8.66	5.28	41.30	-	-	-	227	8.66	7.40	41.30	240
CR(E) 10-12	10	1	-	28.15	10.23	10.30	44.22	-	-	-	355	-	-	-	-
		3	-	28.15	8.66	5.28	43.66	-	-	-	232	10.24	8.39	43.07	251
CR(E) 10-14	15	3	-	33.06	10.22	8.67	49.64	10.62	7.33	49.37	443	13.39	12.13	51.84	504
CR 10-16	15	3	-	35.43	10.22	8.67	52.01	10.62	7.33	51.74	451	-	-	-	-
CR(E) 10-17	15	3	-	37.80	10.22	8.67	54.38	10.62	7.33	54.11	455	13.39	12.13	56.58	519

All dimensions in inches unless otherwise noted.

\*Oval flanged pump B1 and B1+B2 dimension is equal to ANSI flanged pumps and weight is approximately 3 lbs. less.

• Available.

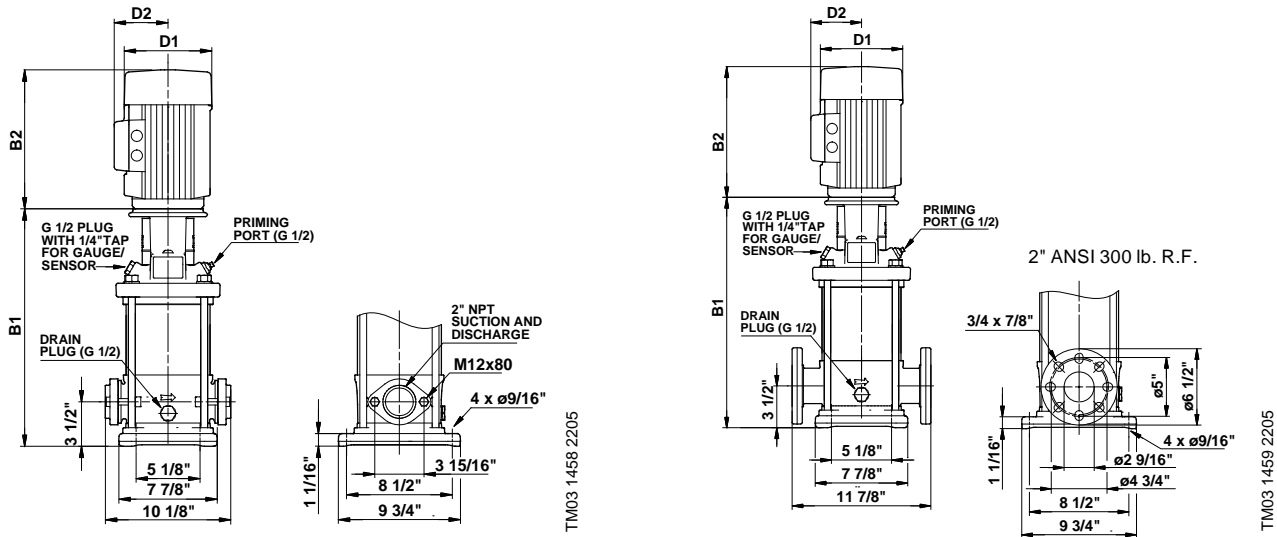

Pump type	P2 [hp]	Ph.	Oval*	ANSI dimensions [inch]						Ship Wt. [lbs.]	ANSI dimensions [inch]			Ship Wt. [lbs.]	
				B1	TEFC			ODP			MLE				
					D1	D2	B1+B2	D1	D2		B1+B2	D1	D2		B1+B2
CRI(E) 10-1	1	1 3	● ●	15.20	7.19	5.73	26.39	-	-	-	106	5.55	5.51	24.18	97
				15.20	5.55	4.57	22.64	-	-	-	97	7.01	6.57	28.00	119
CRI(E) 10-2	1 1/2	1 3	● ●	15.20	7.19	5.73	26.88	-	-	-	121	-	-	-	-
				15.20	5.55	4.57	23.82	-	-	-	99	7.01	6.57	28.00	119
CRI 10-3	3	1 3	● ●	17.13	8.60	6.87	31.78	-	-	-	174	-	-	-	-
				17.13	7.01	4.33	30.36	-	-	-	147	-	-	-	-
CRI(E) 10-4	3	1 3	● ●	18.31	8.60	6.87	32.96	-	-	-	176	-	-	-	-
				18.31	7.01	4.33	31.54	-	-	-	147	7.01	6.57	31.62	157
CRI 10-5	5	1 3	● ●	19.49	10.62	7.46	35.01	-	-	-	203	-	-	-	-
				19.49	8.66	5.28	35.00	-	-	-	199	-	-	-	-
CRI(E) 10-6	5	1 3	● ●	20.67	10.62	7.46	36.19	-	-	-	205	-	-	-	-
				20.67	8.66	5.28	36.18	-	-	-	201	8.66	7.40	36.18	194
CRI 10-7	7 1/2	1 3	● ●	22.17	10.22	7.62	37.70	-	-	-	225	-	-	-	-
				22.17	8.66	5.28	37.68	-	-	-	212	-	-	-	-
CRI(E) 10-8	7 1/2	1 3	● ●	23.35	10.22	7.62	38.88	-	-	-	227	-	-	-	-
				23.35	8.66	5.28	38.86	-	-	-	214	8.66	7.40	38.86	229
CRI 10-9	7 1/2	1 3	● ●	24.53	10.22	7.62	40.06	-	-	-	229	-	-	-	-
				24.53	8.66	5.28	40.04	-	-	-	216	-	-	-	-
CRI(E) 10-10	7 1/2	1 3	● ●	25.71	10.22	7.62	41.24	-	-	-	232	-	-	-	-
				25.71	8.66	5.28	41.22	-	-	-	218	8.66	7.40	41.22	234
CRI(E) 10-12	10	1 3	- -	28.07	10.23	10.30	44.14	-	-	-	346	-	-	-	-
				28.07	8.66	5.28	43.58	-	-	-	225	10.24	8.39	42.99	243
CRI(E) 10-14	15	3	-	32.95	10.22	8.67	49.53	10.62	7.33	49.26	432	13.39	12.13	51.73	497
CRI 10-16	15	3	-	35.31	10.22	8.67	51.89	10.62	7.33	51.62	442	-	-	-	-
CRI(E) 10-17	15	3	-	37.68	10.22	8.67	54.26	10.62	7.33	53.99	447	13.39	12.13	56.46	513

All dimensions in inches unless otherwise noted.

\*Oval flanged pump B1 and B1+B2 dimension is equal to ANSI flanged pumps and weight is approximately 7 lbs. less.

● Available.



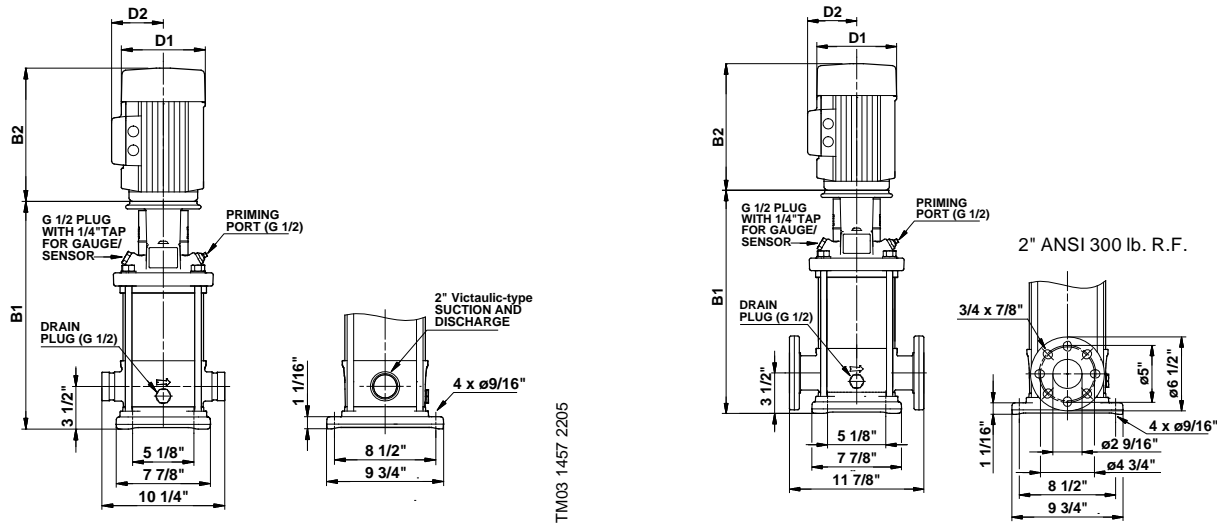

Pump type	P2 [hp]	Ph.	PJE*	ANSI dimensions [inch]							Ship Wt. [lbs.]	ANSI dimensions [inch]				Ship Wt. [lbs.]
				B1	TEFC			ODP				MLE				
					D1	D2	B1+B2	D1	D2	B1+B2		D1	D2	B1+B2		
CRN(E) 10-1	1	1	●	15.20	7.19	5.73	26.39	-	-	-	106	5.55	5.51	24.18	97	
				3	●	15.20	5.55	4.57	22.64	-	-	-	97	7.01	6.57	28.00
CRN(E) 10-2	1 1/2	1	●	15.20	7.19	5.73	26.88	-	-	-	121	-	-	-	-	
				3	●	15.20	5.55	4.57	23.82	-	-	-	99	7.01	6.57	28.00
CRN 10-3	3	1	●	17.13	8.60	6.87	31.78	-	-	-	176	-	-	-	-	
				3	●	17.13	7.01	4.33	30.36	-	-	-	147	-	-	-
CRN(E) 10-4	3	1	●	18.31	8.60	6.87	32.96	-	-	-	176	-	-	-	-	
				3	●	18.31	7.01	4.33	31.54	-	-	-	149	7.01	6.57	31.62
CRN 10-5	5	1	●	19.49	10.62	7.46	35.01	-	-	-	203	-	-	-	-	
				3	●	19.49	8.66	5.28	35.00	-	-	-	199	-	-	-
CRN(E) 10-6	5	1	●	20.67	10.62	7.46	36.19	-	-	-	205	-	-	-	-	
				3	●	20.67	8.66	5.28	36.18	-	-	-	201	8.66	7.40	36.18
CRN 10-7	7 1/2	1	●	22.17	10.22	7.62	37.70	-	-	-	227	-	-	-	-	
				3	●	22.17	8.66	5.28	37.68	-	-	-	214	-	-	-
CRN(E) 10-8	7 1/2	1	●	23.35	10.22	7.62	38.88	-	-	-	229	-	-	-	-	
				3	●	23.35	8.66	5.28	38.86	-	-	-	216	8.66	7.40	38.86
CRN 10-9	7 1/2	1	●	24.53	10.22	7.62	40.06	-	-	-	232	-	-	-	-	
				3	●	24.53	8.66	5.28	40.04	-	-	-	218	-	-	-
CRN(E) 10-10	7 1/2	1	●	25.71	10.22	7.62	41.24	-	-	-	234	-	-	-	-	
				3	●	25.71	8.66	5.28	41.22	-	-	-	221	8.66	7.40	41.22
CRN(E) 10-12	10	1	●	28.07	10.23	10.30	44.14	-	-	-	346	-	-	-	-	
				3	●	28.07	8.66	5.28	43.58	-	-	-	225	10.24	8.39	42.99
CRN(E) 10-14	15	3	●	32.95	10.22	8.67	49.53	10.62	7.33	49.25	432	13.39	12.13	51.73	497	
CRN 10-16	15	3	●	35.31	10.22	8.67	51.89	10.62	7.33	51.63	442	-	-	-	-	
CRN(E) 10-17	15	3	●	37.68	10.22	8.67	54.26	10.62	7.33	54.00	447	13.39	12.13	56.46	513	

All dimensions in inches unless otherwise noted.

\*PJE flanged pump B1 and B1+B2 dimension is equal to ANSI flanged pumps and weight is approximately 9 lbs. less.

● Available

## CR(E), CRI(E), CRN(E) 15

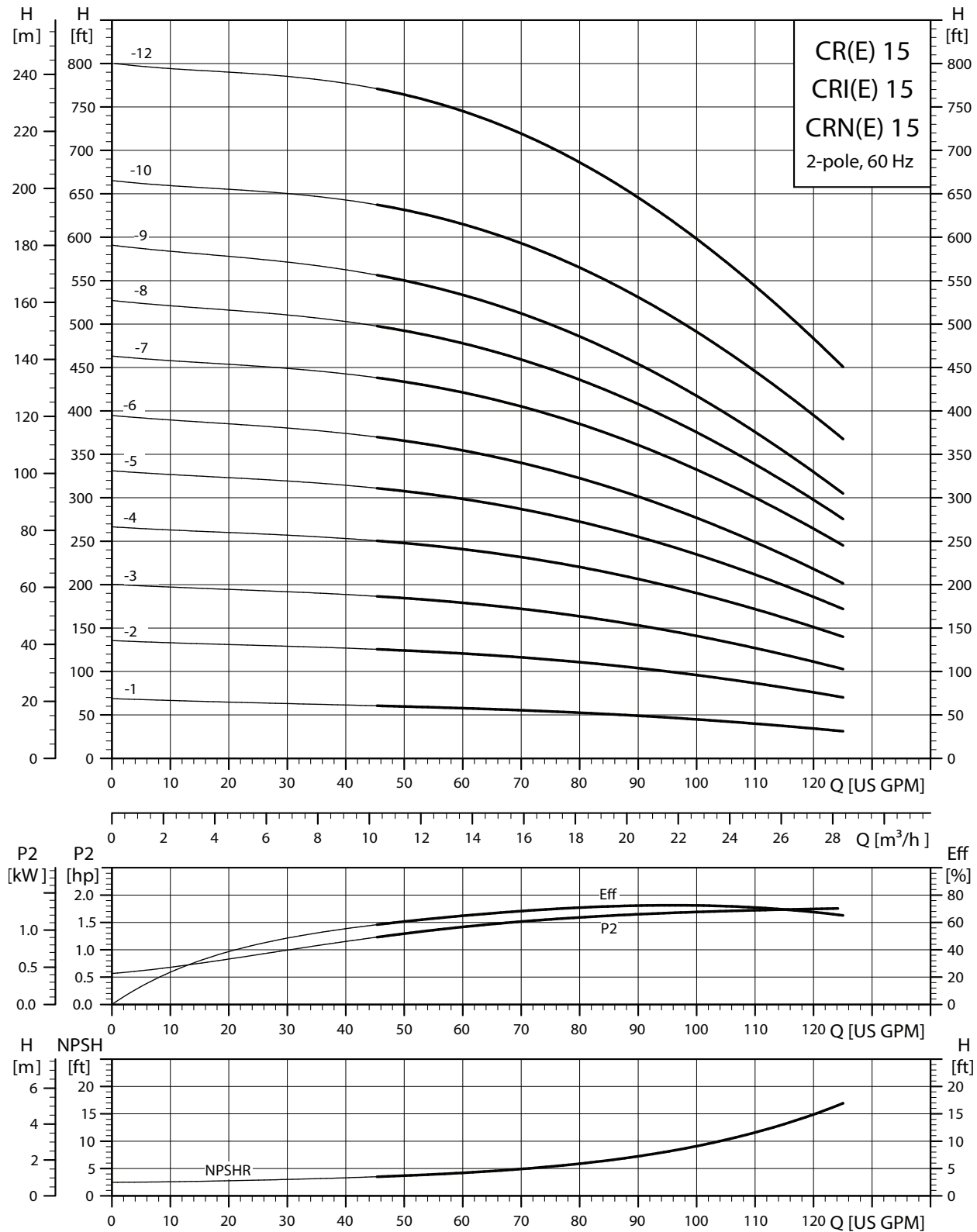

TM02 7222 2803

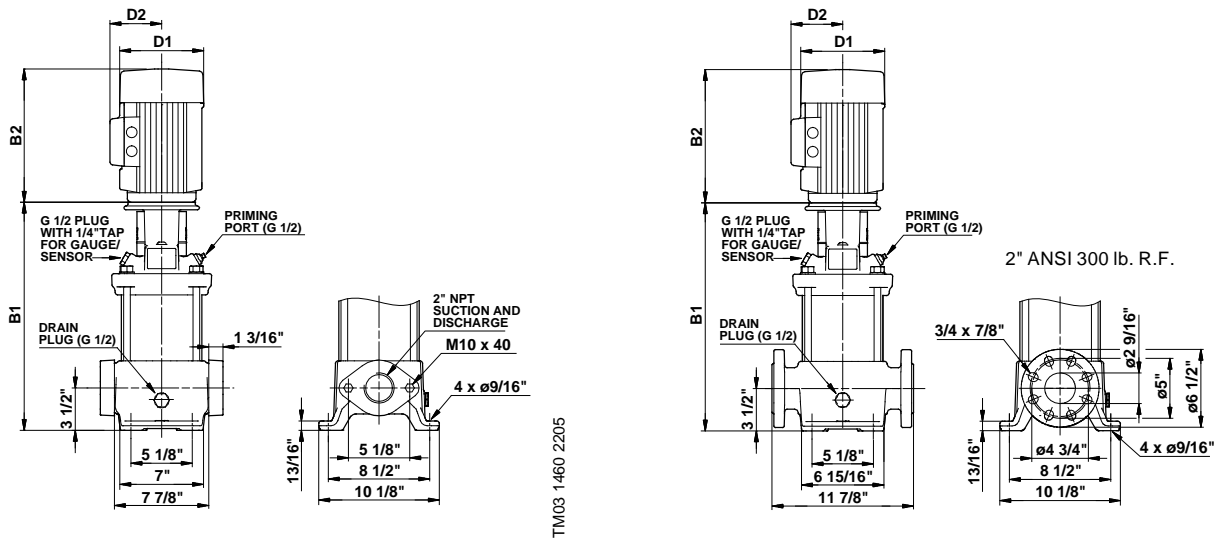

Pump type	P2 [hp]	Ph.	Oval*	ANSI dimensions [inch]									Ship Wt. [lbs.]		
				B1	TEFC			ODP			ANSI dimensions [inch]			Ship Wt. [lbs.]	
					D1	D2	B1+B2	D1	D2	B1+B2	D1	D2			B1+B2
CR(E) 15-1	2	1	•	16.46	7.19	5.73	29.02	-	-	-	139	-	-	-	-
		3	•	16.46	7.01	4.33	27.68	-	-	-	128	7.01	6.57	29.26	141
CR(E) 15-2	5	1	•	17.20	10.62	7.46	32.72	-	-	-	205	-	-	-	-
		3	•	17.20	8.66	5.28	32.71	-	-	-	201	8.66	7.40	30.00	194
CR(E) 15-3	7 1/2	1	•	19.29	10.22	7.62	34.82	-	-	-	223	-	-	-	-
		3	•	19.29	8.66	5.28	34.80	-	-	-	212	8.66	7.40	19.29	206
CR(E) 15-4	7 1/2	1	•	21.06	10.22	7.62	36.59	-	-	-	225	-	-	-	-
		3	•	21.06	8.66	5.28	36.57	-	-	-	214	8.66	7.40	34.37	227
CR(E) 15-5	10	1	•	22.83	10.23	10.30	38.90	-	-	-	342	-	-	-	-
		3	•	22.83	8.66	5.28	38.34	-	-	-	218	10.24	8.39	22.83	238
CR(E) 15-6	15	3	-	27.17	10.22	8.67	43.75	10.62	7.33	43.48	376	13.39	12.13	45.95	402
CR 15-7	15	3	-	28.94	10.22	8.67	45.52	10.62	7.33	45.25	407	-	-	-	-
CR(E) 15-8	15	3	-	30.71	10.22	8.67	47.29	10.62	7.33	47.02	438	13.39	12.13	49.49	504
CR 15-9	20	3	-	32.48	10.22	8.67	49.06	11.50	8.92	52.17	446	-	-	-	-
CR(E) 15-10	20	3	-	34.25	10.22	8.67	50.83	11.50	8.92	53.94	450	13.39	12.13	53.03	517
CR(E) 15-12	25	3	-	37.17	12.94	11.52	56.99	11.50	8.94	57.98	505	13.39	12.13	59.89	552

All dimensions in inches unless otherwise noted.

\*Oval flanged pump B1 and B1+B2 dimension is equal to ANSI flanged pumps and weight is approximately 3 lbs. less.

• Available.

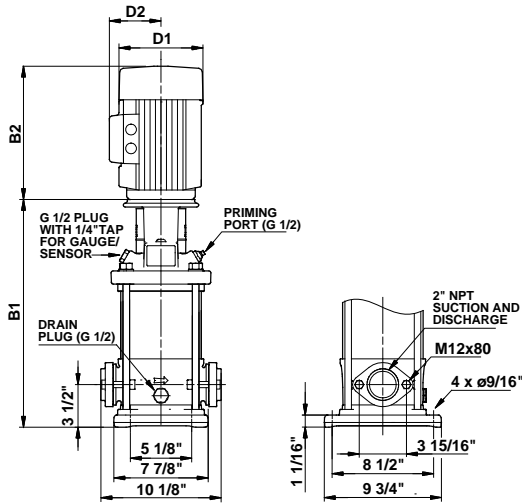

TM03 1458 2205

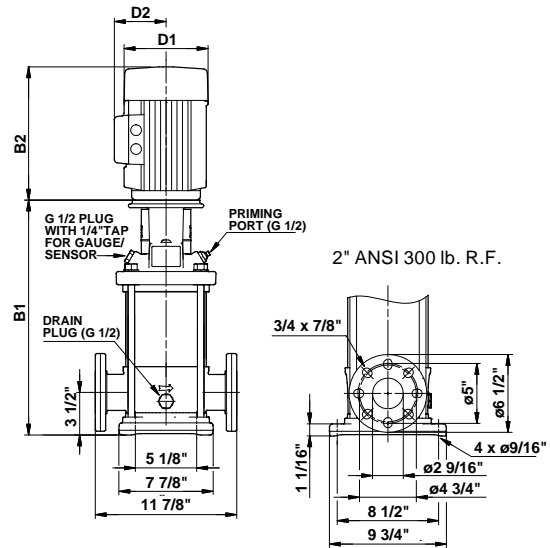

TM03 1459 2205

Pump type	P2 [hp]	Ph.	Oval*	ANSI dimensions [inch]						Ship Wt. [lbs.]	ANSI dimensions [inch]			Ship Wt. [lbs.]	
				B1	TEFC			ODP			MLE				
					D1	D2	B1+B2	D1	D2		B1+B2	D1	D2		B1+B2
CRI(E) 15-1	2	1	●	16.38	7.19	5.73	28.94	-	-	-	130	-	-	-	-
				16.38	7.01	4.33	27.60	-	-	-	7.01	6.57	29.18	135	
CRI(E) 15-2	5	1	●	17.13	10.62	7.46	32.65	-	-	-	198	-	-	-	-
				17.13	8.66	5.28	32.64	-	-	-	8.66	7.40	29.93	185	
CRI(E) 15-3	7 1/2	1	●	19.21	10.22	7.62	34.74	-	-	-	216	-	-	-	-
				19.21	8.66	5.28	34.72	-	-	-	8.66	7.40	19.21	200	
CRI(E) 15-4	7 1/2	1	●	20.98	10.22	7.62	36.51	-	-	-	218	-	-	-	-
				20.98	8.66	5.28	36.49	-	-	-	8.66	7.40	34.29	218	
CRI(E) 15-5	10	1	●	22.76	10.23	10.30	38.83	-	-	-	333	-	-	-	-
				22.76	8.66	5.28	38.27	-	-	-	10.24	8.39	22.76	229	
CRI(E) 15-6	15	3	●	27.05	10.22	8.67	43.63	10.62	7.33	43.36	365	13.39	12.13	45.83	477
CRI 15-7	15	3	●	28.82	10.22	8.67	45.40	10.62	7.33	45.13	398	-	-	-	-
CRI(E) 15-8	15	3	●	30.59	10.22	8.67	47.17	10.62	7.33	46.90	431	13.39	12.13	49.37	495
CRI 15-9	20	3	-	32.36	10.22	8.67	48.94	11.50	8.92	52.05	439	-	-	-	-
CRI(E) 15-10	20	3	-	34.13	10.22	8.67	50.71	11.50	8.92	53.82	442	13.39	12.13	52.91	510
CRI(E) 15-12	25	3	-	37.05	12.94	11.52	56.87	11.50	8.94	57.86	496	13.39	12.13	59.77	543

All dimensions in inches unless otherwise noted.

\*Oval flanged pump B1 and B1+B2 dimension is equal to ANSI flanged pumps and weight is approximately 7 lbs. less.

● Available.

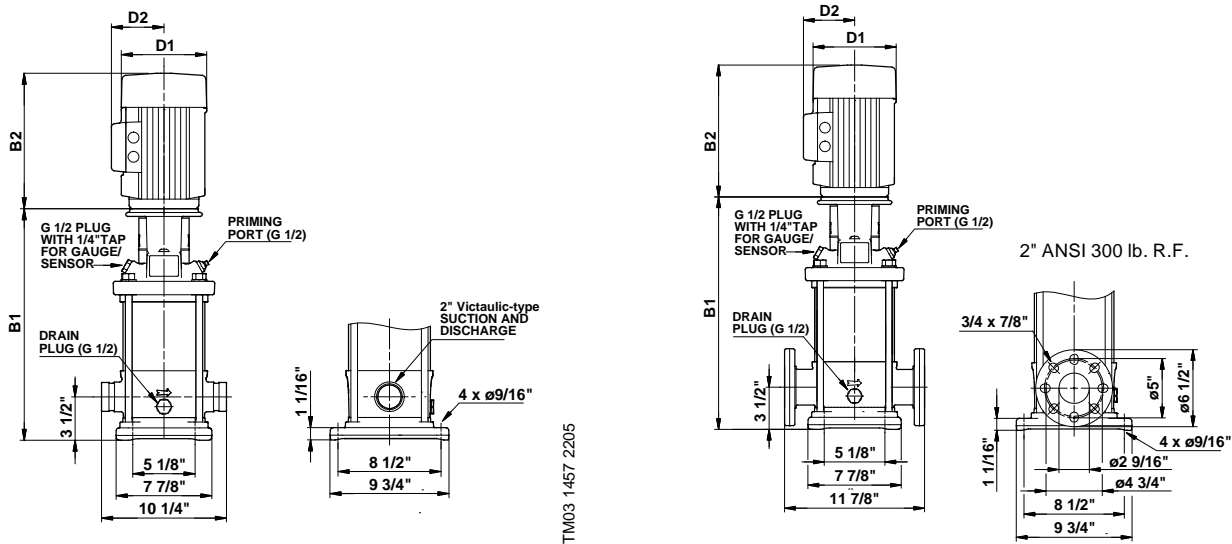

Pump type	P2 [hp]	Ph.	PJE*	ANSI dimensions [inch]						Ship Wt. [lbs.]	ANSI dimensions [inch]			Ship Wt. [lbs.]	
				B1	TEFC			ODP			MLE				
					D1	D2	B1+B2	D1	D2		B1+B2	D1	D2		B1+B2
CRN(E) 15-1	2	1	•	16.38	7.19	5.73	28.94	-	-	-	130	-	-	-	-
		3	•	16.38	7.01	4.33	27.60	-	-	-	121	7.01	6.57	29.18	135
CRN(E) 15-2	5	1	•	17.44	10.62	7.46	32.96	-	-	-	203	-	-	-	-
		3	•	17.13	8.66	5.28	32.64	-	-	-	195	8.66	7.40	29.93	185
CRN(E) 15-3	7 1/2	1	•	19.21	10.22	7.62	34.74	-	-	-	216	-	-	-	-
		3	•	19.21	8.66	5.28	34.72	-	-	-	205	8.66	7.40	19.21	200
CRN(E) 15-4	7 1/2	1	•	20.98	10.22	7.62	36.51	-	-	-	218	-	-	-	-
		3	•	20.98	8.66	5.28	36.49	-	-	-	207	8.66	7.40	34.29	221
CRN(E) 15-5	10	1	•	22.76	10.23	10.30	38.83	-	-	-	335	-	-	-	-
		3	•	22.76	8.66	5.28	38.27	-	-	-	214	10.24	8.39	22.76	232
CRN(E) 15-6	15	3	•	27.05	10.22	8.67	43.63	10.62	7.33	43.36	365	13.39	12.13	45.83	477
CRN 15-7	15	3	•	28.82	10.22	8.67	45.40	10.62	7.33	45.13	398	-	-	-	-
CRN(E) 15-8	15	3	•	30.59	10.22	8.67	47.17	10.62	7.33	46.90	431	13.39	12.13	49.37	495
CRN 15-9	20	3	•	32.36	10.22	8.67	48.94	11.50	8.92	52.05	439	-	-	-	-
CRN(E) 15-10	20	3	•	34.13	10.22	8.67	50.71	11.50	8.92	53.82	442	13.39	12.13	52.91	510
CRN(E) 15-12	25	3	•	37.05	12.94	11.52	56.87	11.50	8.94	57.86	496	13.39	12.13	59.77	543

All dimensions in inches unless otherwise noted.

\*PJE flanged pump B1 and B1+B2 dimension is equal to ANSI flanged pump and weight is approximately 9 lbs. less.

• Available.

## CR(E), CRI(E), CRN(E) 20

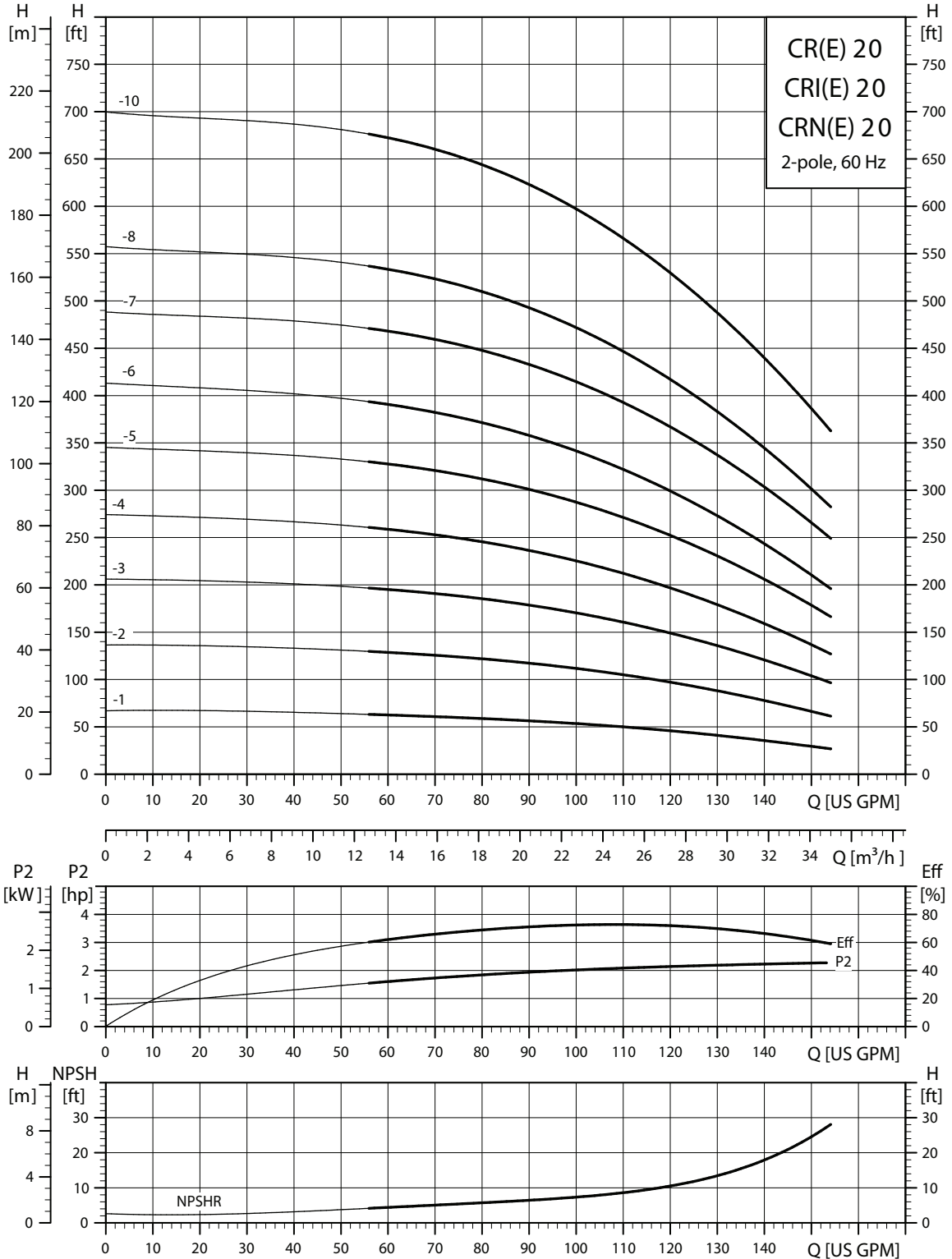

TM02 7223 2803

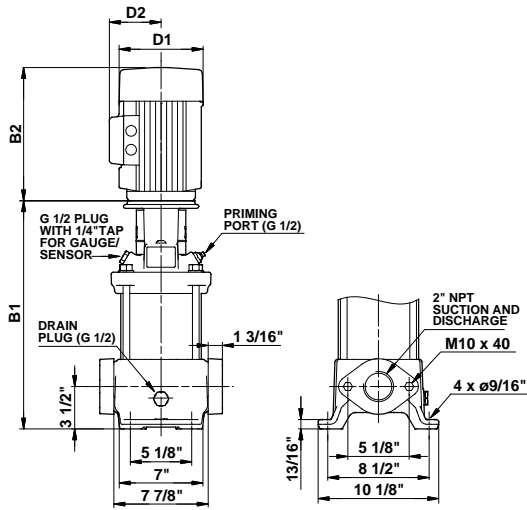

TM03 1460 2205

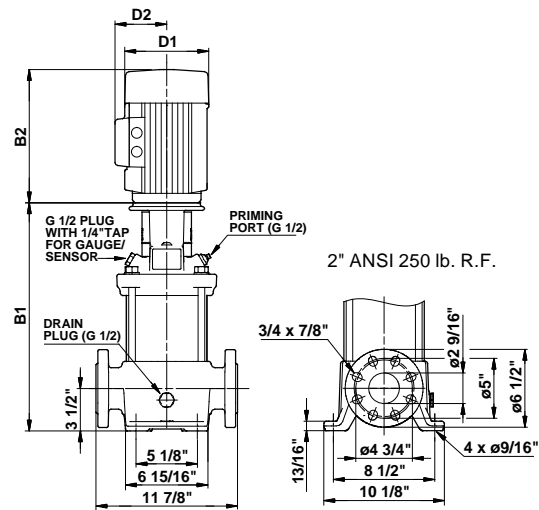

TM03 1461 2205

Pump type	P2 [hp]	Ph.	Dimensions [inch]							Ship Wt. [lbs.]	Dimensions [inch]			Ship Wt. [lbs.]	
			Oval*	B1	TEFC			ODP			MLE				
					D1	D2	B1+B2	D1	D2		B1+B2	D1	D2		B1+B2
CR(E) 20-1	3	1	•	17.20	8.60	6.87	31.85	-	-	-	181	-	-	-	-
		3	•	17.20	7.01	4.33	30.43	-	-	-	151	7.01	6.57	30.00	161
CR(E) 20-2	5	1	•	17.20	10.62	7.46	32.72	-	-	-	205	-	-	-	-
		3	•	17.20	8.66	5.28	32.71	-	-	-	201	8.66	7.40	30.00	194
CR(E) 20-3	7 1/2	1	•	19.29	10.22	7.62	34.82	-	-	-	223	-	-	-	-
		3	•	19.29	8.66	5.28	34.80	-	-	-	209	8.66	7.40	19.29	223
CR(E) 20-4	10	1	•	21.06	10.23	10.30	37.13	-	-	-	337	-	-	-	-
		3	•	21.06	8.66	5.28	36.57	-	-	-	214	10.24	8.39	34.37	232
CR(E) 20-5	15	3	•	25.39	10.22	8.67	41.97	10.62	7.33	41.70	398	13.39	12.13	44.17	488
CR(E) 20-6	15	3	•	27.17	10.22	8.67	43.75	10.62	7.33	43.48	402	13.39	12.13	45.95	491
CR 20-7	20	3	•	28.94	10.22	8.67	45.52	11.50	8.92	48.63	438	-	-	-	-
CR(E) 20-8	20	3	-	30.71	10.22	8.67	47.29	11.50	8.92	50.40	442	13.39	12.13	49.49	508
CR(E) 20-10	25	3	-	33.62	12.94	11.52	53.44	11.50	8.94	54.43	496	13.39	12.13	56.34	543

All dimensions in inches unless otherwise noted.

\*Oval flanged pump B1 and B1+B2 dimension is equal to ANSI flanged pumps and weight is approximately 3 lbs. less.

• Available.

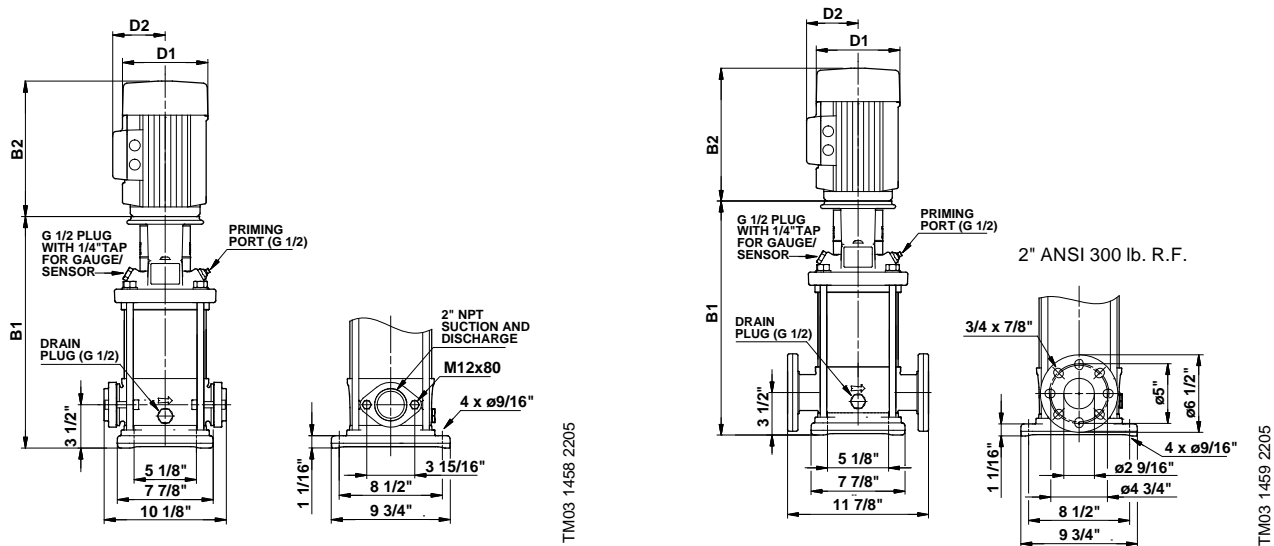

Pump type	P2 [hp]	Ph.	ANSI dimensions [inch]									Ship Wt. [lbs.]	ANSI dimensions [inch]			
			Oval*	B1	TEFC			ODP			MLE			Ship Wt. [lbs.]		
					D1	D2	B1+B2	D1	D2	B1+B2	D1		D2		B1+B2	
CRI(E) 20-1	3	1	•	17.13	8.60	6.87	31.78	-	-	-	174	-	-	-	-	
		3	•	17.13	7.01	4.33	30.36	-	-	-	145	7.01	6.57	29.93	152	
CRI(E) 20-2	5	1	•	17.13	10.62	7.46	32.65	-	-	-	198	-	-	-	-	
		3	•	17.13	8.66	5.28	32.64	-	-	-	195	8.66	7.40	29.93	185	
CRI(E) 20-3	7 1/2	1	•	19.21	10.22	7.62	34.74	-	-	-	216	-	-	-	-	
		3	•	19.21	8.66	5.28	34.72	-	-	-	203	8.66	7.40	19.21	216	
CRI(E) 20-4	10	1	•	20.98	10.23	10.30	37.05	-	-	-	331	-	-	-	-	
		3	•	20.98	8.66	5.28	36.49	-	-	-	205	10.24	8.39	34.29	223	
CRI(E) 20-5	15	3	•	25.28	10.22	8.67	41.86	10.62	7.33	41.59	391	13.39	12.13	44.06	480	
CRI(E) 20-6	15	3	•	27.05	10.22	8.67	43.63	10.62	7.33	43.36	396	13.39	12.13	45.83	484	
CRI 20-7	20	3	•	28.82	10.22	8.67	45.40	11.50	8.92	48.51	431	-	-	-	-	
CRI(E) 20-8	20	3	-	30.59	10.22	8.67	47.17	11.50	8.92	50.28	435	13.39	12.13	49.37	501	
CRI(E) 20-10	25	3	-	33.50	12.94	11.52	53.32	11.50	8.94	54.31	490	13.39	12.13	56.22	537	

All dimensions in inches unless otherwise noted.

\*Oval flanged pump B1 and B1+B2 dimension is equal to ANSI flanged pumps and weight is approximately 7 lbs. less.

• Available.



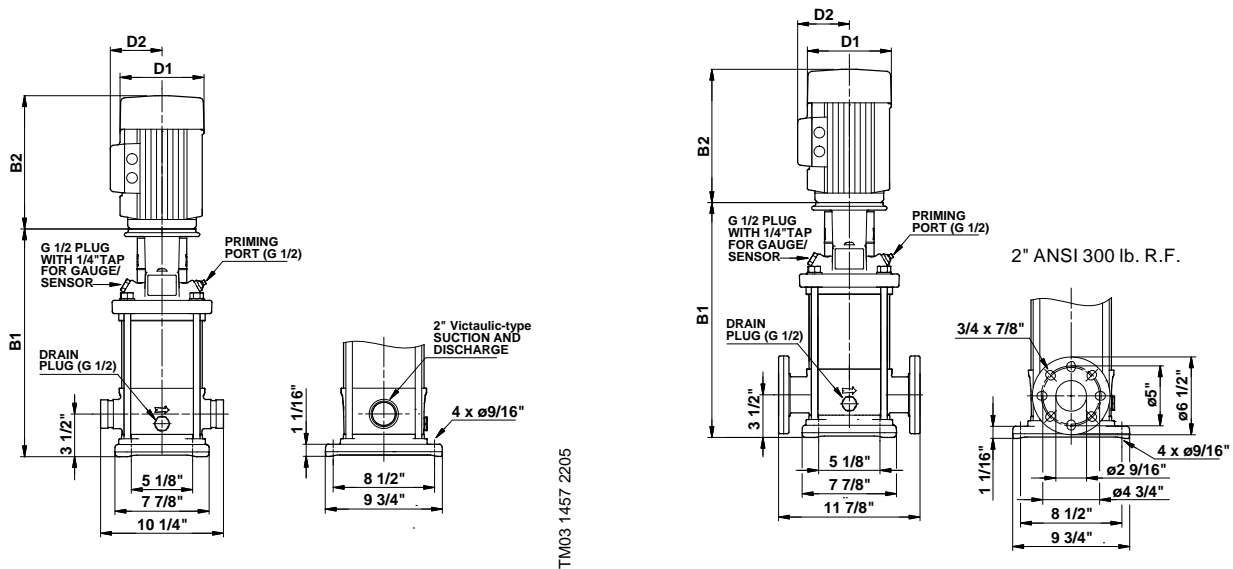

TM03 1457 2205

TM03 1459 2205

Pump type	P2 [hp]	Ph.	Dimensions [inch]									Ship Wt. [lbs.]	Dimensions [inch]			Ship Wt. [lbs.]
			PJE*	B1	TEFC			ODP			MLE					
					D1	D2	B1+B2	D1	D2	B1+B2	D1		D2	B1+B2		
CRN(E) 20-1	3	1	•	17.13	8.60	6.87	31.78	-	-	-	-	-	-	-	-	
			•	17.13	7.01	4.33	30.36	-	-	-	7.01	6.57	29.93	154		
CRN(E) 20-2	5	1	•	17.13	10.62	7.46	32.65	-	-	-	-	-	-	-		
			•	17.13	8.66	5.28	32.64	-	-	-	8.66	7.40	29.93	185		
CRN(E) 20-3	7 1/2	1	•	19.21	10.22	7.62	34.74	-	-	-	-	-	-	-		
			•	19.21	8.66	5.28	34.72	-	-	-	8.66	7.40	19.21	216		
CRN(E) 20-4	10	1	•	20.98	10.23	10.30	37.05	-	-	-	-	-	-	-		
			•	20.98	8.66	5.28	36.49	-	-	-	10.24	8.39	34.29	225		
CRN(E) 20-5	15	3	•	25.28	10.22	8.67	41.86	10.62	7.33	41.59	394	13.39	12.13	44.06	480	
CRN(E) 20-6	15	3	•	27.05	10.22	8.67	43.63	10.62	7.33	43.36	396	13.39	12.13	45.83	484	
CRN 20-7	20	3	•	28.82	10.22	8.67	45.40	11.50	8.92	48.51	431	-	-	-	-	
CRN(E) 20-8	20	3	•	30.59	10.22	8.67	47.17	11.50	8.92	50.28	435	13.39	12.13	49.37	501	
CRN(E) 20-10	25	3	•	33.50	12.94	11.52	53.32	11.50	8.94	54.31	490	13.39	12.13	56.22	537	

All dimensions in inches unless otherwise noted.

\*PJE flanged pump B1 and B1+B2 dimension is equal to ANSI flanged pumps and weight is approximately 9 lbs. less.

• Available.

## CR(E), CRN(E) 32

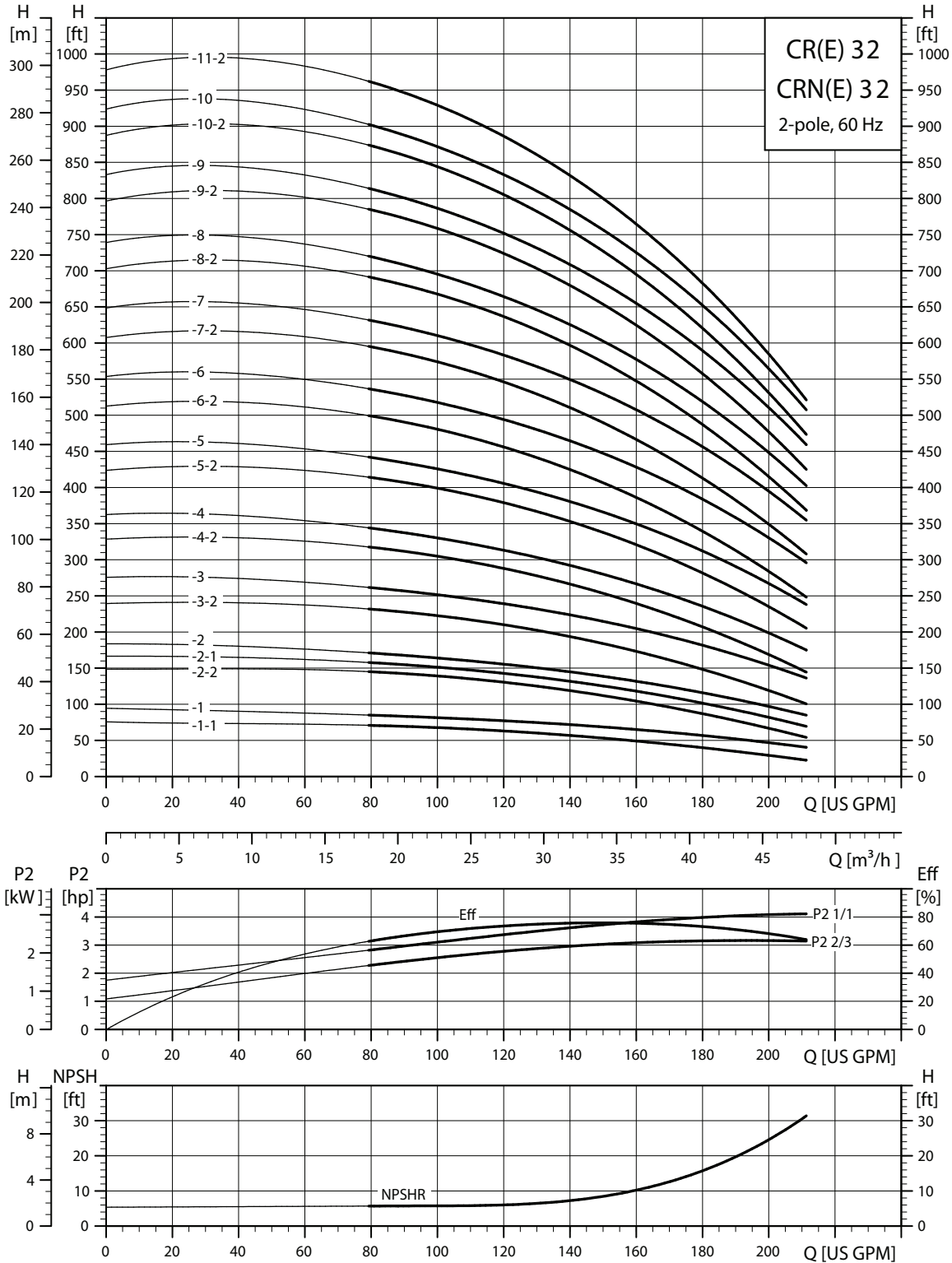

TM02 0039 1303

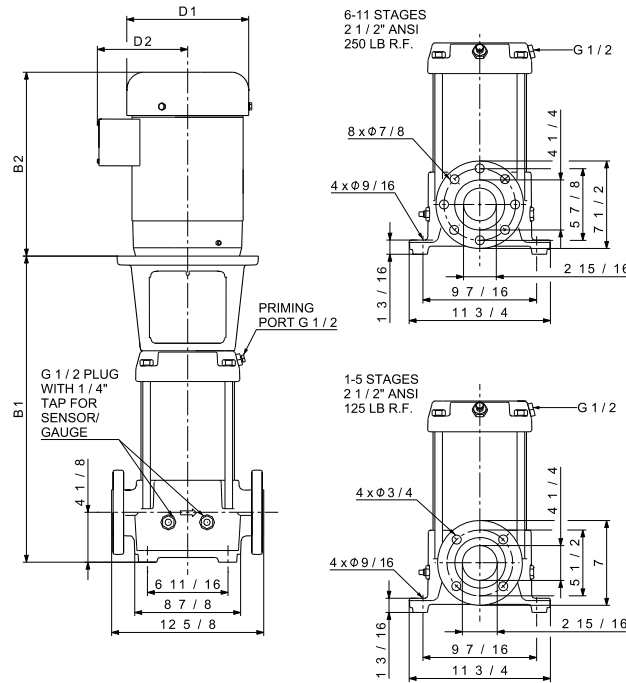

TM02 7699 1009

Pump type	P2 [hp]	Ph.	ANSI dimensions [inch]						Ship Wt. [lbs.]	ANSI dimensions [inch]			Ship Wt. [lbs.]	
			B1	TEFC			ODP			MLE				
				D1	D2	B1+B2	D1	D2		B1+B2	D1	D2		B1+B2
CR 32-1-1	5	1	20.08	10.62	7.46	35.60	-	-	-	240	-	-	-	-
		3	19.88	8.66	5.28	35.39	-	-	-	218	-	-	-	-
CR(E) 32-1	5	1	20.08	10.62	7.46	35.60	-	-	-	228	-	-	-	-
		3	19.88	8.66	5.28	35.39	-	-	-	218	8.66	7.40	35.39	210
CR 32-2-2	7 1/2	1	22.83	10.22	7.62	38.36	-	-	-	245	-	-	-	-
		3	22.64	8.66	5.28	38.15	-	-	-	229	-	-	-	-
CR(E) 32-2-1	7 1/2	1	22.83	10.22	7.62	38.36	-	-	-	245	-	-	-	-
		3	22.64	8.66	5.28	38.15	-	-	-	229	8.66	7.40	38.15	242
CR 32-2	10	1	22.83	10.23	10.30	38.90	-	-	-	300	-	-	-	-
		3	22.64	8.66	5.28	38.15	-	-	-	229	-	-	-	-
CR(E) 32-3-2	10	1	25.59	10.23	10.30	41.66	-	-	-	295	-	-	-	-
		3	25.39	8.66	5.28	40.90	-	-	-	236	10.24	8.39	40.31	256
CR 32-3	15	3	29.72	10.22	8.67	46.30	10.62	7.33	46.03	361	-	-	-	-
CR(E) 32-4-2	15	3	32.48	10.22	8.67	49.06	10.62	7.33	48.79	368	13.39	12.13	51.26	541
CR 32-4	20	3	32.48	10.22	8.67	49.06	11.50	8.92	52.17	373	-	-	-	-
CR(E) 32-5-2	20	3	35.24	10.22	8.67	51.82	11.50	8.92	54.93	380	13.39	12.13	54.02	552
CR(E) 32-5	20	3	35.24	10.22	8.67	51.82	11.50	8.92	54.93	380	13.39	12.13	54.02	552
CR 32-6-2	25	3	37.99	12.94	11.52	57.81	11.50	8.94	58.80	434	-	-	-	-
CR(E) 32-6	25	3	37.99	12.94	11.52	57.81	11.50	8.94	58.80	434	13.39	12.13	60.71	624
CR 32-7-2	30	3	40.75	15.32	13.11	63.94	11.50	8.94	62.56	623	-	-	-	-
CR(E) 32-7	30	3	40.75	15.32	13.11	63.94	11.50	8.94	62.56	602	13.39	12.13	63.47	657
CR(E) 32-8-2	30	3	43.5	15.32	13.11	66.69	11.50	8.94	65.31	615	13.39	12.13	66.22	670
CR 32-8	40	3	43.5	15.32	13.11	66.69	13.25	12.21	66.75	631	-	-	-	-
CR 32-9-2	40	3	46.26	15.32	13.11	69.45	13.25	12.21	69.51	637	-	-	-	-
CR 32-9	40	3	46.26	15.32	13.11	69.45	13.25	12.21	69.51	637	-	-	-	-
CR 32-10-2	40	3	49.02	15.32	13.11	72.21	13.25	12.21	72.27	645	-	-	-	-
CR 32-10	40	3	49.02	15.32	13.11	72.21	13.25	12.21	72.27	645	-	-	-	-
CR 32-11-2	50	3	51.77	16.88	14.12	79.58	13.25	12.21	74.52	671	-	-	-	-

<sup>1)</sup> Weights are based on pump with TEFC motor (see price list for individual weights).  
All dimensions in inches unless otherwise noted.

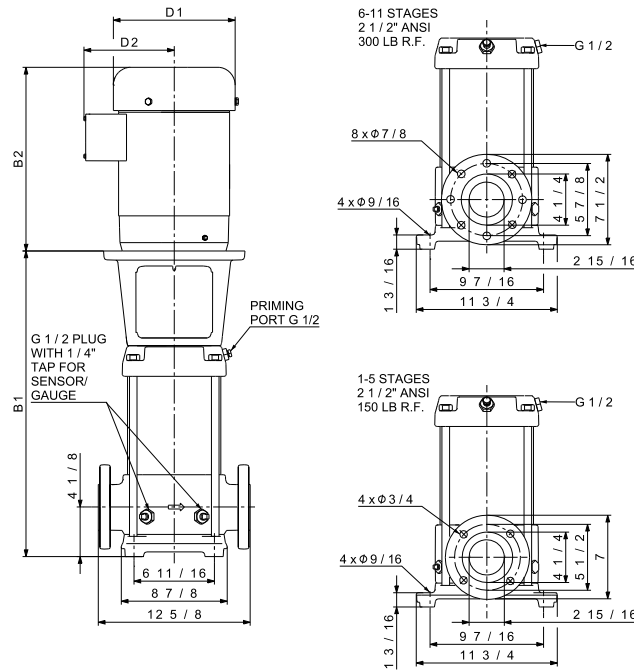

TM02 7703 1009

Pump type	P2 [hp]	Ph.	ANSI dimensions [inch]						Ship Wt. [lbs.]	ANSI dimensions [inch]			Ship Wt. [lbs.]	
			B1	TEFC			ODP			MLE				
				D1	D2	B1+B2	D1	D2		B1+B2	D1	D2		B1+B2
CRN 32-1-1	5	1	20.08	10.62	7.46	35.60	-	-	-	245	-	-	-	-
		3	19.88	8.66	5.28	35.39	-	-	-	223	-	-	-	-
CRN(E) 32-1	5	1	20.08	10.62	7.46	35.60	-	-	-	233	-	-	-	-
		3	19.88	8.66	5.28	35.39	-	-	-	223	8.66	7.40	35.39	214
CRN 32-2-2	7 1/2	1	22.83	10.22	7.62	38.36	-	-	-	250	-	-	-	-
		3	22.64	8.66	5.28	38.15	-	-	-	234	-	-	-	-
CRN(E) 32-2-1	7 1/2	1	22.83	10.22	7.62	38.36	-	-	-	250	-	-	-	-
		3	22.64	8.66	5.28	38.15	-	-	-	234	8.66	7.40	38.15	247
CRN 32-2	10	1	22.83	10.23	10.30	38.90	-	-	-	305	-	-	-	-
		3	22.64	8.66	5.28	38.15	-	-	-	234	-	-	-	-
CRN(E) 32-3-2	10	1	25.59	10.23	10.30	41.66	-	-	-	300	-	-	-	-
		3	25.39	8.66	5.28	40.90	-	-	-	241	10.24	8.39	40.31	259
CRN 32-3	15	3	29.72	10.22	8.67	46.30	10.62	7.33	46.03	366	-	-	-	-
CRN(E) 32-4-2		3	32.48	10.22	8.67	49.06	10.62	7.33	48.79	372	13.39	12.13	51.26	546
CRN 32-4	20	3	32.48	10.22	8.67	49.06	11.50	8.92	52.17	377	-	-	-	-
CRN(E) 32-5-2		3	35.24	10.22	8.67	51.82	11.50	8.92	54.93	384	13.39	12.13	54.02	556
CRN(E) 32-5	20	3	35.24	10.22	8.67	51.82	11.50	8.92	54.93	384	13.39	12.13	54.02	556
CRN 32-6-2		25	3	37.99	12.94	11.52	57.81	11.50	8.94	58.80	438	-	-	-
CRN(E) 32-6	3		37.99	12.94	11.52	57.81	11.50	8.94	58.80	438	13.39	12.13	60.71	628
CRN 32-7-2	30	3	40.75	15.32	13.11	63.94	11.50	8.94	62.56	627	-	-	-	-
CRN(E) 32-7		3	40.75	15.32	13.11	63.94	11.50	8.94	62.56	606	13.39	12.13	63.47	661
CRN(E) 32-8-2	30	3	43.5	15.32	13.11	66.69	11.50	8.94	65.31	619	13.39	12.13	66.22	674
CRN 32-8		40	3	43.5	15.32	13.11	66.69	13.25	12.21	66.75	635	-	-	-
CRN 32-9-2	40		3	46.26	15.32	13.11	69.45	13.25	12.21	69.51	641	-	-	-
CRN 32-9		40	3	46.26	15.32	13.11	69.45	13.25	12.21	69.51	641	-	-	-
CRN 32-10-2	40		3	49.02	15.32	13.11	72.21	13.25	12.21	72.27	648	-	-	-
CRN 32-10		40	3	49.02	15.32	13.11	72.21	13.25	12.21	72.27	648	-	-	-
CRN 32-11-2	50		3	51.77	16.88	14.12	79.58	13.25	12.21	74.52	674	-	-	-

1) Weights are based on pump with TEFC motor (see price list for individual weights)  
All dimensions in inches unless otherwise noted.

## CR(E), CRN(E) 45

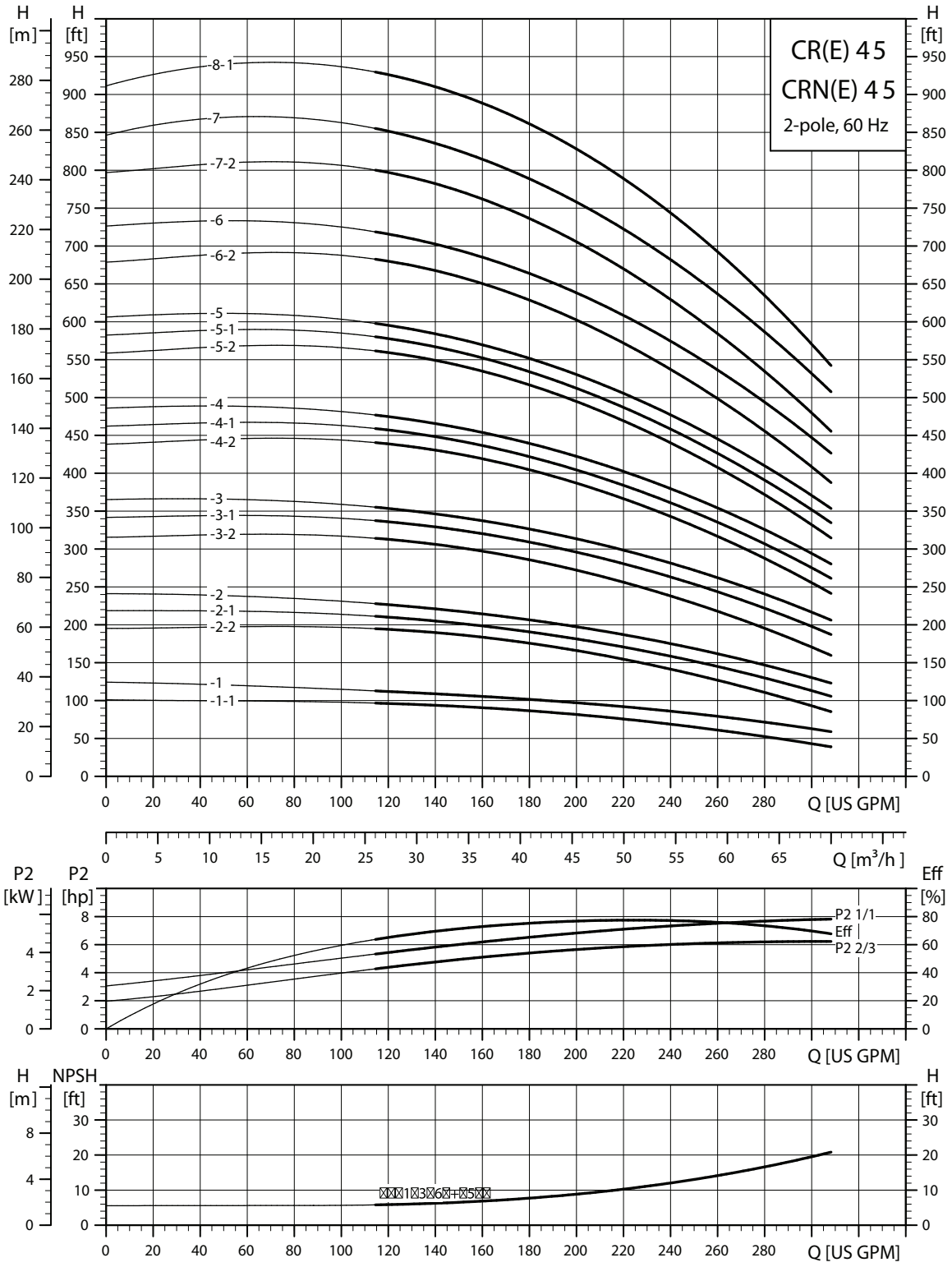

TM02 0040 1303

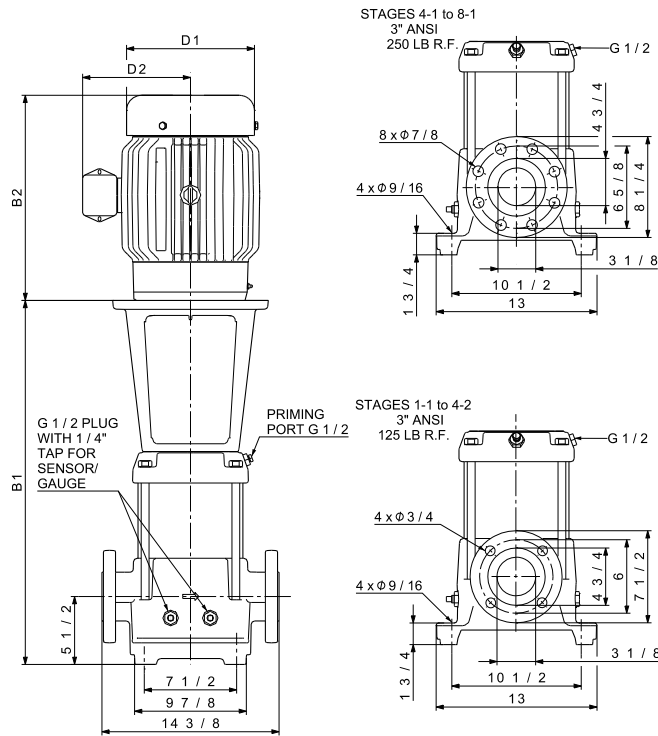

TM02 7700 1009

Pump type	P2 [hp]	Ph.	ANSI dimensions [inch]							Ship Wt. [lbs.]	ANSI dimensions [inch]			Ship Wt. [lbs.]
			B1	TEFC			ODP				MLE			
				D1	D2	B1+B2	D1	D2	B1+B2		D1	D2	B1+B2	
CR(E) 45-1-1	7 1/2	1	22.20	10.22	7.62	37.73	-	-	-	259	-	-	-	-
		3	22.01	8.66	5.28	37.52	-	-	-	243	8.66	7.40	37.52	256
CR(E) 45-1	10	1	22.20	10.23	10.30	38.27	-	-	-	314	-	-	-	-
		3	22.01	8.66	5.28	37.52	-	-	-	243	10.24	8.39	36.93	265
CR(E) 45-2-2	15	3	29.49	10.22	8.67	46.07	10.62	7.33	45.80	376	13.39	12.13	48.27	549
CR 45-2-1	15	3	29.49	10.22	8.67	46.07	10.62	7.33	45.80	376	-	-	-	-
CR(E) 45-2	15	3	29.49	10.22	8.67	46.07	10.62	7.33	45.80	376	13.39	12.13	48.27	549
CR(E) 45-3-2	20	3	32.64	10.22	8.67	49.22	11.50	8.92	52.33	390	13.39	12.13	51.42	562
CR 45-3-1	25	3	32.64	12.94	11.52	52.46	11.50	8.94	53.45	436	-	-	-	-
CR(E) 45-3	25	3	32.64	12.94	11.52	52.46	11.50	8.94	53.45	436	13.39	12.13	55.36	589
CR(E) 45-4-2	30	3	35.79	15.32	13.11	58.98	11.50	8.94	57.60	605	13.39	12.13	58.51	660
CR 45-4-1	30	3	35.79	15.32	13.11	58.98	11.50	8.94	57.60	611	-	-	-	-
CR(E) 45-4	30	3	35.79	15.32	13.11	58.98	11.50	8.94	57.60	611	13.39	12.13	58.51	666
CR 45-5-2	40	3	38.94	15.32	13.11	62.13	13.25	12.21	62.19	634	-	-	-	-
CR 45-5-1	40	3	38.94	15.32	13.11	62.13	13.25	12.21	62.19	634	-	-	-	-
CR 45-5	40	3	38.94	15.32	13.11	62.13	13.25	12.21	62.19	634	-	-	-	-
CR 45-6-2	50	3	42.09	16.88	14.12	69.90	13.25	12.21	64.84	679	-	-	-	-
CR 45-6	50	3	42.09	16.88	14.12	69.90	13.25	12.21	64.84	679	-	-	-	-
CR 45-7-2	50	3	45.24	16.88	14.12	73.05	13.25	12.21	67.99	689	-	-	-	-
CR 45-7	60	3	45.24	19.00	14.90	76.03	15.12	13.19	71.37	869	-	-	-	-
CR 45-8-1	60	3	48.39	19.00	14.90	79.18	15.12	13.19	74.52	878	-	-	-	-

<sup>1)</sup> Weights are based on pump with TEFC motor (see price list for individual weights)  
All dimensions in inches unless otherwise noted.

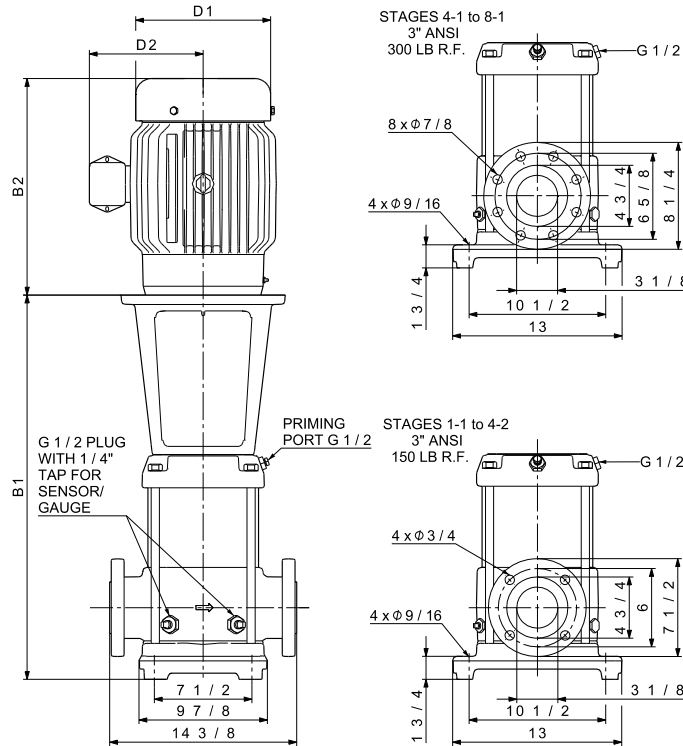

TM02 7704 1009

Pump type	P2 [hp]	Ph.	ANSI dimensions [inch]							Ship Wt. [lbs.]	ANSI dimensions [inch]			Ship Wt. [lbs.]
			B1	TEFC			ODP				MLE			
				D1	D2	B1+B2	D1	D2	B1+B2		D1	D2	B1+B2	
CRN(E) 45-1-1	7 1/2	1	22.20	10.22	7.62	37.73	-	-	-	259	-	-	-	-
		3	22.01	8.66	5.28	37.52	-	-	-	243	220.00	188.00	37.52	256
CRN(E) 45-1	10	1	22.20	10.23	10.30	38.27	-	-	-	314	-	-	-	-
		3	22.01	8.66	5.28	37.52	-	-	-	243	260.00	213.00	36.93	265
CRN(E) 45-2-2	15	3	29.49	10.22	8.67	46.07	10.62	7.33	45.80	376	13.39	12.13	48.27	550
CRN 45-2-1	15	3	29.49	10.22	8.67	46.07	10.62	7.33	45.80	376	-	-	-	-
CRN(E) 45-2	15	3	29.49	10.22	8.67	46.07	10.62	7.33	45.80	376	13.39	12.13	48.27	550
CRN(E) 45-3-2	20	3	32.64	10.22	8.67	49.22	11.50	8.92	52.33	390	13.39	12.13	51.42	562
CRN 45-3-1	25	3	32.64	12.94	11.52	52.46	11.50	8.94	53.45	436	-	-	-	-
CRN(E) 45-3	25	3	32.64	12.94	11.52	52.46	11.50	8.94	53.45	436	13.39	12.13	55.36	590
CRN(E) 45-4-2	30	3	35.79	15.32	13.11	58.98	11.50	8.94	57.60	606	13.39	12.13	58.51	661
CRN 45-4-1	30	3	35.79	15.32	13.11	58.98	11.50	8.94	57.60	609	-	-	-	-
CRN(E) 45-4	30	3	35.79	15.32	13.11	58.98	11.50	8.94	57.60	609	13.39	12.13	58.51	664
CRN 45-5-2	40	3	38.94	15.32	13.11	62.13	13.25	12.21	62.19	632	-	-	-	-
CRN 45-5-1	40	3	38.94	15.32	13.11	62.13	13.25	12.21	62.19	632	-	-	-	-
CRN 45-5	40	3	38.94	15.32	13.11	62.13	13.25	12.21	62.19	632	-	-	-	-
CRN 45-6-2	50	3	42.09	16.88	14.12	69.90	13.25	12.21	64.84	677	-	-	-	-
CRN 45-6	50	3	42.09	16.88	14.12	69.90	13.25	12.21	64.84	677	-	-	-	-
CRN 45-7-2	50	3	45.24	16.88	14.12	73.05	13.25	12.21	67.99	687	-	-	-	-
CRN 45-7	60	3	45.24	19.00	14.90	76.03	15.12	13.19	71.37	867	-	-	-	-
CRN 45-8-1	60	3	48.39	19.00	14.90	79.18	15.12	13.19	74.52	876	-	-	-	-

1) Weights are based on pump with TEFC motor (see price list for individual weights)  
All dimensions in inches unless otherwise noted.

## CR(E), CRN(E) 64

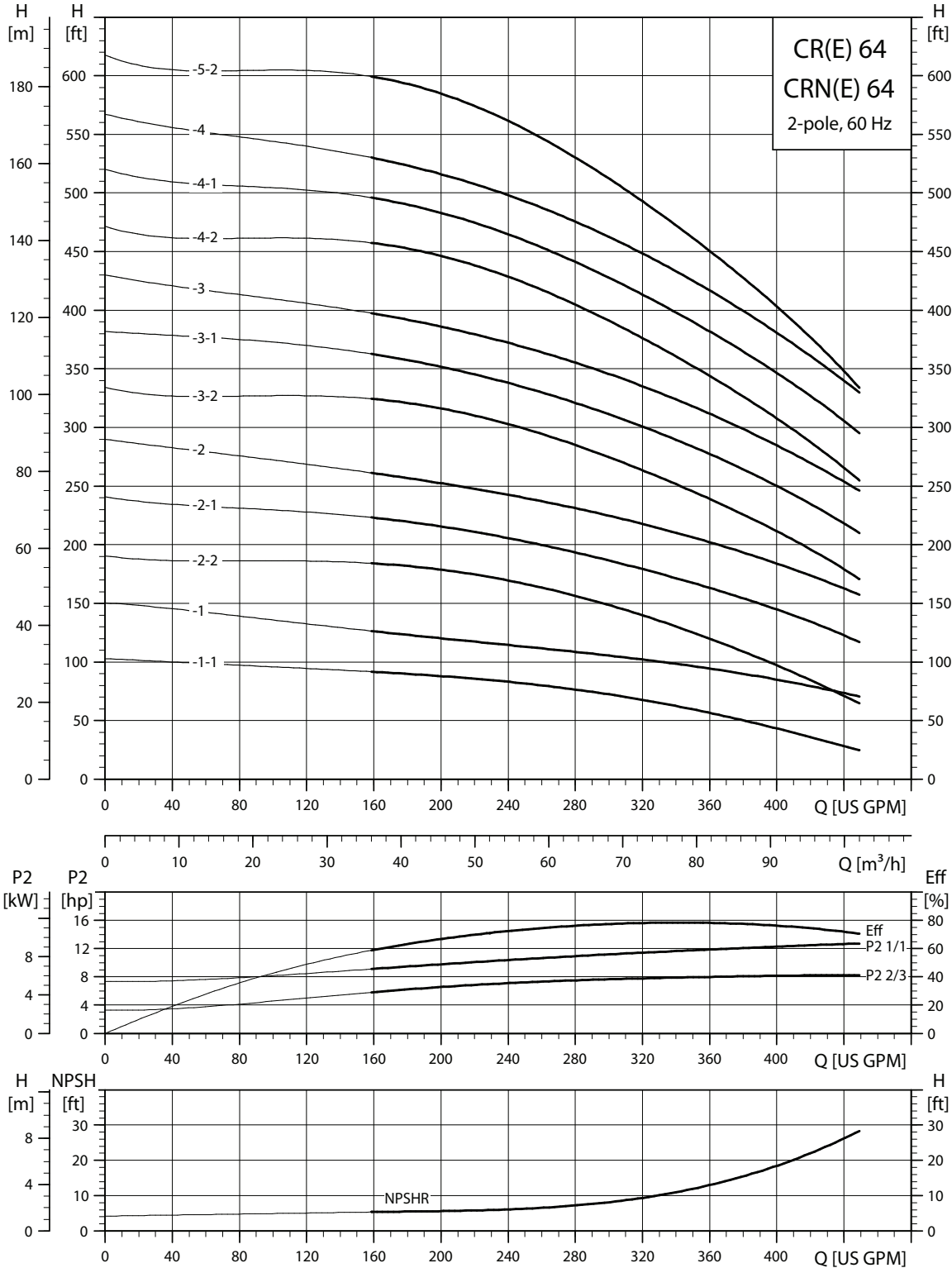

TM02 0041 3804



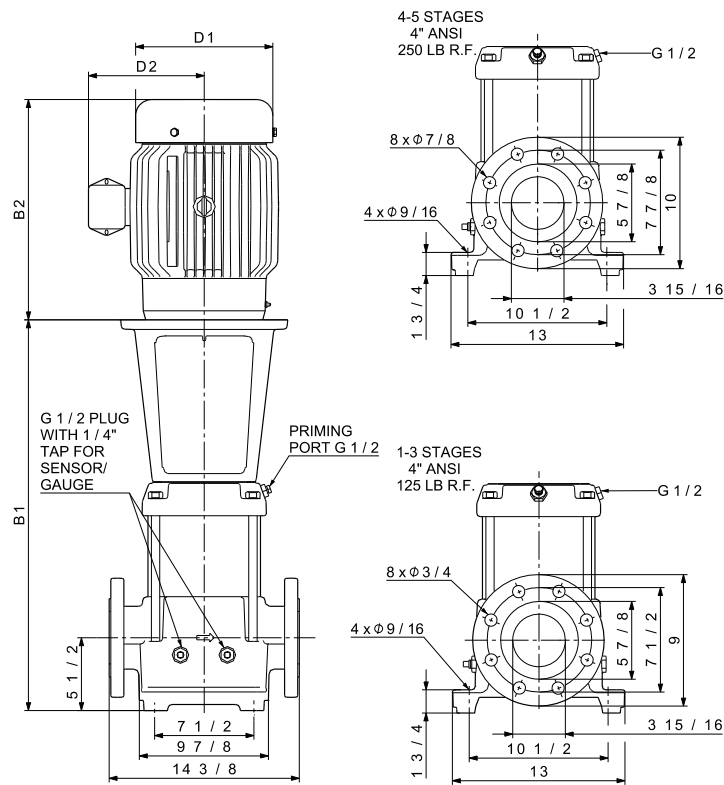

TM02 7701 1009

Pump type	P2 [hp]	Ph.	Dimensions [inch]							Ship Wt. [lbs.]	Dimensions [inch]			Ship Wt. [lbs.]
			B1	TEFC			ODP				MLE			
				D1	D2	B1+B2	D1	D2	B1+B2		D1	D2	B1+B2	
CR(E) 64-1-1	10	1	22.09	10.23	10.30	38.16	-	-	-	268	-	-	-	-
		3	22.09	8.66	5.28	37.60	-	-	-	252	10.24	8.39	37.01	274
CR(E) 64-1	15	3	26.42	10.22	8.67	43.00	10.62	7.33	42.73	377	13.39	12.13	45.20	533
CR 64-2-2	20	3	29.69	10.22	8.67	46.27	11.50	8.92	49.38	392	-	-	-	-
CR(E) 64-2-1	20	3	29.69	10.22	8.67	46.27	11.50	8.92	49.38	392	13.39	12.13	48.47	564
CR(E) 64-2	25	3	29.69	12.94	11.52	49.51	11.50	8.94	50.50	438	13.39	12.13	52.41	593
CR(E) 64-3-2	30	3	32.91	15.32	13.11	56.10	11.50	8.94	54.72	609	13.39	12.13	55.63	664
CR 64-3-1	40	3	32.91	15.32	13.11	56.10	13.25	12.21	56.16	624	-	-	-	-
CR 64-3	40	3	32.91	15.32	13.11	56.10	13.25	12.21	56.16	624	-	-	-	-
CR 64-4-2	40	3	36.18	15.32	13.11	59.37	13.25	12.21	59.43	624	-	-	-	-
CR 64-4-1	50	3	36.18	16.88	14.12	63.99	13.25	12.21	58.93	676	-	-	-	-
CR 64-4	50	3	36.18	16.88	14.12	63.99	13.25	12.21	58.93	676	-	-	-	-
CR 64-5-2	60	3	39.41	19.00	14.90	70.20	15.12	13.19	65.54	866	-	-	-	-

<sup>1)</sup> Weights are based on pump with TEFC motor (see price list for individual weights)  
All dimensions in inches unless otherwise noted.

## Dimensional sketches

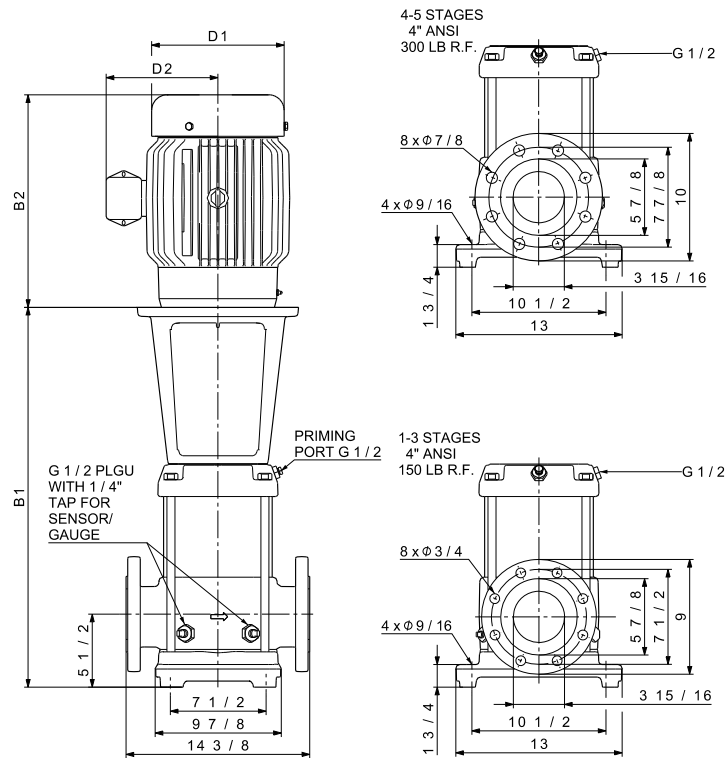

TM02 7705 1009

## Dimensions and weights

Pump type	P2 [hp]	Ph.	ANSI dimensions [inch]							Ship Wt. [lbs.]	ANSI dimensions [inch]			Ship Wt. [lbs.]
			B1	TEFC			ODP				MLE			
				D1	D2	B1+B2	D1	D2	B1+B2		D1	D2	B1+B2	
CRN(E) 64-1-1	10	1	22.09	10.23	10.30	38.16	-	-	-	269	-	-	-	-
		3	22.09	8.66	5.28	37.60	-	-	-	253	10.24	8.39	37.01	275
CRN(E) 64-1	15	3	26.42	10.22	8.67	43.00	10.62	7.33	42.73	378	13.39	12.13	45.20	535
CRN 64-2-2	20	3	29.69	10.22	8.67	46.27	11.50	8.92	49.38	393	-	-	-	-
CRN(E) 64-2-1	20	3	29.69	10.22	8.67	46.27	11.50	8.92	49.38	393	13.39	12.13	48.47	566
CRN(E) 64-2	25	3	29.69	12.94	11.52	49.51	11.50	8.94	50.50	440	13.39	12.13	52.41	595
CRN(E) 64-3-2	30	3	32.91	15.32	13.11	56.10	11.50	8.94	54.72	611	13.39	12.13	55.63	666
CRN 64-3-1	40	3	32.91	15.32	13.11	56.10	13.25	12.21	56.16	625	-	-	-	-
CRN 64-3	40	3	32.91	15.32	13.11	56.10	13.25	12.21	56.16	625	-	-	-	-
CRN 64-4-2	40	3	36.18	15.32	13.11	59.37	13.25	12.21	59.43	625	-	-	-	-
CRN 64-4-1	50	3	36.18	16.88	14.12	63.99	13.25	12.21	58.93	678	-	-	-	-
CRN 64-4	50	3	36.18	16.88	14.12	63.99	13.25	12.21	58.93	678	-	-	-	-
CRN 64-5-2	60	3	39.41	19.00	14.90	70.20	15.12	13.19	65.54	868	-	-	-	-

<sup>1)</sup> Weights are based on pump with TEFC motor (see price list for individual weights)  
All dimensions in inches unless otherwise noted.

## CR, CRN 90

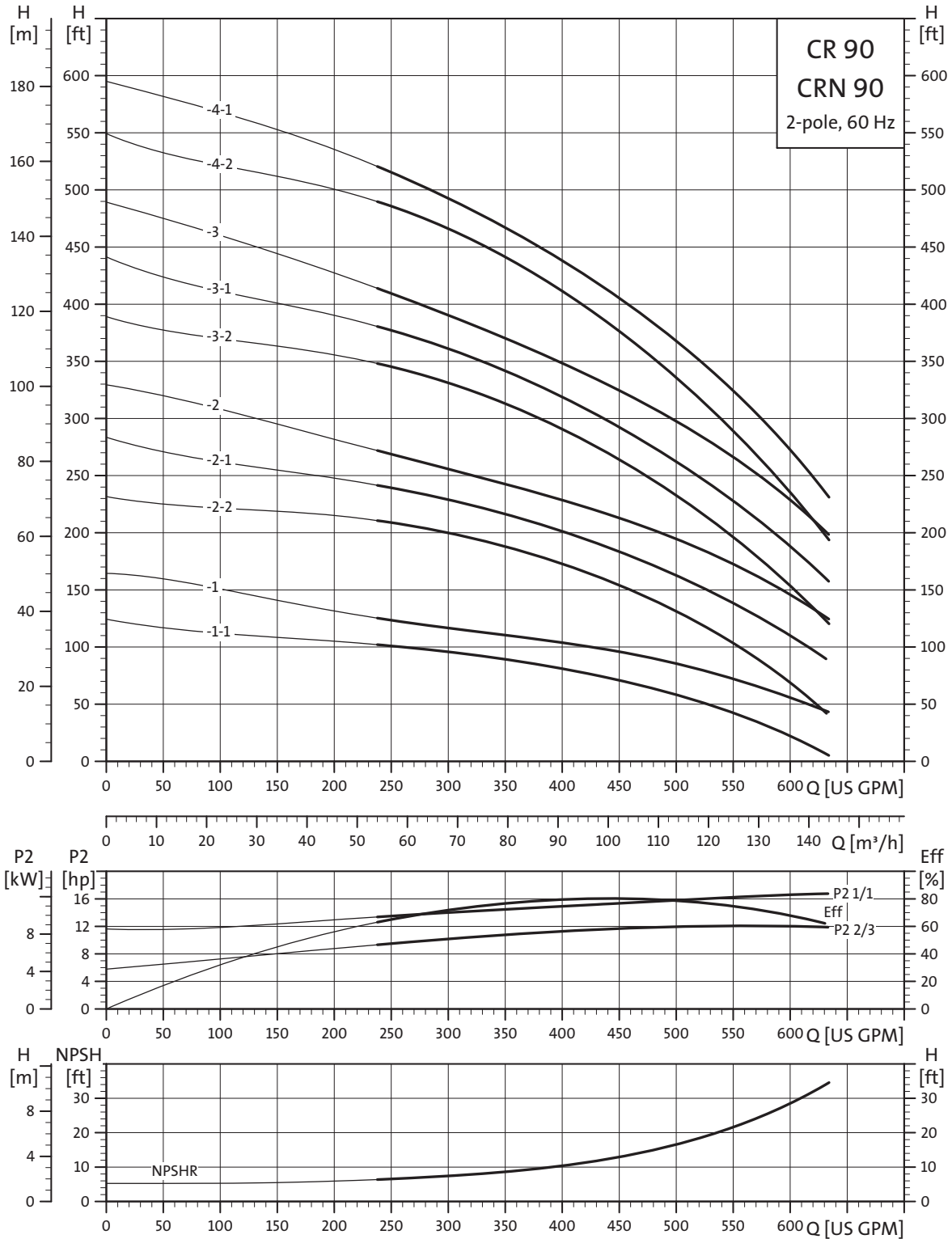

TM02 0042 1303

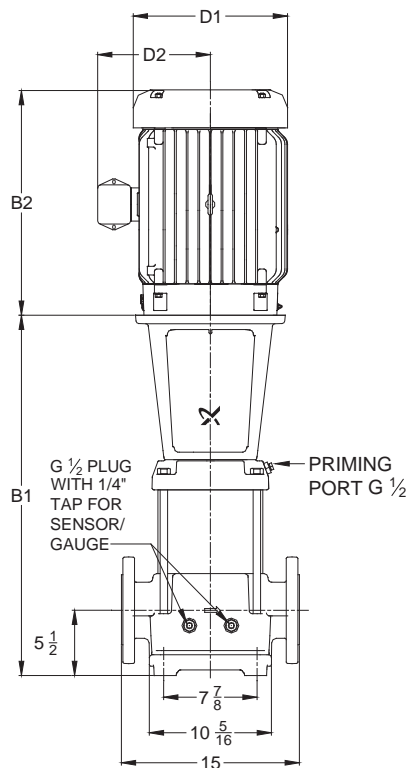

### 4-5 STAGES

4" ANSI  
250 LB R.F.

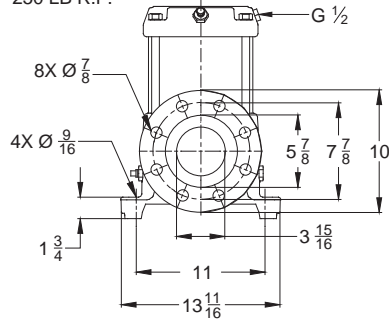

### 1-3 STAGES

4" ANSI  
125 LB R.F.

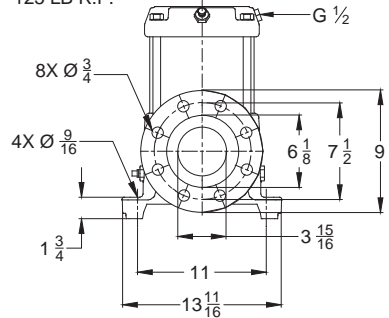

TM02 7702 3804

Pump type	P2 [hp]	Ph.	ANSI dimensions [inch]							Ship Wt. [lbs.]	ANSI dimensions [inch]			
			B1	TEFC			ODP				MLE			Ship Wt. [lbs.]
				D1	D2	B1+B2	D1	D2	B1+B2		D1	D2	B1+B2	
CR(E) 90-1-1	15	3	26.81	10.22	8.67	43.39	10.62	7.33	43.12	387	13.39	12.13	45.59	544
CR(E) 90-1	20	3	26.81	10.22	8.67	43.39	11.50	8.92	46.50	392	13.39	12.13	45.59	548
CR(E) 90-2-2	25	3	30.43	12.94	11.52	50.25	11.50	8.94	51.24	450	13.39	12.13	53.15	640
CR(E) 90-2-1	30	3	30.43	15.32	13.11	53.62	11.50	8.94	52.24	611	13.39	12.13	53.15	666
CR 90-2	40	3	30.43	15.32	13.11	53.62	13.25	12.21	53.68	625	-	-	-	-
CR 90-3-2	40	3	34.06	15.32	13.11	57.25	13.25	12.21	57.31	636	-	-	-	-
CR 90-3-1	50	3	34.06	16.88	14.12	61.87	13.25	12.21	56.81	667	-	-	-	-
CR 90-3	50	3	34.06	16.88	14.12	61.87	13.25	12.21	56.81	667	-	-	-	-
CR 90-4-2	60	3	37.68	19.00	14.90	68.47	15.12	13.19	63.81	869	-	-	-	-
CR 90-4-1	60	3	37.68	19.00	14.90	68.47	15.12	13.19	63.81	869	-	-	-	-

<sup>1)</sup> Weights are based on pump with TEFC motor (see price list for individual weights)  
All dimensions in inches unless otherwise noted.

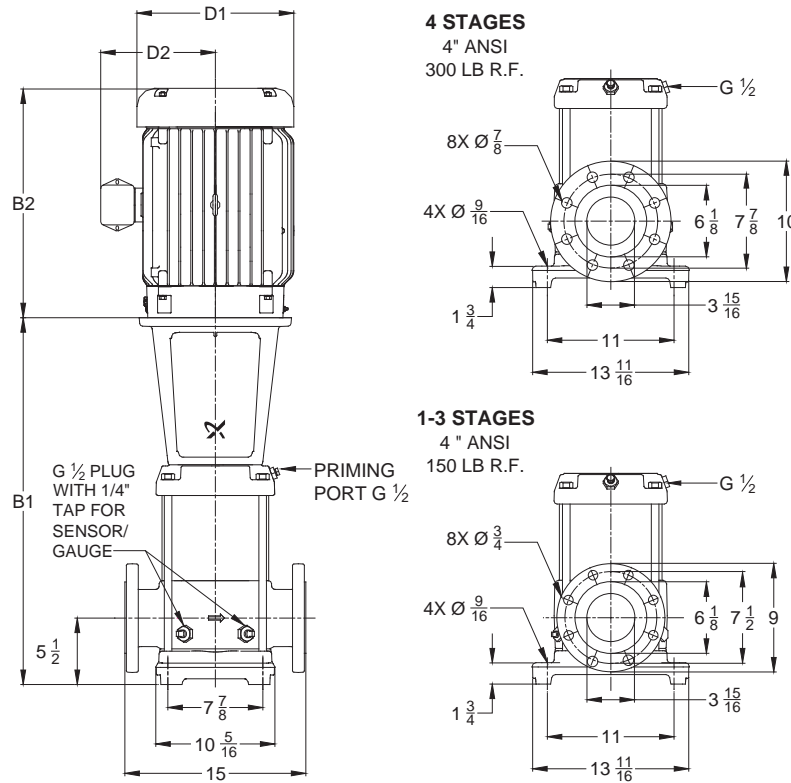

TM02 7706 3804

Pump type	P2 [hp]	Ph.	Dimensions [inch]							Ship Wt. [lbs.]	Dimensions [inch]			Ship Wt. [lbs.]
			B1	TEFC			ODP				MLE			
				D1	D2	B1+B2	D1	D2	B1+B2		D1	D2	B1+B2	
CRN(E) 90-1-1	15	3	26.81	10.22	8.67	43.39	10.62	7.33	43.12	393	13.39	12.13	45.59	549
CRN(E) 90-1	20	3	26.81	10.22	8.67	43.39	11.50	8.92	46.50	398	13.39	12.13	45.59	553
CRN(E) 90-2-2	25	3	30.43	12.94	11.52	50.25	11.50	8.94	51.24	455	13.39	12.13	53.15	645
CRN(E) 90-2-1	30	3	30.43	15.32	13.11	53.62	11.50	8.94	52.24	629	13.39	12.13	53.15	671
CRN 90-2	40	3	30.43	15.32	13.11	53.62	13.25	12.21	53.68	631	-	-	-	-
CRN 90-3-2	40	3	34.06	15.32	13.11	57.25	13.25	12.21	57.31	642	-	-	-	-
CRN 90-3-1	50	3	34.06	16.88	14.12	61.87	13.25	12.21	56.81	668	-	-	-	-
CRN 90-3	50	3	34.06	16.88	14.12	61.87	13.25	12.21	56.81	672	-	-	-	-
CRN 90-4-2	60	3	37.68	19.00	14.90	68.47	15.12	13.19	63.81	876	-	-	-	-
CRN 90-4-1	60	3	37.68	19.00	14.90	68.47	15.12	13.19	63.81	876	-	-	-	-

<sup>1)</sup> Weights are based on pump with TEFC motor (see price list for individual weights)  
All dimensions in inches unless otherwise noted.

## CR, CRN 120

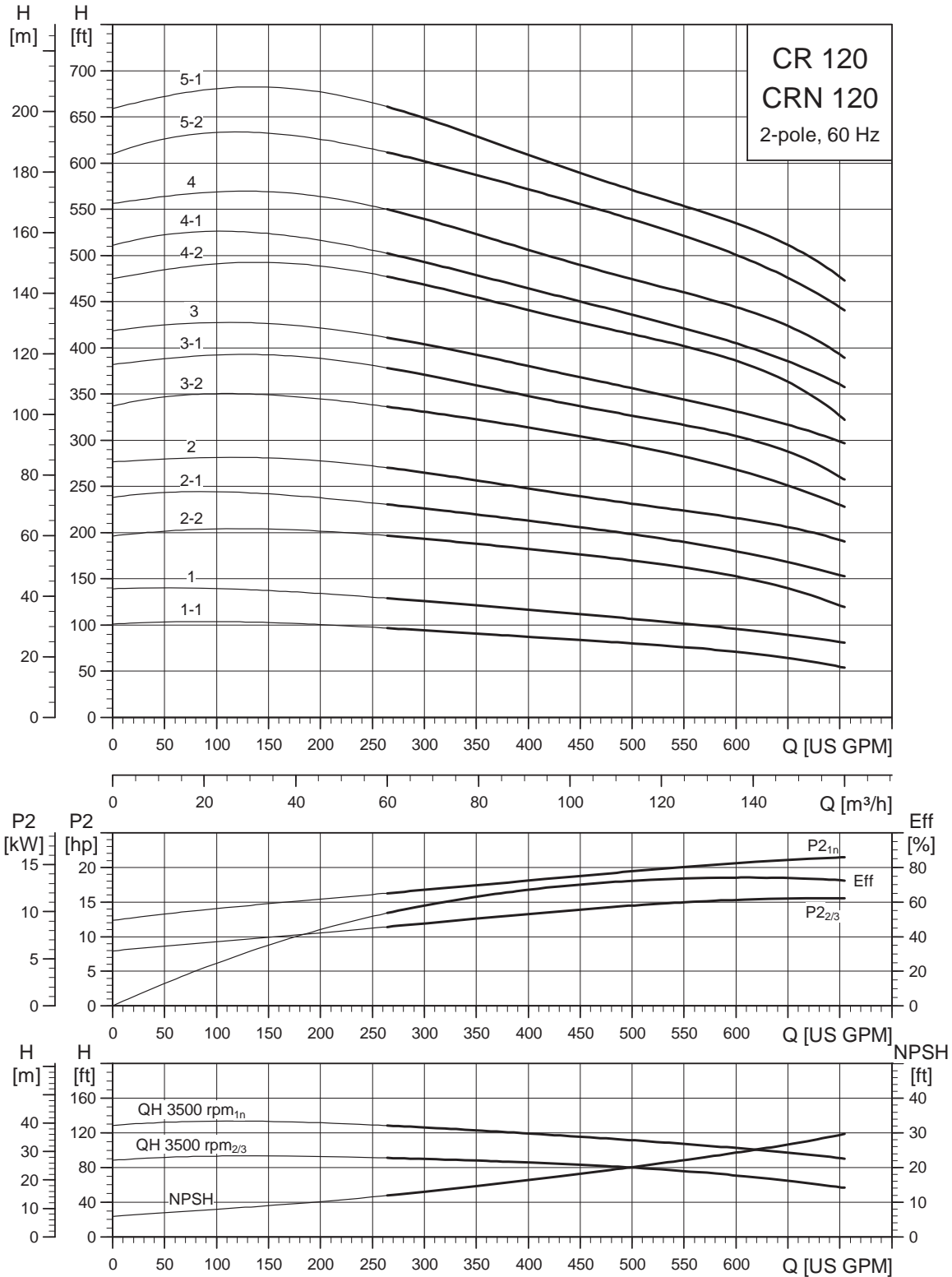

TM03 9192 0209

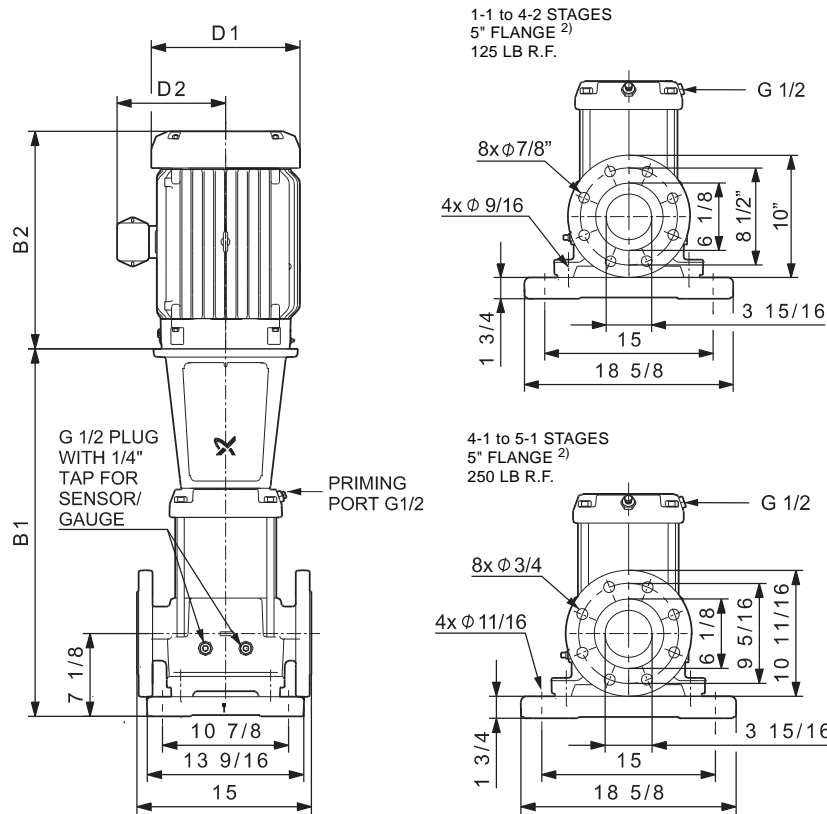

TM04 9630 4810

Pump type	P2 [hp]	Ph.	Dimensions [inch]									Ship Wt. [lbs.]	Dimensions [inch]				Ship Wt. [lbs.]
			B1	TEFC			ODP			MLE							
				D1	D2	B1+B2	D1	D2	B1+B2	D1	D2		B1+B2				
CR(E) 120-1-1	20	3	32.83	10.22	8.67	49.41	11.50	8.92	52.52	427	13.39	12.13	51.61	534			
CR(E) 120-1	25	3	32.83	12.94	11.52	52.65	11.50	8.94	53.64	507	13.39	12.13	55.55	561			
CR 120-2-2	40	3	38.98	15.32	13.11	62.17	13.25	12.21	62.23	704	-	-	-	-			
CR 120-2-1	40	3	38.98	15.32	13.11	62.17	13.25	12.21	62.23	704	-	-	-	-			
CR 120-2	50	3	38.98	16.88	14.12	66.79	13.25	12.21	61.73	735	-	-	-	-			
CR 120-3-2	60	3	45.08	19.00	14.90	75.87	15.12	13.19	71.21	936	-	-	-	-			
CR 120-3-1	60	3	45.08	19.00	14.90	75.87	15.12	13.19	71.21	936	-	-	-	-			
CR 120-3	75	3	45.08	19.00	14.90	75.87	15.18	13.19	71.21	1045	-	-	-	-			
CR 120-4-2	75	3	51.69	19.00	14.90	82.48	15.18	13.19	77.82	1199	-	-	-	-			
CR 120-4-1	100	3	51.69	19.00	17.38	82.51	15.12	13.19	79.07	1468	-	-	-	-			
CR 120-4	100	3	51.69	19.00	17.38	82.51	15.12	13.19	79.07	1468	-	-	-	-			
CR 120-5-2	100	3	57.80	19.00	17.38	88.62	15.12	13.19	85.18	1490	-	-	-	-			

<sup>1)</sup> Weights are based on pump with TEFC motor (see price list for individual weights).

<sup>2)</sup> CR 5" flange is not manufactured to ANSI specification. Gasket contact surface is approximately 0.25". CR 6" ANSI flange adapter is manufactured to ANSI B16.5 specification.

All dimensions in inches unless otherwise noted.

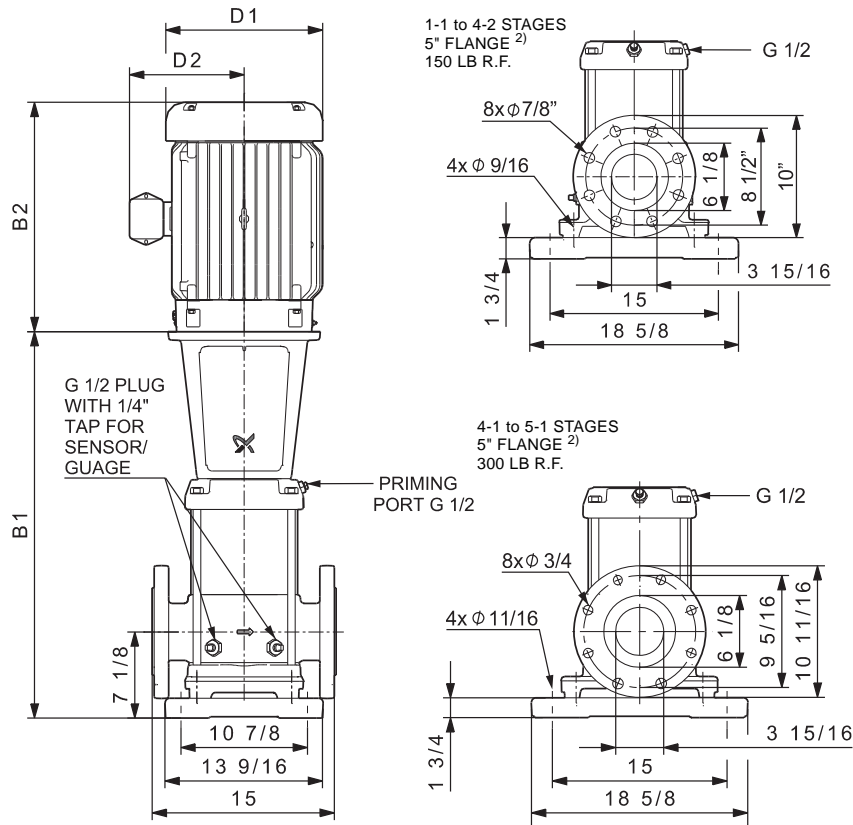

TM04 9631 4810

Pump type	P2 [hp]	Ph.	Dimensions [inch]									Dimensions [inch]			
			B1	TEFC			ODP			Ship Wt. [lbs.]	MLE			Ship Wt. [lbs.]	
				D1	D2	B1+B2	D1	D2	B1+B2		D1	D2	B1+B2		
CRN(E) 120-1-1	20	3	32.83	10.22	8.67	49.41	11.50	8.92	52.52	434	13.39	12.13	51.61	541	
CRN(E) 120-1	25	3	32.83	12.94	11.52	52.65	11.50	8.94	53.64	514	13.39	12.13	55.55	568	
CRN 120-2-2	40	3	38.98	15.32	13.11	62.17	13.25	12.21	62.23	711	-	-	-	-	
CRN 120-2-1	40	3	38.98	15.32	13.11	62.17	13.25	12.21	62.23	711	-	-	-	-	
CRN 120-2	50	3	38.98	16.88	14.12	66.79	13.25	12.21	61.73	742	-	-	-	-	
CRN 120-3-2	60	3	45.08	19.00	14.90	75.87	15.12	13.19	71.21	943	-	-	-	-	
CRN 120-3-1	60	3	45.08	19.00	14.90	75.87	15.12	13.19	71.21	943	-	-	-	-	
CRN 120-3	75	3	45.08	19.00	14.90	75.87	15.18	13.19	71.21	1052	-	-	-	-	
CRN 120-4-2	75	3	51.69	19.00	14.90	82.48	15.18	13.19	77.82	1206	-	-	-	-	
CRN 120-4-1	100	3	51.69	19.00	17.38	82.51	15.12	13.19	79.07	1475	-	-	-	-	
CRN 120-4	100	3	51.69	19.00	17.38	82.51	15.12	13.19	79.07	1475	-	-	-	-	
CRN 120-5-2	100	3	57.8	19.00	17.38	88.62	15.12	13.19	85.18	1497	-	-	-	-	

<sup>1)</sup> Weights are based on pump with TEFC motor (see price list for individual weights).

<sup>2)</sup> CR 5" flange is not manufactured to ANSI specification. Gasket contact surface is approximately 0.25". CR 6" ANSI flange adapter is manufactured to ANSI B16.5 specification.

All dimensions in inches unless otherwise noted.



## CR, CRN 150

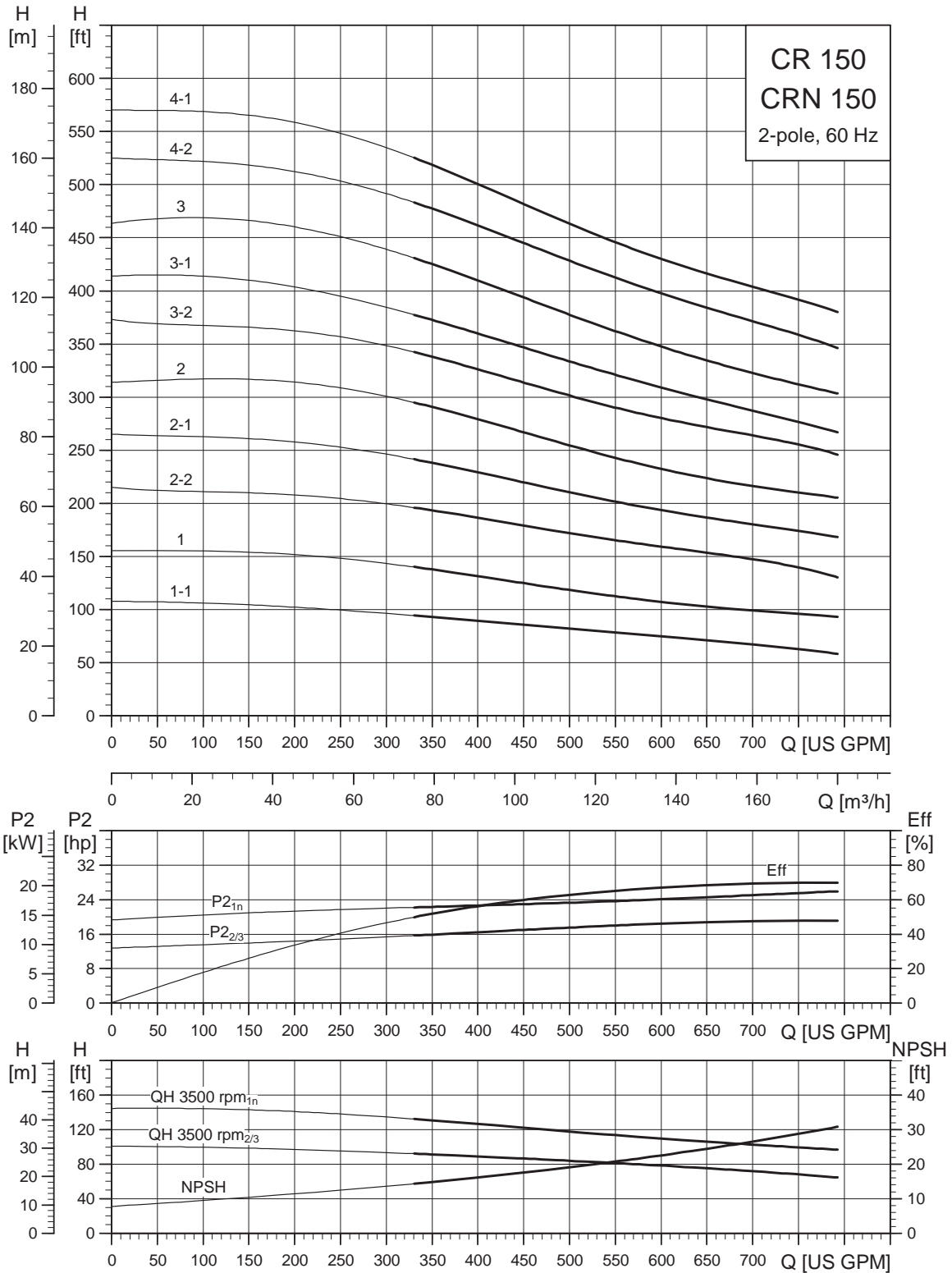

TM03 9193 0209

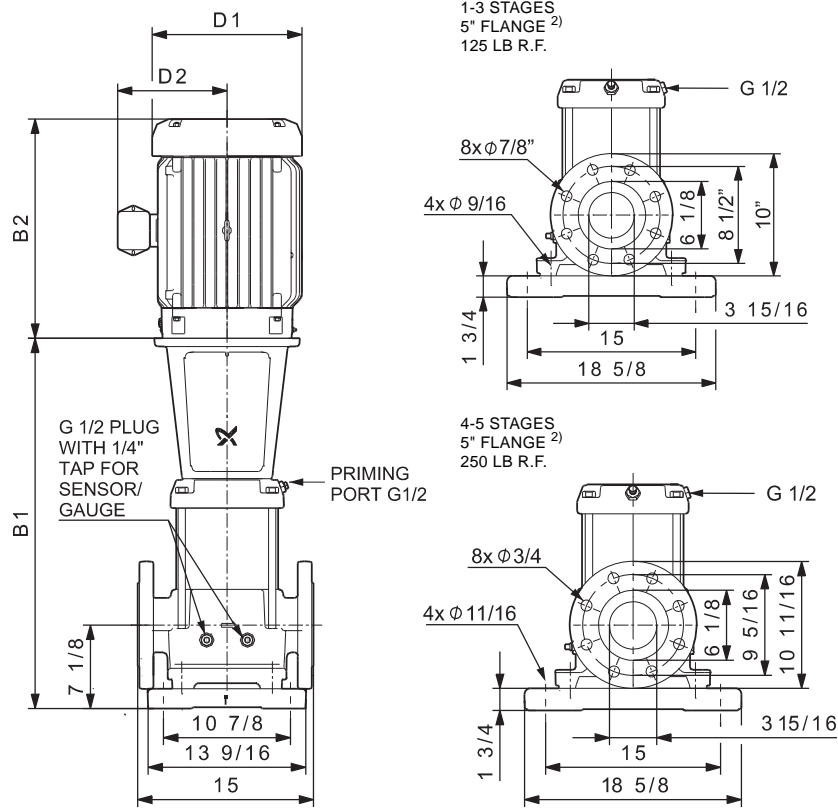

Pump type	P2 [hp]	Ph.	Dimensions [inch]									Dimensions [inch]			
			B1	TEFC			ODP			Ship Wt. <sup>1)</sup> [lbs.]	MLE			Ship Wt. [lbs.]	
				D1	D2	B1+B2	D1	D2	B1+B2		D1	D2	B1+B2		
CR(E) 150-1-1	25	3	32.83	12.94	11.52	52.65	11.50	8.94	53.64	507	13.39	12.13	55.55	561	
CR(E) 150-1	30	3	32.83	15.32	13.11	56.02	11.50	8.94	54.64	669	13.39	12.13	55.55	587	
CR 150-2-2	40	3	38.98	15.32	13.11	62.17	13.25	12.21	62.23	705	-	-	-	-	
CR 150-2-1	50	3	38.98	16.88	14.12	66.79	13.25	12.21	61.73	735	-	-	-	-	
CR 150-2	60	3	38.98	19.00	14.90	69.77	15.12	13.19	65.11	915	-	-	-	-	
CR 150-3-2	75	3	45.55	19.00	14.90	76.34	15.18	13.19	71.68	1178	-	-	-	-	
CR 150-3-1	75	3	45.55	19.00	14.90	76.34	15.18	13.19	71.68	1178	-	-	-	-	
CR 150-3	100	3	45.55	19.00	17.38	76.37	15.12	13.19	72.93	1215	-	-	-	-	
CR 150-4-2	100	3	51.69	19.00	17.38	82.51	15.12	13.19	79.07	1234	-	-	-	-	
CR 150-4-1	100	3	51.69	19.00	17.38	82.51	15.12	13.19	79.07	1234	-	-	-	-	

<sup>1)</sup> Weights are based on pump with TEFC motor (see price list for individual weights).

<sup>2)</sup> CR 5" flange is not manufactured to ANSI specification. Gasket contact surface is approximately 0.25". CR 6" ANSI flange adapter is manufactured to ANSI B16.5 specification.

All dimensions in inches unless otherwise noted.

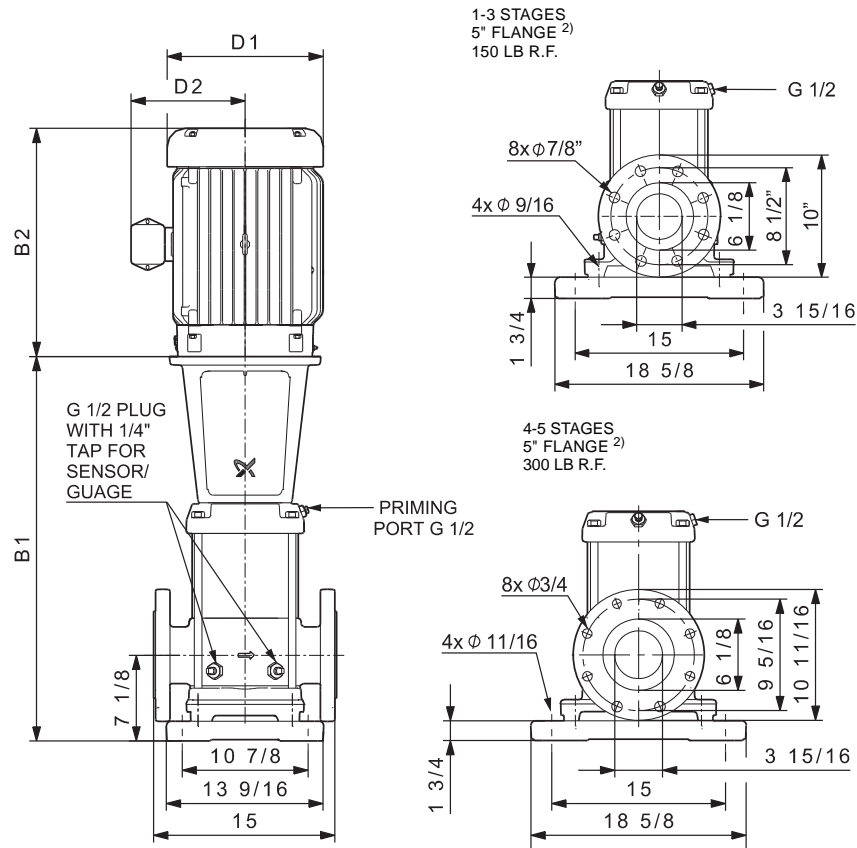

TM04 9633 4810

Pump type	P2 [hp]	Ph.	Dimensions [inch]									Ship Wt. [lbs.]		
			B1	TEFC			ODP			Ship Wt. [lbs.]				
				D1	D2	B1+B2	D1	D2	B1+B2					
CRN(E) 150-1-1	25	3	32.83	12.94	11.52	52.65	11.50	8.94	53.64	514	13.39	12.13	55.55	568
CRN(E) 150-1	30	3	32.83	15.32	13.11	56.02	11.50	8.94	54.64	675	13.39	12.13	55.55	594
CRN 150-2-2	40	3	38.98	15.32	13.11	62.17	13.25	12.21	62.23	711	-	-	-	-
CRN 150-2-1	50	3	38.98	16.88	14.12	66.79	13.25	12.21	61.73	741	-	-	-	-
CRN 150-2	60	3	38.98	19.00	14.90	69.77	15.12	13.19	65.11	922	-	-	-	-
CRN 150-3-2	75	3	45.55	19.00	14.90	76.34	15.18	13.19	71.68	1184	-	-	-	-
CRN 150-3-1	75	3	45.55	19.00	14.90	76.34	15.18	13.19	71.68	1184	-	-	-	-
CRN 150-3	100	3	45.55	19.00	17.38	76.37	15.12	27.38	72.93	1222	-	-	-	-
CRN 150-4-2	100	3	51.69	19.00	17.38	82.51	15.12	27.38	79.07	1243	-	-	-	-
CRN 150-4-1	100	3	51.69	19.00	17.38	82.51	15.12	27.38	79.07	1243	-	-	-	-

<sup>1)</sup> Weights are based on pump with TEFC motor (see price list for individual weights).

<sup>2)</sup> CR 5" flange is not manufactured to ANSI specification. Gasket contact surface is approximately 0.25". CR 6" ANSI flange adapter is manufactured to ANSI B16.5 specification.

All dimensions in inches unless otherwise noted.

## Standard motors in the CR range

Motors used in the CR pump range are:

- Grundfos ML or MLE motors
- Grundfos specified Baldor® motors

The information in the tables below applies to following motors type and size:

Type	Phase	Motor range [HP]	Cooling method
ML	3	1/3 - 10	TEFC
	1	1/3 - 10	TEFC
Baldor	3	15 - 100	TEFC
	3	15 - 100	ODP
MLE	1	1/2 - 1 1/2	TEFC
	3	1 - 10	TEFC

Grundfos CR pumps are supplied with heavy-duty 2-pole, NEMA energy efficient C-frame motors built or selected to our rigid specifications. All CR pump motors have heavy-duty bearings for maximum thrust requirements.

## TEFC motors

(Totally Enclosed Fan Cooled, constant speed)

HP	PH	Frame	S.F.	Voltage [V]	Mtr. Eff. [%]	Insul. class	KVA code	Full load current [A]	Service Factor current [A]	Start current [A]	Motor type
1/3	1	56C	1.35	115/230	55	B	K	6.0/3.0	7.6/3.8	28/14	Baldor
	3	56C	1.35	208-230/460	78.5	F	L	1.12-1.1/0.55	1.5-1.45/0.75	7.1-7.7/3.9	ML
1/2	1	56C	1.6	115/230	62	B	K	7.4/3.7	9.8/4.9	39/19.5	Baldor
	3	56C	1.25	208-230/460	78.5	F	K	1.64-1.55/0.78	2.0-1.9/0.95	9.7-10.1/5.1	ML
3/4	1	56C	1.25	115/230	66	B	K	9.6/4.8	11.4/5.7	56/28	Baldor
	3	56C	1.25	208-230/460	79	F	K	2.4-2.3/1.2	2.9-2.75/1.4	14.2-15/7.8	ML
1	1	56C	1.25	115/230	66	B	K	12/6.0	14.4/7.2	77/38.5	Baldor
	3	56C	1.25	208-230/460	80	F	J	3.25-3.35/1.68	4.0-3.9/1.95	19.2-21.8/10.9	ML
1 1/2	1	56C	1.3	115/208-230	71	B	K	17/9.5-8.6	20.4/11.3-10.2	106/58.6-53	Baldor
	3	56C	1.15	208-230/460	84	F	M	4.7-4.6/2.3	5.2-5.1/2.55	33.8-36.8/18.4	ML
2	1	56C	1.15	115/208-230	74	F	K	23/12.7-11.5	25.4/14.0-12.7	156/86-78	Baldor
	3	56C	1.15	208-230/460	85.5	F	G	5.7-5.4/2.7	6.55-6.1/3.05	46.2-48.6/24.3	ML
3	1	182TC	1.15	115/208-230	75	F	H	29/16-14.5	31.8/18-15.9	170/94-85	Baldor
	3	182TC	1.15	208-230/460	86.5	F	M	8.4-7.7/3.9	9.5-8.6/4.3	79.0-80.1/40.6	ML
5	1	213TCZ	1.15	208-230	80	F	J	24-22	27-25	188-170	Baldor
	3	182TC	1.15	208-230/460	88.5	F	L	13.8-13.0/6.5	15.6-14.6/7.3	124-129/64.4	ML
7 1/2	1	213TC	1.15	208-230	82	F	F	33.8-31	38.5-35.5	244-220	Baldor
	3	213TC	1.15	208-230/460	90	F	N	20.4-19.4/9.7	23-21.5/10.8	192-202/101	ML
10	1	213TC	1.15	230	85.5	F	F	40	46	284	Baldor
	3	213TC	1.15	208-230/460	90.2	F	L	26.5-25.5/12.8	30.5-28.5/14.5	239-252/127	ML
15	3	254TCZ	1.15	208-230/460	90.2	F	K	37.5-34/17	42.5-39/19.5	270-304/152	Baldor
20	3	254TCZ	1.15	208-230/460	90.2	F	K	47-46/23	53-52/26	355-412/206	Baldor
25	3	284TSCZ	1.15	230/460	91	F	J	56/28	64/32	498/249	Baldor
30	3	286TSCZ	1.15	230/460	91	F	G	70/35	78/39	450/225	Baldor
40	3	286TSC	1.15	230/460	91.7	F	G	88/44	102/51	614/307	Baldor
50	3	326TSCZ	1.15	230/460	93	F	G	110/55	128/64	746/393	Baldor
60	3	364TSCZ	1.15	230/460	93	F	G	134/67	154/77	918/459	Baldor
75	3	365TSCZ	1.15	230/460	93	F	G	166/83	188/94	1162/581	Baldor
100	3	405TSCZ	1.15	230/460	93.6	F	G	216/108	246/123	1422/711	Baldor

**It is not recommended that an off-the-shelf standard Baldor motor be used on a Grundfos pump. Ideally, the best motor choice would be the Grundfos specified motor.**

Single-phase Grundfos specified motors up to 7.5 hp have a built-in thermal overload switch.

Other motor types are available (i.e., Explosion proof, Mill and Chem duty, Premium Efficiency, etc.); consult local Grundfos company for more information.

Pumps supplied by Grundfos Canada are normally supplied with motors from other manufactures. 575 volt motors meet NEMA energy efficient standards. Dimensions and data will vary, contact local Grundfos company for more information.

All values are subject to change without notice.

Baldor motor



TM02 7696 3803

ML motor



GR 7845

## ODP motors

(Open Drip Proof, constant speed)

HP	PH	ODP Frame	ODP S.F.	ODP Voltage	ODP Mtr. Eff. %	ODP Insul. class	ODP KVA code	ODP Full load current	ODP service Factor current	ODP Start current
15	3	254TCZ	1.15	208-230/460	89.5	F	H	37-35/17.5	40-39.4/19.7	225-248/124
20	3	254TC	1.15	230/460	90.2	B	G	48/24	55/27.5	306/153
25	3	284TSCZ	1.15	208-230/460	91	B	G	64-59/29.5	74-67/33.5	335-374/187
30	3	284TSC	1.15	230/460	91	F	H	70/35	80/40	480/240
40	3	286TSCZ	1.15	230/460	91.7	F	F	94/47	108/54	542/271
50	3	324TSCZ	1.15	230/460	92.4	F	G	116/58	134/67	732/366
60	3	324TSCZ	1.15	230/460	93	B	G	132/66	152/76	876/438
75	3	364TSCZ	1.15	230/460	93	F	G	168/84	192/96	1110/555
100	3	365TSCZ	1.15	230/460	93	F	G	226/113	260/130	1380/690

Baldor motor



TM02 7696

## 2 Pole MLE motors

(Integrated variable frequency drive)

Hp	Short type designation	Voltage [V]	Ph	NEMA frame Size	Service Factor	Motor full load efficiency [%]	Full load current amps ** [A]	Service factor current amps [A]	Power factor	Full load speed [rpm]	Sound pressure level dB(A)
1/2	MLE71AB-2-56C-C	208-230	1	56C	1.0	71.0*	2.8 - 2.5	-	0.96	3400	63
3/4	MLE71BA-2-56C-C	208-230	1	56C	1.0	74.0*	3.9 - 3.5	-	0.97	3400	63
1	MLE80AA-2-56C-C	208-230	1	56C	1.0	76.0*	5.2 - 4.7	-	0.97	3400	62
1	MLE90CC-2-56C-G	460-480	3	56C	1.25	77.0	1.7	2.10	0.73	3500	65
1 1/2	MLE80BA-2-56C-C	208-230	1	56C	1.0	77.0*	7.5 - 6.8	-	0.97	3400	63
1 1/2	MLE90CC-2-56C-G	208-230	3	56C	1.0	82.5	4.35 - 4.05	-	0.94	3480	65
1 1/2	MLE90CC-2-56C-G	460-480	3	56C	1.15	84.0	2.2	2.50	0.83	3480	65
2	MLE90CC-2-56C-G	208-230	3	56C	1.0	84.0	5.75 - 5.25	-	0.95	3460	70
2	MLE90CC-2-56C-G	460-480	3	56C	1.15	85.5	2.7	3.10	0.87	3460	70
3	MLE90FA-2-182TC-G	208-230	3	182TC	1.0	85.5	8.3 - 7.6	-	0.95	3460	70
3	MLE90FA-2-182TC-G	460-480	3	182TC	1.15	86.5	3.7	4.30	0.91	3460	70
5	MLE112CA-2-184TC-G	208-230	3	184TC	1.0	87.5	13.8 - 13.3	-	0.94	3470	75
5	MLE112CA-2-184TC-G	460-480	3	184TC	1.15	88.5	6.1	7.00	0.92	3470	75
7 1/2	MLE132DA-2-215TC-G	208-230	3	215TC	1.0	88.5	20.0 - 18.5	-	0.94	3450	80
7 1/2	MLE132DA-2-215TC-G	460-480	3	215TC	1.15	88.5	8.9	10.3	0.94	3470	80
10	MLE132FA-2-215TC-G	460-480	3	215TC	1.15	89.5	11.6	13.4	0.93	3500	80
15	MLE160AA-2- 254TC-F	460-480	3	254TC	1.15	90.2	18.0	20.6	0.89	3500	68
20	MLE160AB-2- 256TC-F	460-480	3	256TC	1.15	90.2	24.0	27.5	0.89	3540	68
25	MLE160AC-2- 284TC-F	460-480	3	284TC	1.15	91.0	30.5	35.0	0.88	3540	70
30	MLE180AA-2- 286TC-F	460-480	3	286TC	1.15	91.0	36.5	42.0	0.88	3540	70

## Pumped liquids

Thin, non-explosive liquids, not containing solid particles or fibers. The liquid must not chemically attack the pump materials. When pumping liquids with a density and/or viscosity higher than that of water, oversized motors must be used, if required.

Whether a pump is suitable for a particular liquid depends on a number of factors of which the most important are the chloride content, pH value, temperature and content of chemicals, oils, etc.

Please note that aggressive liquids (e.g. sea water and some acids) may attack or dissolve the protective oxide film of the stainless steel and thus cause corrosion. The CR(E), CRI(E), CRN(E) pump types are suitable for the following liquids:

### CR(E), CRI(E)

- Non-corrosive liquids.

For liquid transfer, circulation and pressure boosting of cold or hot clean water.

### CRN(E)

- Industrial liquids.

In systems where all parts in contact with the liquid must be made of high-grade stainless steel.

### CRT(E)

- Saline liquids.
- Hypochlorites.
- Acids.

For saline or chloride-containing liquids such as sea water or oxidizing agents such as hypochlorites, CRT(E) pumps of titanium are available. See separate product guide on CRT(E).

## List of pumped liquids

A number of typical liquids are listed on the following pages.

Other pump versions may be applicable, but those stated in the list are considered to be the best choices. The table is intended as a general guide only, and cannot replace actual testing of the pumped liquids and pump materials under specific working conditions.

The list should, however, be applied with some caution as factors such as

- concentration of the pumped liquid,
- liquid temperature or
- pressure

may affect the chemical resistance of a specific pump version.

Safety precautions must be made when pumping dangerous liquids.

### Notes

<b>D</b>	Often with additives.
<b>E</b>	Density and/or viscosity differ from that of water. Allow for this when calculating motor output and pump performance.
<b>F</b>	Pump selection depends on many factors. Contact Grundfos.
<b>H</b>	Risk of crystallization/precipitation in shaft seal
<b>1</b>	The pumped liquid highly inflammable.
<b>2</b>	The pumped liquid is combustible.
<b>3</b>	Insoluble in water.
<b>4</b>	Low self-ignition point.

# Pumped liquids

CR, CRI, CRN, CRE, CRIE, CRNE

Pumped liquid	Note	Liquid concentration, liquid temperature	CR		CRN	
			1s, 1, 3, 5, 10, 15, 20	32, 45, 64, 90, 120, 150	1s, 1, 3, 5, 10, 15, 20	32, 45, 64, 90, 120, 150
Acetic acid CH <sub>3</sub> COOH		5 %, 68 °F			HQQE	HQQE/HBQE
Acetone CH <sub>3</sub> COCH <sub>3</sub>	1, F	100 %, 68 °F			HBQE	KUBE/HBQE
Alkaline degreasing agent	D, F		HQQE	KUHE/HBQE		
Ammonium bicarbonate NH <sub>4</sub> HCO <sub>3</sub>	E	20 %, 86 °F			HQQE	KUHE/HBQE
Ammonium hydroxide NH <sub>4</sub> OH		20 %, 104 °F	HQQE	KUBE/HBQE		
Aviation fuel	1, 3, 4, F	100 %, 68 °F	HQBv	KUBV/HBQV		
Benzoic acid C <sub>6</sub> H <sub>5</sub> COOH	H	0,5 %, 68 °F			HQQV	KUBV/HBQV
Boiler water		<248 °F	HQQE	KUBE/HBQE		
	F	248 °F - 356 °F	-	-		
Calcareous water		< 194 °F	HQQE	KUHE		
Calcium acetate (as coolant with inhibitor) Ca(CH <sub>3</sub> COO) <sub>2</sub>	D, E	30 %, 122 °F	HQQE	KUHE		
Calcium hydroxide Ca(OH) <sub>2</sub>	E	Saturated solution, 122 °F	HQQE	KUHE		
Chloride-containing water	F	< 86 °F, max. 500 ppm			HQQE	KUHE
Chromic acid H <sub>2</sub> CrO <sub>4</sub>	H	1 %, 68 °F			HQQV	HQQV/HBQV
Citric acid HOC(CH <sub>2</sub> CO <sub>2</sub> H) <sub>2</sub> COOH	H	5 %, 104 °F			HQQE	KUHE/HBQE
Completely desalinated water (demineralized water)		< 248 °F			HQQE	KUBE/HBQE
Condensate		< 194 °F	HQQE	KUHE/HBQE		
Copper sulfate CuSO <sub>4</sub>	E	10 %, 122 °F			HQQE	KUHE
Corn oil	D, E, 3	100 %, 176 °F	HQQV	KUHV/HBQV		
Diesel oil	2, 3, 4, F	100 %, 68 °F	HQBv	KUBV/HBQV		
Domestic hot water (potable water)		< 248 °F	HQQE	KUBE/HBQE		
Ethanol (ethyl alcohol) C <sub>2</sub> H <sub>5</sub> OH	1, F	100 %, 68 °F	HQQE	KUBE/HBQE		
Ethylene glycol HOCH <sub>2</sub> CH <sub>2</sub> OH	D, E	50 %, 122 °F	HQQE	KUHE		
Formic acid HCOOH		5 %, 68 °F			HQQE	KUBE/HBQE
Glycerine (glycerol) OHCH <sub>2</sub> CH(OH)CH <sub>2</sub> OH	D, E	50 %, 122 °F	HQQE	KUHE/HBQE		
Hydraulic oil (mineral)	E, 2, 3	100 %, 212 °F	HQQV	KUBV/HBQE		
Hydraulic oil (synthetic)	E, 2, 3	100 %, 212 °F	HQQV	KUBV/HBQE		
Isopropyl alcohol CH <sub>3</sub> CHOHCH <sub>3</sub>	1, F	100 %, 68 °F	HQBv	KUBV/HBQV		
Lactic acid CH <sub>3</sub> CH(OH)COOH	E, H	10 %, 68 °F			HQQE	KUBE/HBQE
Linoleic acid C <sub>17</sub> H <sub>31</sub> COOH	E, 3	100 %, 68 °F	HQQV	KUBV/HBQV		
Methanol (methyl alcohol) CH <sub>3</sub> OH	1, F	100 %, 68 °F	HQQE	KUBE/HBQE		
Motor oil	E, 2, 3	100 %, 176 °F	HQQV	KUBV/HBQV		
Naphthalene C <sub>10</sub> H <sub>8</sub>	E, H	100 %, 176 °F	HQQV	KUHV/HBQV		
Nitric acid HNO <sub>3</sub>	F	1 %, 68 °F			HQQE	HQQE/HBQE
Oil-containing water		< 212 °F	HQQV	KUBV/HBQV		
Olive oil	D, E, 3	100 %, 176 °F	HQQV	KUHV/HBQV		

# Pumped liquids

CR, CRI, CRN, CRE, CRIE, CRNE

Pumped liquid	Note	Liquid concentration, liquid temperature	CR		CRN	
			1s, 1, 3, 5, 10, 15, 20	32, 45, 64, 90, 120, 150	1s, 1, 3, 5, 10, 15, 20	32, 45, 64, 90, 120, 150
Oxalic acid (COOH) <sub>2</sub>	H	1 %, 68 °F			HQQE	KUBE/HBQE
Ozone-containing water (O <sub>3</sub> )		1 PPM, < 105 °F			HQQE	KUBE/HBQE
Peanut oil	D, E, 3	100 %, 194 °F	HQQV	KUHV/ HBQV		
Petrol/gasoline	1, 3, 4, F	100 %, 68 °F	HQBV	KUBV/HBQV		
Phosphoric acid H <sub>3</sub> PO <sub>4</sub>	E	20 %, 68 °F			HQQV	KUBV/HBQV
Propanol C <sub>3</sub> H <sub>7</sub> OH	1, F	100 %, 68 °F	HQQV	KUBV/HBQV		
Propylene glycol CH <sub>3</sub> CH(OH)CH <sub>2</sub> OH	D, E	50 %, 194 °F	HQQE	KUHE		
Potassium carbonate K <sub>2</sub> CO <sub>3</sub>	E	20 %, 122 °F	HQQE	KUHE		
Potassium formate (as coolant with inhibitor) KOOCH	D, E	30 %, 122 °F	HQQE	KUHE		
Potassium hydroxide KOH	E	20 %, 122 °F			HQQE	KUHE
Potassium permanganate KmnO <sub>4</sub>		5 %, 68 °F			HQQE	HQQE/HBQE
Rape seed oil	D, E, 3	100 %, 176 °F	HQQV	KUHV/HBQV		
Salicylic acid C <sub>6</sub> H <sub>4</sub> (OH)COOH	H	0,1 %, 68 °F			HQQE	KUBE/HBQE
Silicone oil	E, 3	100 %	HQQV	KUBV/HBQV		
Sodium bicarbonate NaHCO <sub>3</sub>	E	10 %, 140 °F			HQQE	KUHE/HBQE
Sodium chloride (as coolant) NaCl	D, E	30 %, < 41 °F, pH>8	HQQE	KUHE		
Sodium hydroxide NaOH	E	20 %, 122 °F			HQQE	KUHE
Sodium hypochlorite NaOCl	F	0,1 %, 68 °F			HQQE	HQQE
Sodium nitrate NaNO <sub>3</sub>	E	10 %, 140 °F			HQQE	KUHE/HBQE
Sodium phosphate Na <sub>3</sub> PO <sub>4</sub>	E, H	10 %, 140 °F			HQQE	KUHE
Sodium sulfate Na <sub>2</sub> SO <sub>4</sub>	E, H	10 %, 140 °F			HQQE	KUHE/HBQE
Softened water		< 248 °F			HQQE	KUBE/HBQE
Soybean oil	D, E, 3	100 %, 176 °F	HQQV	KUHV/HBQV		
Sulfuric acid H <sub>2</sub> SO <sub>4</sub>	F	1 %, 68 °F			HQQV	KUHV/KBQV
Sulfurous acid H <sub>2</sub> SO <sub>3</sub>		1 %, 68 °F			HQQE	KUBE/HBQE
Swimming pool water (low chloride)		Max 5 ppm free chlorine (Cl <sub>2</sub> )	HQQE	KUBE/HBQE		



## Pipework connection

For pipework connection, various sets of counter flanges and couplings are available.

### Adapter kit

6" flanges are available for CR, CRN 120 and 150 pumps. To use 6" flanges, two adapter kits must be ordered per pump.

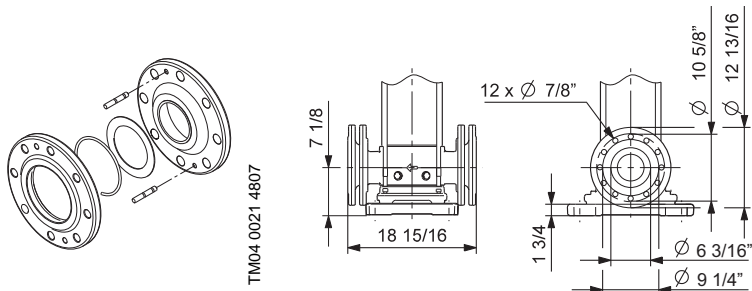
Adapter kit	Pump type	Pipe connection	Number of flange kits needed	Product number
 <p>TM04 0021 4807</p>	CR 120 CR 150	6" RF 250 lb. Ductile iron	2	96638184
	CRN 120 CRN 150	6" RF 300 lb. ANSI 316 SS	2	96638186

### Counter flanges for CR(E)

A set consists of two counter flanges, two gaskets, bolts and nuts.

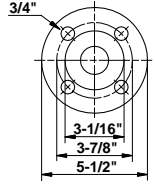
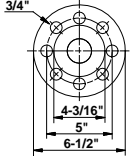
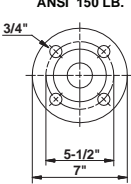
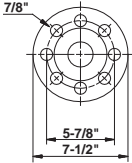
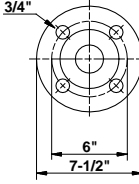
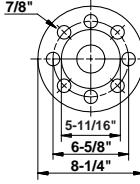
Counter flange	Pump type	Description	Pressure class	Pipework connection	Product number
	TM02 5691 3802	CR 1s CR(E) 1 CR(E) 3 CR(E) 5	Threaded	ANSI 250 lb.	1 1/4" NPT 91122260
	TM02 5692 3802	CR(E) 10 CR(E) 15 CR(E) 20	Threaded	ANSI 250 lb.	2" NPT 335021
 <p>ANSI 150 LB.</p>	TM02 5693 + 5694 3802	CR(E) 32	Threaded	ANSI 125 lb.	2 1/2" NPT 559601
 <p>ANSI 300 LB.</p>			Threaded	ANSI 250 lb.	2 1/2" NPT 345050
	TM02 5695 + 5696 3802	CR(E) 45	Threaded	ANSI 125 lb.	3" NPT 569601
			Threaded	ANSI 250 lb.	3" NPT 91121952

Counter flange	Pump type	Description	Pressure class	Pipework connection	Product number	
	TM02 5697 + 5698 3802	CR(E) 64 CR(E) 90	Threaded	ANSI 125 lb.	4" NPT	579801
			Threaded	ANSI 250 lb.	4" NPT	3600028
	TM02 5697 + 5698 3802	CR(E) 120 CR(E) 150	Threaded	ANSI 125 lb.	5" NPT	91121956
			Threaded	ANSI 250 lb.	5" NPT	91121957

### Counter flanges for CRN(E)

Counterflanges for CRN(E) pumps are made of stainless steel according to AISI 316.

A set consists of two counter flanges, two gaskets, bolts and nuts.

Counter flange	Pump type	Description	Pressure class	Pipework connection	Product number	
	TM02 5691 3802	CRI(E), CRN(E) 1s, 1, 3 and 5	Threaded	ANSI 300 lb.	1 1/4" NPT	91129013
	TM02 5692 3802	CRI(E), CRN(E) 10, 15, 20	Threaded	ANSI 300 lb.	2" NPT	339919
	TM02 5693 + 5694 3802	CRN(E) 32	Threaded	ANSI 150 lb.	2 1/2" NPT	91121951
			Threaded	ANSI 300 lb.	2 1/2" NPT	0ID00138
	TM02 5695 + 5696 3802	CRN(E) 45	Threaded	ANSI 150 lb.	3" NPT	91121953
			Threaded	ANSI 300 lb.	3" NPT	91121954

# Accessories

CR, CRI, CRN, CRE, CRIE, CRNE

Counter flange	Pump type	Description	Pressure class	Pipework connection	Product number
	<b>CRN(E) 64</b> <b>CRN(E) 90</b>	Threaded	ANSI 150 lb.	4" NPT	01D00148
		Threaded	ANSI 300 lb.	4" NPT	91121955
	<b>CRN(E) 120</b> <b>CRN(E) 150</b>	Threaded	ANSI 150 lb.	5" NPT	91121958
		Threaded	ANSI 300 lb.	5" NPT	91121959

## PJE couplings for CRN(E)

Couplings for CRN(E) pumps are made of stainless steel according to AISI 316.

A set consists of two couplings, two gaskets, two pipe stub and bolts and nuts.

Couplings	Pump type	Pipe stub	Rated pressure	Pipework connection	Rubber parts	Number of coupling sets needed	Product number
	<b>CRI(E),</b> <b>CRN(E)</b> <b>1s, 1, 3 and 5</b>	Threaded	1160 psi	1 1/4" NPT	EPDM	1	4013010
					FKM	1	01D00118
	<b>CRI(E)</b> <b>CRN(E)</b> <b>10, 15 and 20</b>	Threaded	1015 psi	2" NPT	EPDM	1	331301
					FKM	1	01D00128

## FlexiClamp base connections

All sets comprise the necessary number of bolts and nuts as well as a gasket/O-ring.

Base connections	Pump type	Connection	Pipework connection	Rubber parts	Product number
	<b>CRI(E), CRN(E)</b> <b>1s, 1, 3 and 5</b>	Oval (cast iron)	1" NPT	Klingersil	96468491
			1 1/4" NPT	Klingersil	96470781
		Oval (stainless steel)	1" NPT	Klingersil	96480850
			1 1/4" NPT	Klingersil	96480851

# Accessories

CR, CRI, CRN, CRE, CRIE, CRNE

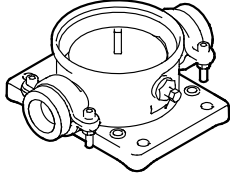
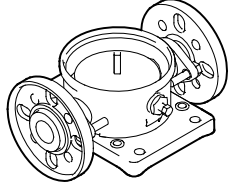
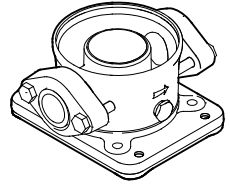
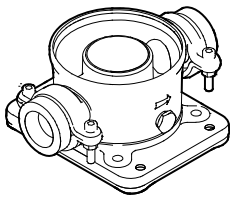
Base connections	Pump type	Connection	Pipework connection	Rubber parts	Product number	
	TM02 1145 0601	CRI(E), CRN(E) 1s, 1, 3 and 5	Union ext. threaded	2" NPT	EPDM	96480852
					FKM	96480853
	TM02 1146 0601	CRI(E), CRN(E) 1s, 1, 3 and 5	ANSI (FGJ) (stainless steel)	1 1/4" NPT	EPDM	96480858
					FKM	96480859
	TM02 1147 0601	CRI(E), CRN(E) 1s, 1, 3 and 5	Clamp, threaded pipe stub	1" NPT	EPDM	96480854
					FKM	96480855
				1 1/4" NPT	EPDM	96480856
					FKM	96480857
	TM02 7237 2803	CRI(E), CRN(E) 10, 15 and 20	Oval (cast iron)	2" NPT	Klingersil	96498838
			Oval (stainless steel)	2" NPT	Klingersil	96498839
	TM02 7238 2803	CRI(E), CRN(E) 10, 15 and 20	ANSI (FGJ) (stainless steel)	2" NPT	EPDM	96511402
					FKM	96511403
	TM02 7239 2803	CRI(E), CRN(E) 10, 15 and 20	Clamp, threaded pipe stub	1 1/2" NPT	EPDM	96500271
					FKM	96500272
				2" NPT	EPDM	96500273
					FKM	96500274
				2" NPT	EPDM	96508602
					FKM	96508603

## Potentiometer for CRE, CRIE, CRNE

Potentiometer for setpoint setting and start/stop of the CRE, CRIE, CRNE pump.

Product	Product number
External potentiometer with cabinet for wall mounting	625468

## G10-LON interface for CRE, CRIE, CRNE

The G10-LON interface is used in connection with data transmission between a Locally Operating Network (LON) and electronically controlled Grundfos pumps applying the Grundfos bus-protocol GENIbus.

Product	Product number
G10-LON interface	00605726

## LiqTec for CR(E), CRI(E) and CRN(E)

A dry-running protection device. The Grundfos LiqTec stops the pump immediately

- if there is no liquid in the pump (dry-running)
- If the liquid temperature exceeds 266 °F ±8 °F.

When connected to the PTC sensors in the motor, the LiqTec also protects the motor against overheating.

LiqTec is prepared for DIN rail mounting in control cabinet.

Enclosure class: IP X0.

## Remote control, R100

R100 is used for wireless communication with the CRE, CRIE, CRNE pump. The communication takes place by means of infrared light.

Product	Product number
R100	96615297

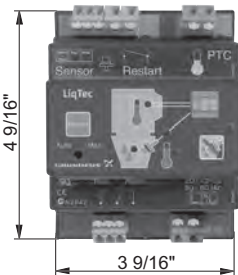
LiqTec dry-running protection	Pump type	Voltage [V]	LiqTec	Sensor ½"	Cable 16.4 ft	Extension cable 49.2 ft	Product number
	TM03 2109 3705 CR(E) CRI(E) CRN(E)	200-240	●	●	●	-	96556429
		80-130	●	●	●	-	96556430
		-	-	-	-	●	96443676

## Sensors for CRE, CRIE, CRNE

Accessory	Measuring range	Product number
Pressure sensor • Connection: 1/4" NPT  Includes a 6 ft cable with removable potted plug in addition to a standard plug for remote mounting.	0-87 psi (0-6 bar)	91136169
	0-145 psi (0-10 bar)	91136170
	0-232 psi (0-16 bar)	91136171
	0-362 psi (0-25 bar)	91136172
	0-580 psi (0-40 bar)	91136173
	0-870 psi (0-60 bar)	91136174

## Gauges for CRE, CRIE, CRNE

Accessory	Measuring range	Product number
Liquid filled pressure gauge • AISI 304/Copper	30" Hg - 30 psi	91123566
	0-60 psi	00ID8562
	0-100 psi	00ID8563
	0-160 psi	00ID8564
	0-200 psi	00ID8565
	0-300 psi	00ID8566
	0-400 psi	00ID8567
	0-600 psi	00ID8568
	30" Hg - 30 psi	91130835
	0-60 psi	00ID8569
Liquid filled pressure gauge • AISI 316	0-100 psi	00ID8570
	0-160 psi	00ID8571
	0-200 psi	00ID8572
	0-300 psi	00ID8573
	0-400 psi	00ID8574
	0-600 psi	00ID8575
	0-200 psi	00ID8576

## Lists of variants - on request

Although the Grundfos CR(E), CRI(E), CRN(E) product range offers a number of pumps for different applications, customers require specific pump solutions to satisfy their needs.

Below please find the range of options available for customizing the CR(E) pumps to meet the customers' demands. Contact Grundfos for further information or for requests other than the ones mentioned below.

## Motors

Variant	Description
<b>Explosion proof motors</b>	For operation in hazardous atmospheres, explosion-proof or dust-ignition-proof motors may be required.
<b>Motors with anti-condensation heating unit</b>	For operation in humid environments motors with built-in anti-condensation heating may be required.
<b>Premium efficient motors</b>	Grundfos offers motors from 1 to 100 Hp with a Premium efficiency class.
<b>Different motor brand</b>	If technically possible, Grundfos can fit the pump with a motor of a brand other than the standard. This will normally increase the time of delivery. Alternatively, the pump can be supplied without a motor (motor thrust rating must be checked).
<b>Oversized motor</b>	Ambient temperatures above 104 °F or installation at altitudes of more than 3280 ft above sea level require the use of an oversized motor (i.e. derating).
<b>4-pole motors</b>	Grundfos offers standard motors fitted with 4-poles.

## Connections and other variants

Variant	Description
<b>Pipe connections</b>	In addition to the wide range of standard flange connections, a 232 Psi DIN standard clamping flange is available. Customized flanges are available according to specifications.
<b>TriClamp connections</b>	TriClamp connections are of a hygienic design with a sanitary coupling for use in the pharmaceutical and food industry.
<b>Electropolished pumps</b>	To substantially reduce the risk of corrosion of the materials. For use in the pharmaceutical/food industry.

## Shaft seals

Variant	Description
<b>Shaft seal with FFKM O-ring material</b>	Shaft seals with FFKM or FXM o-ring material are recommended for applications where the pumped liquid may damage the standard O-ring material.
<b>Seal with flush, quench seal</b>	Recommended for applications involving crystallizing, hardening or sticky liquids.
<b>Cool-Top® shaft seal system</b>	Recommended for applications involving extremely high temperatures. No conventional mechanical shaft seal can withstand liquid temperatures of up to 356 °F for any length of time. For that type of application, Grundfos' unique air-cooled shaft seal system is recommended. In order to ensure a low liquid temperature around the standard shaft seal, the pump is fitted with a special air-cooled shaft seal chamber. No separate cooling is required.
<b>Double shaft seal with pressure chamber</b>	Recommended for applications involving poisonous or explosive liquids. Protects the surrounding environment and the people working in the vicinity of the pump. Consists of two seals mounted in a "back-to-back" arrangement inside a separate pressure seal chamber. As the pressure in the chamber is higher than the pump pressure, leakage is prevented. A dosing pump or a special pressure-intensifier generates the seal chamber pressure.
<b>CRN MAGdrive</b>	Magnetically driven pumps for industrial applications. Key applications are industrial processes involving the handling of aggressive, environmental, dangerous or volatile liquids, e.g. organic compounds, solvents, etc.

## Pumps

Variant	Description
<b>Horizontally mounted pump</b>	For safety or height reasons, certain applications, for instance on ships, require the pump to be mounted in the horizontal position. For easy installation the pump is equipped with brackets that support motor and pump.
<b>Low-temperature pump to -4 °F</b>	Exposed to temperatures down to -40 °F, coolant pumps may require neck-rings with a different diameter in order to prevent impeller drag.
<b>High-speed pump up to 681 psi</b>	For high-pressure applications, a unique pump capable of generating up to 681 psi pressure is available. The pump is equipped with a high-speed motor, type MLE. The direction of rotation is the opposite of that of standard pumps, and the chamber stack is turned upside-down, as a result of which the pumped liquid flows in the opposite direction.
<b>High-pressure pump up to 696 psi</b>	For high-pressure applications, a unique double pump system capable of generating up to 696 psi pressure is available.
<b>Low-NPSH pump (improved suction)</b>	Recommended for boiler-feed applications where cavitation may occur due to poor inlet conditions.
<b>Belt-driven pumps</b>	Belt-driven pumps designed to operate in places with limited space or where no electrical power is available.
<b>Pumps for pharmaceutical and biotechnological applications</b>	CRN(E) pumps designed for applications requiring the sterilization and CIP capability of pipes, valves and pumps. (CIP = Cleaning-In-Place).





CR(E), CRI(E), CRN(E)

**Vertical Multistage Centrifugal Pumps**

**Client Information**

Project title:  
Reference number:  
Client contact:

**Location Information**

For:  
Site:  
Address:

**Application Information**

**Operating Conditions**

	Max.	Norm.	Min.
Capacity (gpm)			
Suction Pressure (psig)			
Discharge Pressure (psig)			
Differential Head (ft)			
Hydraulic Power (hp) at designated capacity			
NPSH Available (ft)			

**Service**

Continuous  
Intermittent (starts/day):

**Pump Information**

Model Information from Type Key and Codes:  
Quantity Required:  
Minimum required flow:

**Product Guide additional information pages**

Materials page number:  
Technical data page number:

**Motor Information**

HP: Phase: Voltage:

**Custom-built pump information (optional):**

Company name:  
Prepared by:  
Phone number: ( )  
Fax number: ( )  
Date: Page 1 of:  
Quote number:

Client name:  
Client number:  
Client phone number: ( )

Unit:  
Service:  
City: State: Zip Code:

**Pumped Fluid**

	Rated	Max.	Norm.
Fluid type:			
Fluid Temperature ( °F) at designated temperature			
Specific Gravity			
Vapor Pressure (psia)			
Viscosity (cp)			
Fluid ph:		Chlorides (ppm):	
Hazardous:		Corrosion/Erosion caused by:	
Flammable:			
Other:			

----> (Example: CR 5-10 A-FGJ-A-E-HQQE )

NPSH required at duty point:

Performance curve page number:

Motor data page number:

Enclosure:

**Additional Information**



## CR(E), CRI(E), CRN(E)

Vertical, non-self-priming, multistage, in-line, centrifugal pump for installation in pipe systems and mounting on a foundation.

The pump has the following characteristics:

- impellers and intermediate chambers are made of AISI \_\_\_\_\_ Stainless steel
- Pump head and base are made of \_\_\_\_\_
- Power transmission is via cast iron split coupling.
- pipework connections is via \_\_\_\_\_

The motor is a \_\_\_\_\_ -phase AC motor.

### Technical

Rated flow: \_\_\_\_\_ GPM  
 Rated head: \_\_\_\_\_ Feet  
 Minimum liquid temperature: \_\_\_\_\_ °F  
 Maximum liquid temperature: \_\_\_\_\_ °F  
 Type of shaft seal: \_\_\_\_\_

### Materials

Material, pump housing: \_\_\_\_\_  
 Material, shaft: AISI \_\_\_\_\_ Stainless Steel  
 Material, impeller: AISI \_\_\_\_\_ Stainless Steel  
 Material, sleeve: AISI \_\_\_\_\_ Stainless Steel  
 Material, seal metal: AISI \_\_\_\_\_ Stainless Steel  
 - seal face: \_\_\_\_\_  
 - seal face: \_\_\_\_\_  
 - seal elastomer: \_\_\_\_\_

### Installation

Maximum ambient temperature: \_\_\_\_\_ °F  
 Max. pressure at stated temp.: \_\_\_\_\_ PSI/ °F  
 Standard, pipe connection: \_\_\_\_\_  
 Size, pipe connection: \_\_\_\_\_  
 Rated pressure, pipe connection: \_\_\_\_\_ PSI  
 Frame size for motor: \_\_\_\_\_ NEMA

### Electrical data

Motor type: \_\_\_\_\_  
 Rated power (P2): \_\_\_\_\_ HP  
 Frequency: \_\_\_\_\_ Hz  
 Rated voltage: \_\_\_\_\_ V  
 Rated current: \_\_\_\_\_ A  
 Service factor: \_\_\_\_\_  
 Starting current: \_\_\_\_\_ A  
 Rated speed: \_\_\_\_\_ RPM  
 Full load motor efficiency: \_\_\_\_\_ %  
 Insulation class: \_\_\_\_\_

### Additional

Gross weight: \_\_\_\_\_ Lbs.  
 Shipping volume: \_\_\_\_\_  
 Model: \_\_\_\_\_



## WebCAPS

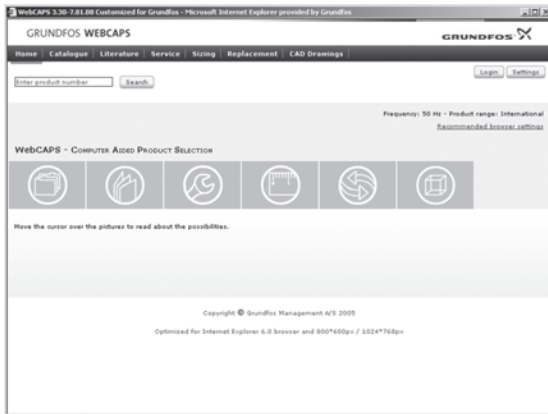

WebCAPS is a **Web-based Computer Aided Product Selection** program available on [www.grundfos.com](http://www.grundfos.com).

WebCAPS contains detailed information on more than 185,000 Grundfos products in more than 22 languages.

In WebCAPS, all information is divided into 6 sections:

- Catalog
- Literature
- Service
- Sizing
- Replacement
- CAD drawings.

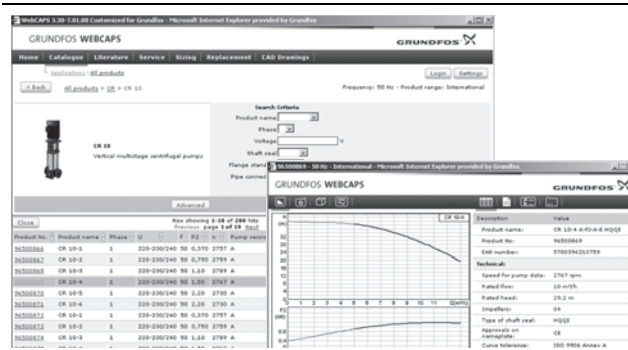

### Catalog

This section is based on fields of application and pump types, and contains

- technical data
- curves (QH, Eta, P1, P2, etc) which can be adapted to the density and viscosity of the pumped liquid and show the number of pumps in operation
- product photos
- dimensional drawings
- wiring diagrams
- quotation texts, etc.

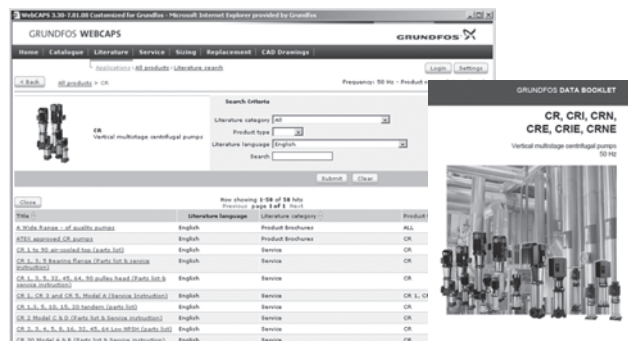

### Literature

In this section you can access all the latest documents of a given pump, such as

- product guides
- installation and operating instructions
- service documentation, such as Service kit catalog and Service kit instructions
- quick guides
- product brochures, etc.

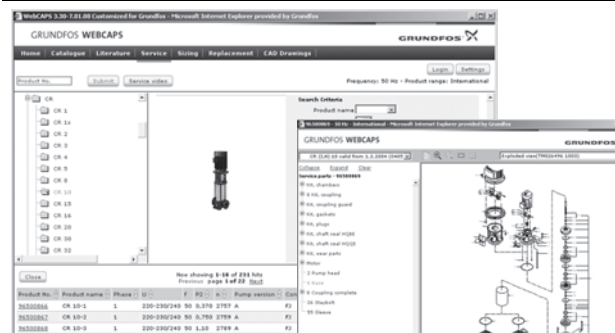

### Service

This section contains an easy-to-use interactive service catalog. Here you can find and identify service parts of both existing and discontinued Grundfos pumps.

Furthermore, this section contains service videos showing you how to replace service parts.

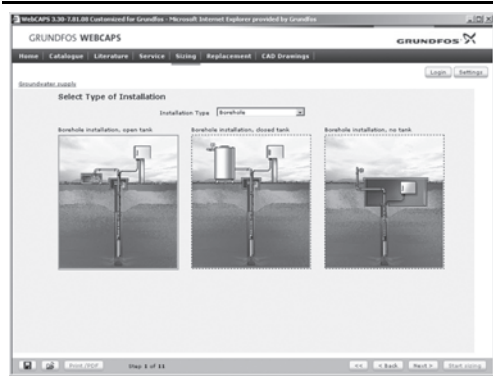

## Sizing

This section is based on different fields of application and installation examples, and gives easy step-by-step instructions in how to

- select the most suitable and efficient pump for your installation
- carry out advanced calculations based on energy consumption, payback periods, load profiles, life cycle costs, etc.
- analyse your selected pump via the built-in life cycle cost tool
- determine the flow velocity in wastewater applications, etc.



## Replacement

In this section you find a guide to selecting and comparing replacement data of an installed pump in order to replace the pump with a more efficient Grundfos pump. The section contains replacement data of a wide range of pumps produced by other manufacturers than Grundfos.

Based on an easy step-by-step guide, you can compare Grundfos pumps with the one you have installed on your site. When you have specified the installed pump, the guide will suggest a number of Grundfos pumps which can improve both comfort and efficiency.



## CAD drawings

In this section it is possible to download 2-dimensional (2D) and 3-dimensional (3D) CAD drawings of most Grundfos pumps.

These formats are available in WebCAPS:

2-dimensional drawings:

- .dxf, wireframe drawings
- .dwg, wireframe drawings.

3-dimensional drawings:

- .dwg, wireframe drawings (without surfaces)
- .stp, solid drawings (with surfaces)
- .eprt, E-drawings.

## WinCAPS



WinCAPS CD-ROM

WinCAPS is a **Windows-based Computer Aided Product Selection** program containing detailed information on more than 185,000 Grundfos products in more than 22 languages.

The program contains the same features and functions as WebCAPS, but is an ideal solution if no Internet connection is available.

WinCAPS is available on CD-ROM and updated once a year



<b>L-CR-PG-001 0212</b>	<b>US</b>
Repl. L-CR-PG-001 12/10	
© 2012 Grundfos Pumps Corp.	

The name Grundfos, the Grundfos logo, and the payoff Be-Think-Innovate are registered trademarks owned by Grundfos Management A/S or Grundfos A/S, Denmark. All rights reserved worldwide.

Subject to alterations.

**GRUNDFOS Pumps Corporation**  
17100 West 118th Terrace  
Olathe, Kansas 66061  
Phone: +1-913-227-3400  
Telefax: +1-913-227-3500

**GRUNDFOS Canada Inc.**  
2941 Brighton Road  
Oakville, Ontario L6H 6C9 Canada  
Phone: +1-905 829 9533  
Telefax: +1-905 829 9512

**Bombas GRUNDFOS de Mexico S.A. de C.V.**  
Boulevard TLC No. 15  
Parque Industrial Stiva Aeropuerto  
Apodaca, N.L. Mexico 66600  
Phone: +52-81-8144 4000  
Telefax: +52-81-8144 4010

[www.grundfos.com](http://www.grundfos.com)

