

Installing, Operating & Maintaining EVO 79 - 599 HIGH EFFICIENCY WATER HEATERS AND HEATING BOILERS

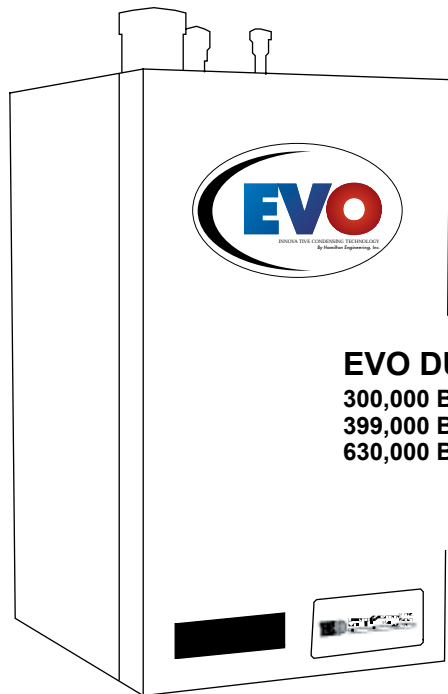

EVO DUO
300,000 BTU/hr
399,000 BTU/hr
630,000 BTU/hr

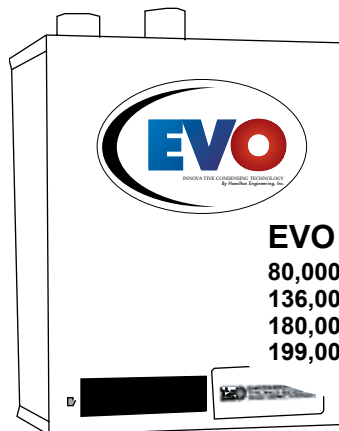

EVO MICRO
80,000 BTU/hr
136,000 BTU/hr
180,000 BTU/hr
199,000 BTU/hr



WARNING

If the information in this manual is not followed exactly, a fire or explosion may result causing property damage, personal injury or death.

Do not store or use gasoline or other flammable vapors and liquids in the vicinity of this or any other appliance.

WHAT TO DO IF YOU SMELL GAS:

- Do not try to light any appliance
- Do not touch any electrical switch
- Do not use any phone in your building

Immediately call your gas supplier from a neighbor's phone. Follow the gas supplier instructions. If you can not reach your gas supplier, call the fire department.



All models comply with
A S M E boiler code



ANSI STD Z21-13/Z21.13A
Certified to CSA 4.9-2004
ANSI STD Z21.10.3/Z21.10.3.b
Certified to CSA 4.1-2004, add.A,B

New York
MEA 425-05-E

Massachusetts
Boilers: G1-06-06-24A
Heaters: G1-06-06-24B

SCAQMD
Compliant Rule 1146.2

CEC Listed
California Energy Commission



WARNING

These appliances MUST be installed by a properly licensed individual in the City and State which the unit is being installed. All start up adjustments and subsequent service work must be done by a similarly licensed contractor or a factory trained service individual. Failure to comply could result in loss of warranty and or severe personal injury, death and or substantial property damage. ***These instructions are required to be kept with the appliance on the left side, in the pocket provided.***

USING THIS MANUAL

SPECIAL ATTENTION BOXES

Throughout this manual you will see these special attention boxes similar to this one, which are intended to supplement the instructions and make special notice of potential hazards. These categories are in the judgement of Hamilton Engineering, Inc.



DANGER

Indicates a condition or hazard which **WILL** cause severe personal injury, death, or major property damage.



WARNING

Indicates a condition or hazard which **WILL** cause severe personal injury, death, or major property damage.



CAUTION

Indicates a condition or hazard which **WILL** cause severe personal injury, death, or major property damage.



WARNING

- THE VENT SYSTEM MUST BE 2 PIPE SEALED COMBUSTION **CATEGORY IV** ONLY, PVC SCH 40 OR CPVC SCH 40 OR 80 OR AL 29-4C STAINLESS VENTING FOR ALL MODELS.
- THIS HEATER INSTALLATION MUST CONFORM TO THE LATEST EDITION OF THE "NATIONAL FUEL GAS CODE" ANSI Z223.1 NEPA 54 AND/OR CAN/CGAB149 INSTALLATION CODES. STATE AND LOCAL CODES MIGHT ALSO APPLY TO INSTALLATION.
- WHERE REQUIRED BY THE AUTHORITY HAVING JURISDICTION, THE INSTALLATION MUST CONFORM TO THE STANDARDS FOR CONTROLS AND SAFETY DEVICES FOR AUTOMATICALLY FIRED HEATERS, ANSI/ASME HEATER AND PRESSURE VESSEL CODE, SECTION IV, ALONG WITH CSD-1.
- THE HEATER, GAS PIPING, WATER PIPING, VENTING AND ELECTRICAL MUST BE INSTALLED BY TRAINED & QUALIFIED PERSONNEL FAMILIAR WITH INSTALLATION PRACTICES, LOCAL CODE, AND LICENSING REQUIREMENTS.
- IF THE INFORMATION IN THESE INSTRUCTIONS ARE NOT FOLLOWED EXACTLY, A FIRE OR EXPLOSION MAY RESULT, CAUSING PROPERTY DAMAGE, PERSONAL INJURY, OR DEATH.
- DO NOT STORE OR USE GASOLINE OR OTHER FLAMMABLE VAPORS AND LIQUIDS IN THE VICINITY OF THIS OR ANY OTHER APPLIANCE.

TABLE OF CONTENTS

Part 1 4-7

GENERAL INFORMATION

A How It Operates 4
 B EVO Dimensions 5-6
 C Pre-installation Requirements 6-7
 D Pressure Relief Valve 7

Part 2 8-9

ELECTRICAL

A Electrical Connection 8
 B Internal Wiring Connection 8-9

Part 3 10-14

GAS CONNECTION

A Gas Connection 10
 B Gas Piping 10
 C Gas Table 11
 D Gas Valve Set Up 11-12
 E Setting Maximum Load 12-13
 F Setting Minimum Load 13
 G Gas Conversion 13
 H Gas Valve Replacement 14

Part 4 14-20

VENTING

A Approved Venting Materials 14-15
 B Venting the EVO 15-18
 C Inlet Air Vent 19
 D Venting Runs Exceeding Maximum
 Combined Length 19
 E Heater Removal from a
 Common Vent System 19-20
 F Condensate Requirements 20

Part 5 20-22

PIPING

A Hydronic Heating Boiler Piping ... 20-21
 B Fill & Purge Heating System 21
 C Removing Air from Heat Exchanger ... 21
 D Water Heating Piping 22

Part 6 23-25

START UP PROCEDURES

A Items to be checked before
 lighting the EVO 23
 B Lighting Instructions 24
 C Operating Instructions 24
 D Adjusting the Temperature
 on the EVO Display 24
 E Sequence of Operation 25

Part 7 25-32

SERVICING

A Servicing the EVO 25
 B Placing EVO into Normal Operation... 25
 C Soft Lockout Codes 26
 D Hard Lockout Codes 26-27
 E Fault Causes 28-31
 F To Turn Off Gas to Appliance 31
 G Pump & Wiring Control 31
 H Temperature Sensor Reading
 Instructions 32
 I EVO Sensor Resistance Table 32

Part 8 33-48

MAINTENANCE & SPEC. INSTALLATION REQ.

A Maintenance Procedures 33
 B Annual Inspection 33
 C Condensate Cleaning Instructions ... 34
 D Combustion Chamber
 Coil Cleaning Instructions 34-35
 E EVO Controls 35-36
 F Installation at High Altitudes 36
 G Coil Scaling Prevention Feature
 (E-6 error codes) 36
 H Water Heater Operating Sample 37
 I EVO MICRO Parts Breakdown 38-39
 J EVO DUO Parts Breakdown 40-41
 K Universal Wiring Diagram 42
 L Installation Requirements
 (Massachusetts) 43

PART 1. GENERAL INFORMATION

A. HOW IT OPERATES

The EVO product line is an extremely high efficiency water heating product, requiring special venting and condensate removal precautions. Failure to follow all of the instructions contained in this manual may cause premature product failure that may not be covered under warranty.

This appliance has built-in freeze protection, automatically activating the circulation pump when the internal water temperature drops below 41°F. If the internal water temperature drops to 37°F, a burn cycle will be initiated and will shut down as soon as the supply water temperature has reached 50°F. *Power must be left on for this function to operate.*

The appliance's primary controller (FMT 914) operates all functions of needed control and safety. It contains sophisticated logic that allows it to operate at very precise temperatures while minimizing burner on/off cycling. When multiple units are operated as a Cascade to handle a common load, the control contains the ability to control all of the units as efficiently as one. *Cascade operation is a factory-installed and programmed option, requiring a field wiring connection between appliances for operation.*

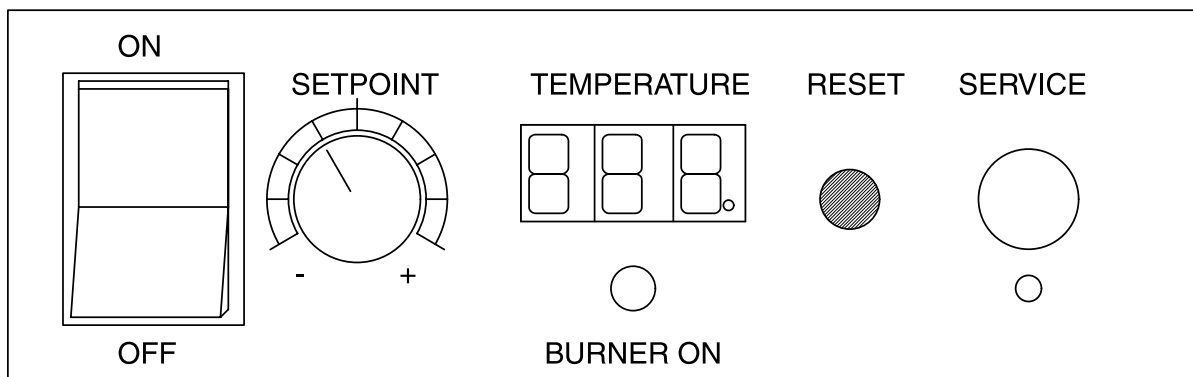

Looking at the controls on the front of the appliance,

- 1) POWER on/off switch
- 2) SETPOINT knob, temperature control (and fan speed control knob during service mode)
- 3) TEMPERATURE setpoint display
 - a. Temperature in °F, corresponding to the SETPOINT knob
 - b. Display will always read temperature setpoint unless there is a fault code displayed.
 - c. Cascade indicator light, found in the lower right hand corner of the Temperature display. This dot will be flashing when this appliance is part of a properly-connected, commonly-controlled group of EVO products and reading temperature sensors.
 - d. Display code, not flashing indicates a Soft Lockout
 - e. When this display is flashing a code, the appliance is in a Hard Lockout and the reset must be pushed to re-start the appliance.
- 4) Green indicating light labeled BURNER ON; when lit, the burner is firing.
- 5) RESET button, used as described in 3e above, as well as to view sensors and set altitude (see pages 32 & 36 respectively for details).
- 6) SERVICE port, used for connecting a computer to the appliance to download the service fault history, as well as factory setting of control board parameters. There is a service button located just below the service port that must be pressed with a pointed object to get to the service mode.

B. EVO DIMENSIONS

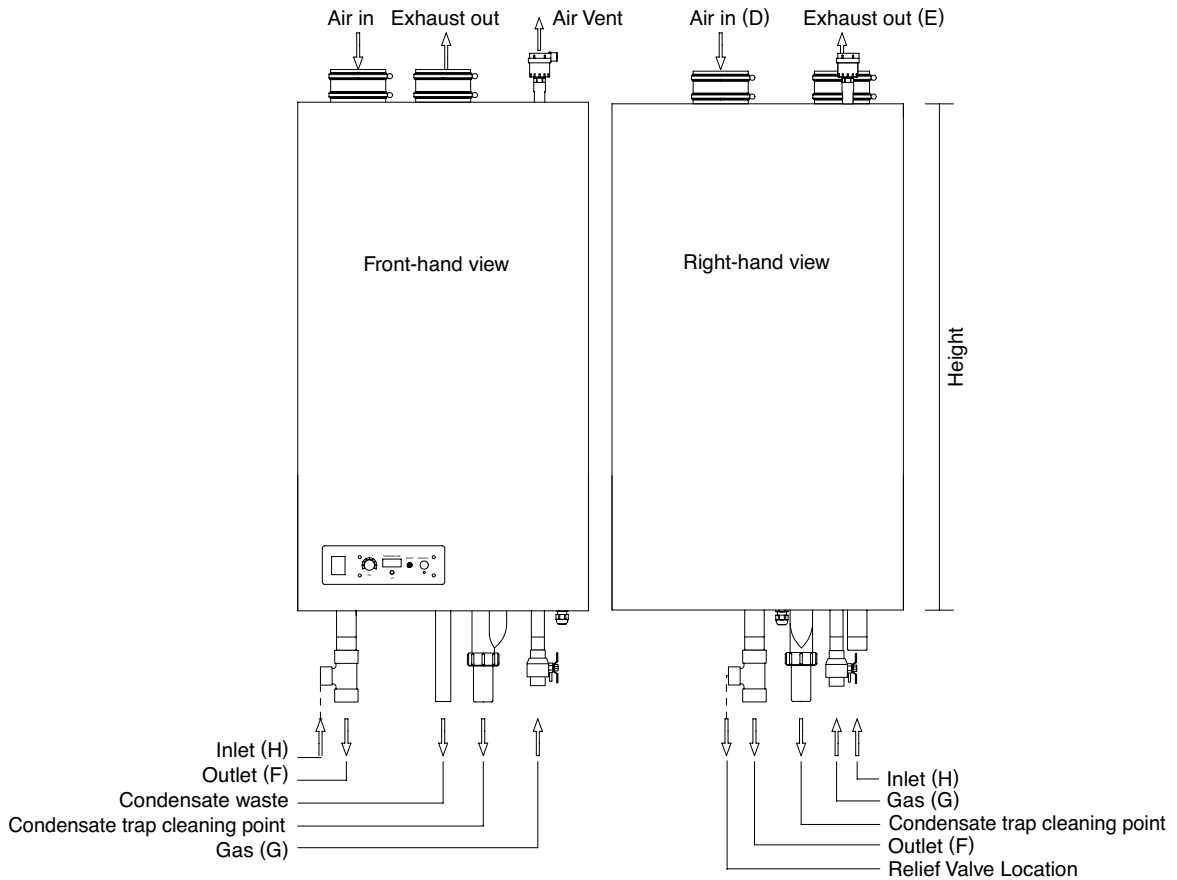

**(FIGURE 1-1)
EVO DIMENSIONS**

Model	Width	Height	Depth	D	E	F (FPT)	G	H (MPT)
79-129	16"	20.5"	12"	3"	3"	1.0"	0.75"	1.0"
179-199.1	16"	20.5"	12"	3"	3"	1.0"	0.75"	1.0"
199	19"	33"	19"	3"	3"	1.5"	0.75"	1.5"
299	19"	33"	19"	3"	3"	1.5"	0.75"	1.5"
399	19"	33"	19"	4"	4"	2.0"	0.75"	1.5"
599	19"	35"	26.5"	5"	5"	2.0"	1.0"	1.5"

(TABLE 1-1) EVO INFORMATION

Model	Input BTU/hr	Water Heater* Output BTU/hr	Boiler** Output BTU/hr	GPH* Recovery @100°F T	GPH* Recovery @80°F T	GPH* Recovery @60°F T	Shipping Weight
HW 79	80,000	77,600	74,800	93	116	155	77 lbs.
HW 129	136,300	132,890	127,441	160	199	265	77 lbs.
HW 179	186,000	181,002	168,300	217	272	362	91 lbs.
HW 199.1	199,999	193,999	186,999	233	291	388	91 lbs.
HW 199	199,999	193,999	186,999	233	291	600	112 lbs.
HW 299	300,000	291,000	280,500	360	450	600	111 lbs.
HW 399	399,999	387,999	373,999	466	582	776	194 lbs.
HW 599	630,000	611,100	589,050	734	917	1223	234 lbs.

*At 97% thermal efficiency with 86°F incoming water to heat exchanger

**At 95% thermal efficiency with 140°F incoming water to heat exchanger

RECOMMENDED SERVICE CLEARANCES

(FIGURE 1-2) EVO CLEARANCES

(NOTE: The EVO is rated at zero clearance to combustibles.)

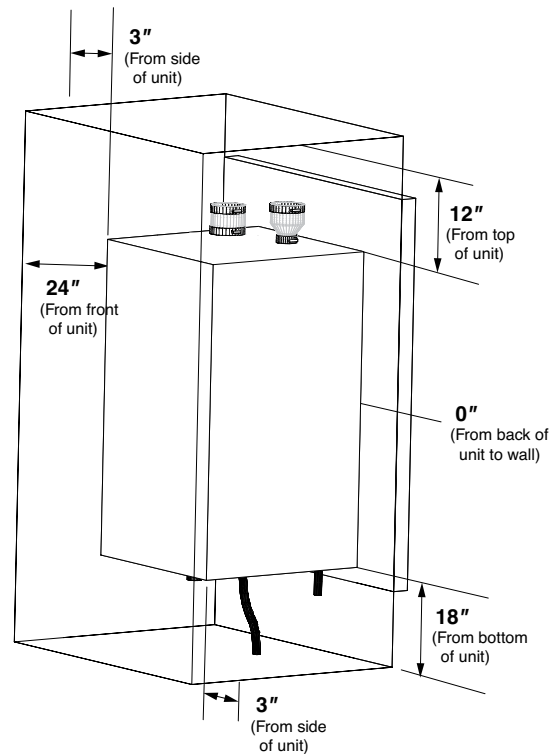

C. PRE INSTALLATION REQUIREMENTS

The EVO MICRO is designed to be wall mounted using the supplied mounting bracket or a factory supplied frame. Details are shown in Figure 1-3. The EVO DUO must be installed using a factory supplied frame or rack system. **The EVO DUO is substantially heavier than traditional wall mounted appliances, caution must be exercised when choosing a mounting surface if the leg portion of a rack system is not used. Please see uninstalled unit weights on page 5.** It can be installed in alcoves, basements, utility rooms as well as standard equipment rooms. Choose a location for your EVO, centralized to the piping system, along with consideration for Electrical (Part 2, Page 8), Gas Connection (Part 3, Page 10), Venting (Part 4, Page 14), and Condensate Drain (Part 4, Section F, Page 20).

The EVO heat exchanger must be level as installed, and the mounting surface must be designed to support the weight (see previous page, Table 1-1 for weights). Be sure the appliance is adequately secured to the mounting surface.

The front cover is secured by a threaded screw and two clasp style latches; it can only be installed one way. **When removing the front cover of the EVO unit, you must make sure all electric power to the appliance is turned off.** Then remove the screw at the bottom of the panel, undo the latches and remove the cover (see Figure 1-4 on the next page).

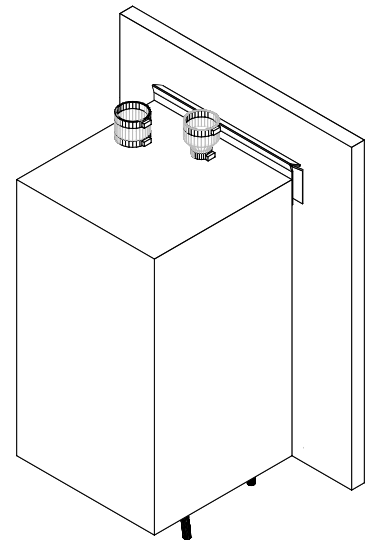

(FIGURE 1-3) EVO MOUNTING DETAIL

If the EVO is set up for liquefied petroleum (LP) gas, some geographic areas follow the Uniform Mechanical Code, section 304.6, "Liquefied petroleum gas burning appliances shall not be installed in a pit, basement or similar location where heavier-than-air gas might collect. Appliances so fueled shall not be installed in a below grade under-floor space or basement **unless such location is provided with an approved means for removal of unburned gas.**"

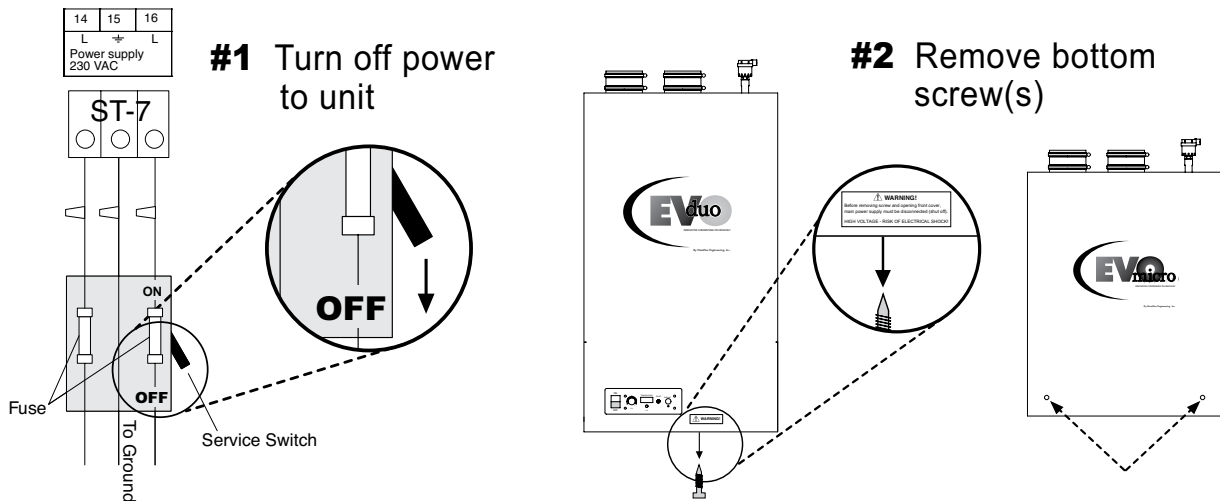

(FIGURE 1-4) HOW TO REMOVE THE FRONT COVER



WARNING

The EVO is certified as an indoor appliance. Do not install the EVO outdoors or locate where it will be exposed to freezing temperatures. This includes all related piping and components. If the EVO is subjected to flood water or submersed in water, the EVO must be replaced.



NOTICE

Condensation Removal: This is a condensing, high efficiency appliance, therefore condensation removal must be addressed to avoid damage to surrounding area or appliance. See Part 4, Section F for Condensate Requirements (pg.20).

D. PRESSURE RELIEF VALVE

This unit is supplied with a relief valve sized in accordance with ANSI/ASME Heater and Pressure Vessel Code, Section IV. The relief valve is installed near the hot water outlet. If the valve supplied is replaced, the pressure rating of the valve must not exceed the listed working pressure of this appliance, and must be rated to the proper BTU/hr capacity of the water heater. **Do not, under any circumstances, thread a cap or plug into the relief valve! Explosion, serious injury or death may result!** To prevent water damage, the relief valve piping must be directed to the floor or an open drain, but not connected directly. There must be a 6" space between the outlet of relief valve piping and drain or floor. Do not hook up to drain system directly without an air gap. Protect from freezing. Place no other valve between the relief valve and the unit. Do not install any reducing couplings or other restrictions in the discharge line. The discharge line must allow complete drainage of the valve and line. Manually operate the relief valve at least once a year.

Also, care must be exercised when choosing the location of this appliance, where leakage from the relief valve, leakage from related piping, or leakage from the tank or connections, will not result in damage to the surrounding areas, or to the lower floors of the building. A water heating appliance should always be located in an area with a floor drain or installed in a drain pan suitable for water heating appliances. Under no circumstances, shall Hamilton Engineering, Inc. be held liable for any such water damage whatsoever.

PART 2. ELECTRICAL

A. ELECTRICAL CONNECTION

The electrical connection for the EVO is on the bottom of the unit. There is a 1/2" knockout location for an electrical connection for the heater's incoming power connection. All electrical wiring must be performed by a qualified licensed electrician in accordance with National Electrical Code ANSI/NEPA to and/or the Canadian Electrical Code, Part 1 CSA C22.1, or to the applicable codes and standards. For your convenience, we have labeled all the points for electrical connections needed to operate the EVO.

The electrical requirements are for standard 208–240 volts, 50/60 Hz 15 Amp service. This unit is wired with #18 awg and internally fused for no more than 3.15 Amps. When the unit is first powered on, there is a self-setting of the electronics for 50 Hz or 60 Hz. At every power up, the electronics will take a couple of seconds to compare the pulses of the power to the pulses of the crystal, which is built into the electronics. Then all time-related functions are correct no matter the power source..

The standard supplied pumps are all 208–240 volt, 60 cycle and are wired to terminals on the heater. In 50 cycle applications, other pumps may need to be supplied, depending on water conditions. With the 914 controller there is an ability to program a custom pump delay time, or to use a continuous (no time out) setting. The factory default is a 1 minute delay to turn off after completing a burn cycle.

B. INTERNAL WIRING CONNECTION



CAUTION

The incoming power shall be connected directly to the labeled, intended connection points only. Failure to do so may result in an electrical short and the control board will have to be replaced!



DANGER

**IT IS EXTREMELY IMPORTANT THAT THIS UNIT BE PROPERLY GROUNDED!
IT IS VERY IMPORTANT THAT THE BUILDING GROUND IS INSPECTED BY A
QUALIFIED ELECTRICIAN PRIOR TO MAKING THIS CONNECTION!**

Terminal 19 in the electrical compartment must be connected to the building ground system.

The incoming 208–240 volt single phase power supply is connected to terminals 26 through 28.

It is important that the electrical power is not turned on at this time. Double check all connections and then turn the power on. The display that is provided with the EVO should now be reading the Setpoint temperature.

Note: See Start-Up Procedures (Part 6, Page 23) to change the temperature setting or run the appliance.

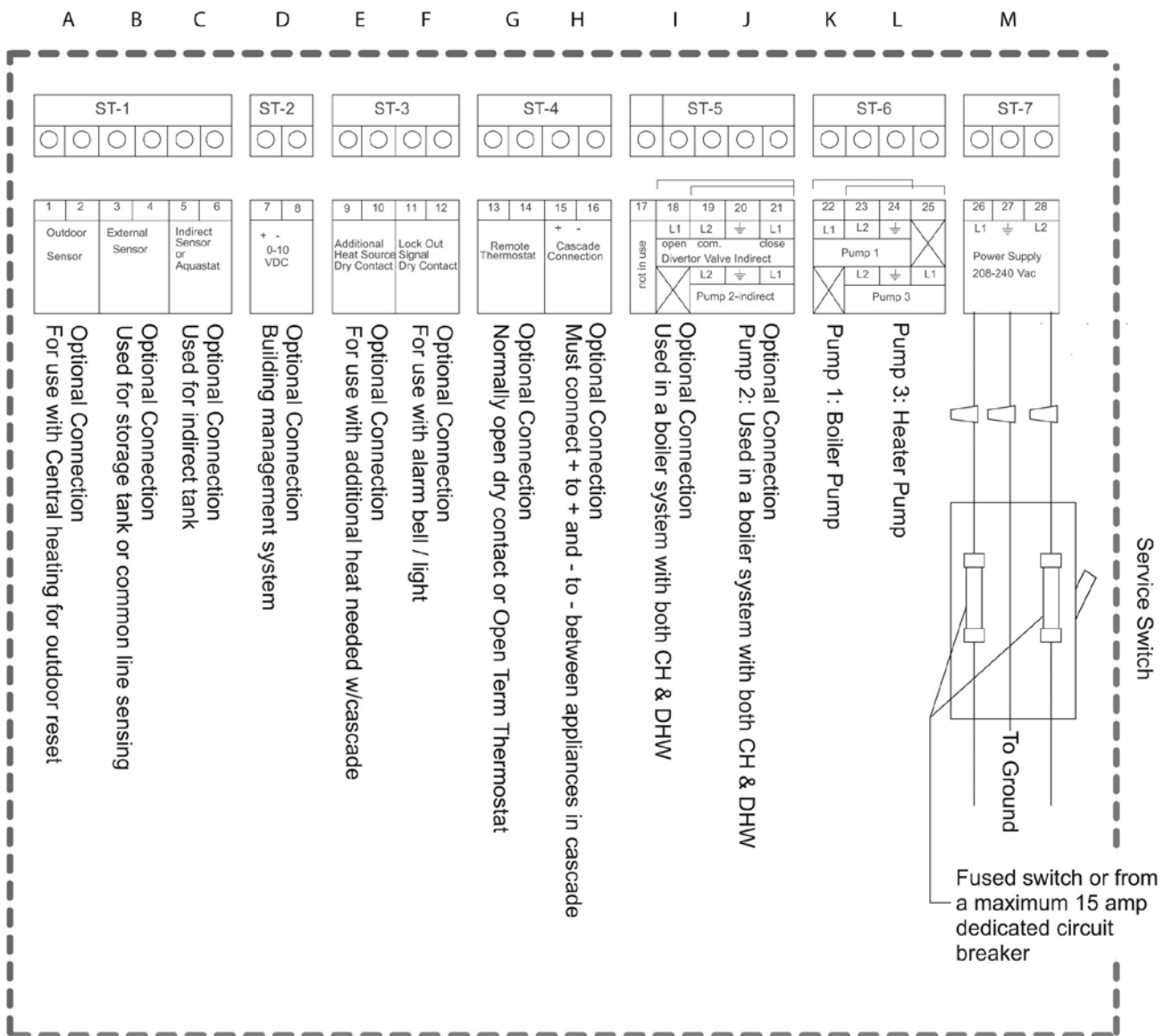

(FIGURE 2-1) FIELD WIRING CONNECTIONS

- A. Outdoor Sensor - outdoor air sensor, set point will adjust based on outdoor air temperature (not needed if 0-10 VDC output is connected)
- B. External sensor connection - system temperature sensor, senses water temp in a storage tank or a heating loop.
- C. Indirect Tank Sensor - Sensor for indirect DHW. An aquastat may also be connected here.
- D. 0-10 VDC - connect a 0-10 VDC output here to vary set point temperature.
- E. Additional Heat Source - dry contacts that will close a thermostat on an extra heater/boiler if the cascade system is at 100% of capacity.
- F. Lock Out Signal - alarm bell or light may be connected here.
- G. Remote Thermostat - normally jumped. A room thermostat may be connected here to enable/disable the heater/boiler.
- H. Cascade Connection - communication cables get connected here and "daisy chained" to all heaters/boilers in a cascade. This is polarity sensitive.
- I. 3- Way Diverter Valve - Used in a boiler system with both Heating and Indirect Hot Water.
- J. P2 - Pump for indirect. Used in a boiler system with both Heating and Indirect Hot Water.
- K. P1 - Wire to primary pump for boilers.
- L. P3 - Wire to primary pump for heaters or system pump for boilers.
- M. Power Supply - main power connections in the electrical box originate here.

PART 3. GAS CONNECTION

A. GAS CONNECTION



WARNING

Failure to follow all precautions could result in fire, explosion or death!

The gas supply shall have a maximum inlet pressure of less than 14" water column (1/2 PSI) (3.44 kPa), and a minimum of 4" water column. The entire piping system, gas meter and regulator must be sized properly to prevent pressure drop greater than 1" as stated in the National Fuel Gas Code. This information is listed on the rating plate. **It is very important that you are connected to the type of gas as noted on the rating plate**, "LP" for liquefied petroleum, propane gas or "Nat" for natural or city gas. All gas connections must be approved by the local gas supplier, or utility in addition to the governing authority, prior to turning the gas supply on. It is mandatory that a drip leg be fabricated, as per the National Fuel Gas code. Once all the inspections have been performed, the piping must be leak tested. It is recommended that a soapy solution be used to detect leaks. Bubbles will appear on the pipe to indicate a leak is present. If the leak test requirement is a higher test pressure than the maximum inlet pressure, you must isolate the EVO from the gas line. In order to do this, you must shut the gas off using factory and field-installed gas cocks (following the lighting instructions in Part 6, Section B, Page 24.) This will prevent high pressure from reaching the valve. Failure to do so may damage the gas valve. In the event the gas valve is exposed to a pressure greater than 14" water column, the gas valve must be replaced.

Never use an open flame (match, lighter, etc.) to check gas connections.

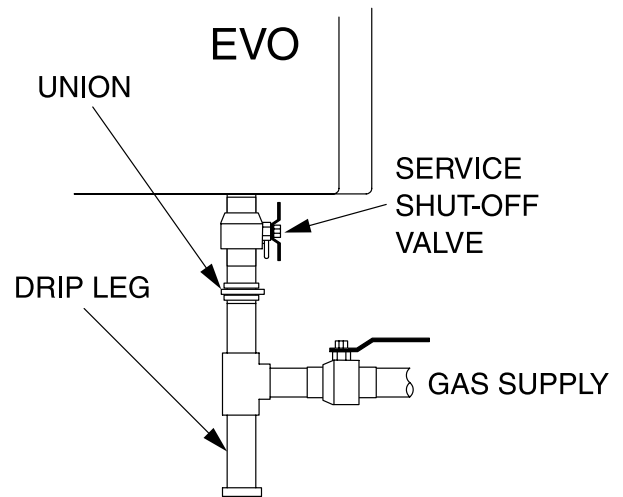

(FIGURE 3-1) EVO GAS CONNECTION

B. GAS PIPING

The gas piping must be sized for the proper flow and length of pipe, to avoid pressure drop. Both the gas meter and the gas regulator must be properly sized for the total gas load. If you experience a pressure drop greater than 1" WC, the meter, regulator or gas line is undersized or in need of service. You can attach a manometer to the incoming gas drip leg, by removing the cap and installing the manometer, see Figures 3-2 and 3-3. The gas pressure must remain between 4" and 14" during stand-by (static) mode and while in operating (dynamic) mode. **If an in-line regulator is used, it must be a minimum of 10 equivalent feet from the EVO. It is very important that the gas line is properly purged by the gas supplier or utility. Failure to properly purge the lines or improper line sizing, will result in ignition failure.** This problem is especially noticeable in NEW LP installations and also in empty tank situations. This can also occur when a utility company shuts off service to an area to provide maintenance to their lines. This gas valve must not be replaced with a conventional gas valve under any circumstances. As an additional safety feature, this gas valve is easily de-coupled from the fan inlet.

Refer to the following tables to size the supply piping to minimize pressure drop between meter or regulator and unit.

C. GAS TABLES

(TABLE 3-1) NATURAL GAS SUPPLY PIPING

Nominal Iron Pipe	Internal Diameter	Length of Pipe (Feet)													BTUs per HR x 1,000
		10	20	30	40	50	60	70	80	90	100	125	150	200	
3/4	0.824	363	249	200	171	152	138	127	118	111	104	93	84	72	}
1	1.049	684	470	377	323	286	259	239	222	208	197	174	158	135	
1-1/4	1.380	1,404	965	775	663	588	532	490	456	428	404	358	324	278	
1-1/2	1.610	2,103	1,445	1,161	993	880	798	734	683	641	605	536	486	419	
2	2.067	4,050	2,784	2,235	1,913	1,696	1,536	1,413	1,315	1,234	1,165	1,033	936	801	

(Based on 0.60 specific gravity for natural gas at 0.5" WC pressure drop; DOE standard is 1100 BTU per cubic foot of natural gas.)

1. Run the gas supply line in accordance with all applicable codes.
2. Locate and install manual shut off valves in accordance with state and local requirements.

(TABLE 3-2) PROPANE SUPPLY PIPING (Based on 11" WC supply pressure)

Nominal Iron Pipe	Internal Diameter	Length of Pipe (Feet)													BTUs per HR x 1,000
		10	20	30	40	50	60	70	80	90	100	125	150	200	
3/4	0.824	567	393	315	267	237	217	196	185	173	162	146	132	112	}
1	1.049	1,071	732	590	504	448	409	378	346	322	307	275	252	213	
1-1/4	1.380	2,205	1,496	1,212	1,039	913	834	771	724	677	630	567	511	440	
1-1/2	1.610	3,307	2,299	1,858	1,559	1,417	1,275	1,181	1,086	1,023	976	866	787	675	
2	2.067	6,221	4,331	3,465	2,992	2,646	2,394	2,205	2,047	1,921	1,811	1,606	1,496	1,260	

D. GAS VALVE SETUP

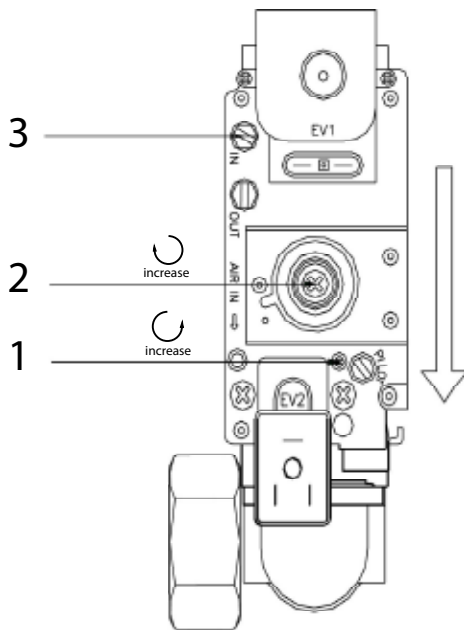

(FIGURE 3-2) EVO MODELS 79-399

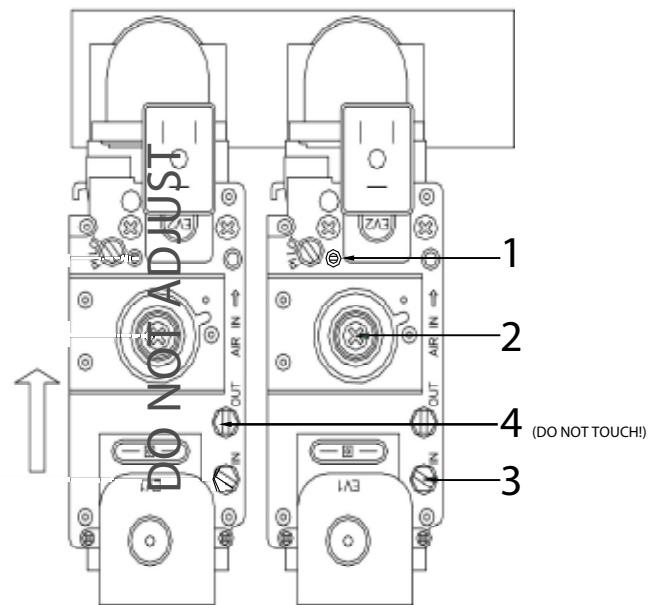

(FIGURE 3-3) EVO MODEL 599

GAS CONNECTION

Measure the gas supply pressure at the pressure nipple [3] of the gas valve. The required gas supply pressure needed for these appliances to work properly is greater than 4" and less than 14" WC. This pressure range should be maintained during full gas load on the building where the appliance is installed.

(TABLE 3-3) COMBUSTION & FUEL RELATED ADJUSTMENT TABLE

	Natural Gas CO ₂		Natural Gas CO ppm	LP Gas CO ₂		LP Gas CO ppm
	Cover On	Cover Off	Approximate, do not use for setup!	Cover On	Cover Off	Approximate, do not use for setup!
LOW FIRE	8.5%	8.3%	Less than 10	9.6%	9.4%	Less than 15
HIGH FIRE	8.8%	8.6%	Less than 110	10.0%	9.8%	Less than 120

Please note: All adjustments must be made with the appliance door off, which will lower the CO₂ reading 0.2%. See tables above for specific readings.

Changing incoming air temperature may vary the CO₂ setting slightly (~0.2 - 0.6%) after initial set up. This is not cause for concern or reason to set up again. After one year of operation, set up is required again.

E. SETTING THE MAXIMUM LOAD

A means of sampling the leaving flue gas is built into each model, on all models there is a rubber plug mounted in the vent connector on top of the appliance. Remove for testing and replace when testing is completed. This plug **MUST** be in place during normal operation.

- Press the service button with a pointed object and set the temperature knob on the maximum fan speed as shown by model in the table below (*RPM = display * 100, ex. 060 = 6000*).

(TABLE 3-4) FAN SPEED REQUIREMENTS

Last 4 digits of serial number		HWD 79, HWH 79, HWH 79.8	
First Week	Last Week	Maximum rpm	Minimum rpm
02--08	current	6400	1856

Last 4 digits of serial number		HWD 129, HWH 129, HWH 129.8	
First Week	Last Week	Maximum rpm	Minimum rpm
49--06	current	5900	1947

Last 7 digits of serial number		HWD 179, HWH 179, HWH 179.8	
First Week	Last Week	Maximum rpm [^]	Minimum rpm
009-43-07	023-48-07	5800	1856
009-43-07	008-48-07	5600	1680
024-11-08	current	5600	1736

[^] Fan speeds 5800 & 6000 rpm require Hamilton P/N FAN 74313, 5600 rpm requires FAN 74351.

Last 4 digits of serial number		HWD 199, HWD 199.1, HWH 199, HWH 199.1, HWH 199.8	
First Week	Last Week	Maximum rpm	Minimum rpm
49--06	current	6500	1755

Last 4 digits of serial number		HWD 299	
First Week	Last Week	Maximum rpm	Minimum rpm
02--08	current	6300	1575

Last 4 digits of serial number		HWD 399	
First Week	Last Week	Maximum rpm	Minimum rpm
24--05	current	6200	1798

Last 4 digits of serial number		HWD 599	
First Week	Last Week	Maximum rpm	Minimum rpm
24--05	current	5700	1596

Do not forget to place the knob, labeled with “Setpoint,” at the proper temperature value when done.

If necessary, turn the adjusting slot [1], which sets the high fire performance, either counterclockwise to increase the CO2 percentage or clockwise to reduce the CO2 percentage, as shown in Figures 3-2 and 3-3, page 11. Appropriate CO2 percentages are shown in Table 3-3 on previous page.

F. SETTING THE MINIMUM LOAD

Set the minimum load once the maximum load has been set, turn the knob until the minimum RPM setting has been reached. In order to set or adjust the minimum load, turn the screw [2] for the minimum setting (first remove the protective cap). Turn the screw clockwise to increase or counter clockwise to decrease the CO2 percentage. On the HW 599, you only are allowed to set the gas valve at the right side; the left gas valve is set by the manufacturer. *See Section H for special instructions on replacing both gas valves in a model 599.*

- If the measuring process takes more than 40 minutes, the appliance will return to the automatic mode. If so required, press the Service button another time.
- When you are done setting the valve, press the Service button again to return to normal run mode

Please do not forget to replace the protective cap on the gas valve!

G. GAS CONVERSION

If the appliance is to be converted in the field for using Propane (LPG), the following steps must be taken:

- Turn screw [1] (Figure 3-2) .75 of a full turn (270°) on models HW 79/199.1, three quarters of one turn (270°) on models HW 199/299 and 1 full turn (360°) on model HW399
- On model HW599 (Figure 3-3) turn screw on left hand valve closed (clockwise) and turn right valve 1.75 of a full turn clockwise.
- Run the appliance. If the burner does not ignite after four starting efforts, turn the screw [1] one half turn back (180°) (counter clockwise).
- After conversion, follow the steps in Sections E and F for setting the maximum and minimum loads, using the LP gas values shown in Table 3-3.

H. GAS VALVE MAINTENANCE/REPLACEMENT

- 1) When checking or replacing a gas valve, the CO2 percentage in the flue gas is the preferred measuring method to insure proper combustion and firing rate. CO is used as the alternate.
- 2) Gas valve replacement for the HW 599:

The left hand gas valve (which is normally factory-set and sealed and must not be adjusted) must be set up to factory specifications before any combustion related adjustments can be performed on the right hand valve. An electronic manometer must be used, as it will be set to a scale of 0.01" WC.

The adjustment screw [1] (see Figure 3-3) normally used for setting maximum flow rate must be turned counter-clockwise until it begins to click when turned. The screw will not fall out, but will be fully retracted at this point. this is for Natural Gas, for LP gas, close the left hand valve (clockwise) until it is closed down.

The digital manometer must now be connected to the outlet pressure tapping [4] on the left hand valve only (marked do not adjust in figure 3-3 page 11), and the appliance fired. It must be placed in the service mode and held at the minimum firing rate (1653 rpm fan speed). With the appliance firing at this rate, adjust the offset (minimum firing rate) screw [2] to a pressure of "0" +/- .001" WC. **Be sure the manometer has been zeroed out prior to making this setting.**

Once this operation is complete, you may follow the instructions for setting the minimum and maximum firing rate as shown in Sections G and H, **for the right hand gas valve only.**

⚠ WARNING

Failure to follow all precautions could result in fire, explosion or death!

⚠ DANGER

It is extremely important to follow these venting instructions carefully. Failure to do so can cause sever personal injury, death or substantial property damage.

PART 4. VENTING

A. APPROVED VENTING MATERIALS

All vent pipe materials and fittings must comply with the following:

Item	Material	Standards for installation in:	
		United States	Canada
Vent pipe and fittings	PVC schedule 40	ANSI/ASTM D1785	CPVC and PVC venting must be ULC-S636 Certified. IPEX is an approved vent manufacturer in Canada supplying vent material listed to ULC-S636.
	PVC - DVW	ANSI/ASTM D 2665	
	CPVC schedule 40	ANSI/ASTM F441	
Pipe cement & primer	PVC	ANSI/ASTM D2564	IPEX System 636 Cements & Primers
	CPVC	ANSI/ASTM F493	

NOTICE: DO NOT USE CELLULAR (FOAM) CORE PIPE

Please note: Venting system may contain one or more of the above materials.

The EVO is a direct vent appliance. The EVO is listed as a Category IV. Condensing Appliance. (The EVO Venting is rated at Zero Clearance to combustibles.)



DANGER

It is extremely important to follow these venting instructions carefully. Failure to do so can cause severe personal injury, death or substantial property damage.



WARNING

This vent system will operate with a positive pressure in the vent pipe. Do not connect vent connectors serving appliances by natural draft into any portion of mechanical draft systems operating under pressure.

Note: For concrete construction or to meet certain fire codes, exhaust and inlet piping at the wall penetration to the EVO must be CPVC Schedule 40 or 80 or stainless. The balance from the penetrated wall to the outside may be PVC Schedule 40 or 80.

B. VENTING THE EVO

(TABLE 4-1) VENTING SPECIFICATIONS

Model	Vent Diameter	Standard Vent Type	Optional Vent Type	Minimum combined vent length	Maximum combined length
HW 79	3"	Plastic	Stainless	6' + (2) 90° elbows	225'
HW 129	3"	Plastic	Stainless	6' + (2) 90° elbows	200'
HW 179	3"	Plastic	Stainless	6' + (2) 90° elbows	200'
HW 199.1	3"	Plastic	Stainless	6' + (2) 90° elbows	100'
HW 199	3"	Plastic	Stainless	6' + (2) 90° elbows	95'
HW 299	4"	Plastic	Stainless	6' + (2) 90° elbows	3"=30' 4"=225'
HW 399	4"	Plastic	Stainless	6' + (2) 90° elbows	180'
HW 599	5"	Stainless	Plastic - 6" *	6' + (2) 90° elbows	200'

* The use of 6" PVC will require the purchase of a special adapter from Hamilton Engineering, Inc.

(TABLE 4-2) EQUIVALENT FEET

Fittings or Piping	Equivalent Feet
90 degree elbow	5'
45 degree elbow	3'
Coupling	0
Air inlet elbow	6'
Exhaust coupling	1'

The inlet and exhaust pipes on the top of the cabinet should be the diameter and material indicated in the Venting Specifications Table above. It is very important that you plan the location properly to eliminate long pipe runs and excessive fittings. Inlet pipe size must not be reduced. *Do not combine the inlet air or exhaust with any other inlet or exhaust pipe including either to an additional similar appliance, unless you have purchased an engineered Common Venting System from Hamilton Engineering, Inc.* The joints must be properly cleaned, primed and cemented if plastic, and sealed per the manufacturer's instructions if stainless. The piping must also be properly supported as per Local and National Standard Plumbing Codes. It is important that the piping must be clean and free from burrs, debris, ragged ends and particles of PVC (if applicable).

Exhaust piping should be sloped back to the connection on the EVO, at least 1/4" per foot to remove additional condensate that forms within the pipe. The total combined length of pipe (intake piping plus exhaust piping added together) including elbow allowances intake and exhaust should not exceed the length shown in the vent table. The minimum combined vent length should not be less than a combined length of 6' plus two 90° elbows. Choose your vent termination locations carefully. You must also make certain that exhaust gas does not re-circulate back into the intake pipe. You must place them in an open area and follow the following guidelines:



NOTICE

The following are code restrictions for the location of the flue gas vent terminal. Compliance to these requirements doesn't insure a satisfactory installation; good common sense must also be applied. It is important to make sure that exhaust gases are not recirculated into the inlet air of the EVO. If there is any doubt, contact the factory BEFORE installing.

- 1) Never vent into a walkway, patio area, alley or otherwise public area less than 7' from the ground. (See detail below references Fig. A.12.9 in the National Fuel Gas Code 2009 "Exit Terminals of Mechanical Draft and Direct-Venting Systems." - see Figure 4-1, pg.17)
- 2) Never vent over or under a window or a doorway where the exhaust plume or condensation liquid will cause obtrusive or dangerous conditions. (Refer to National Fuel Gas Code, CAN B149).
- 3) Never install a heat saver or similar product to capture waste heat from exhaust.
- 4) Always have a vent location at least 12" above maximum snow level.
- 5) Always have vent a minimum of 24" above ground level, away from shrubs and bushes.
- 6) Follow local gas codes in your region or refer to National Fuel Gas Code, Can B149.
- 7) Always have at least 36" distance from an inside corner of the outside walls.
- 8) Maintain at least 48" clearance to electric, gas meters, windows, exhaust fans, chimneys, inlets or mechanical vents.
- 9) VERY IMPORTANT! The inlet air connection must be connected to outside air and should be located no closer than 8" and no further than 24" to the exhaust.
- 10) *Always* place screens in all openings in intake and exhaust to prevent foreign matter from entering the EVO.
- 11) The vent intake and exhaust must be properly cleaned and glued if plastic, and sealed per the manufacturer's directions if stainless for a pressure tight joint. Several methods for venting the EVO can be found in Figures 4-2 and 4-3 of this section, on page 18. Use these layouts as guidelines: certain site conditions such as multiple roof lines/pitches may require venting modifications (consult Hamilton Engineering, Inc.).

***IMPORTANT NOTE**

HAMILTON ENGINEERING, INC. RECOMMENDS A MINIMUM CLEARANCE OF 4 FEET WHERE THE EXHAUST PLUME CAUSED BY THE UNIT MAY OBSTRUCT VIEWS OR AFFECT THE COSMETIC LOOK OF THE BUILDING. IN CANADA, THERE IS A MINIMUM CLEARANCE OF 10 FEET.

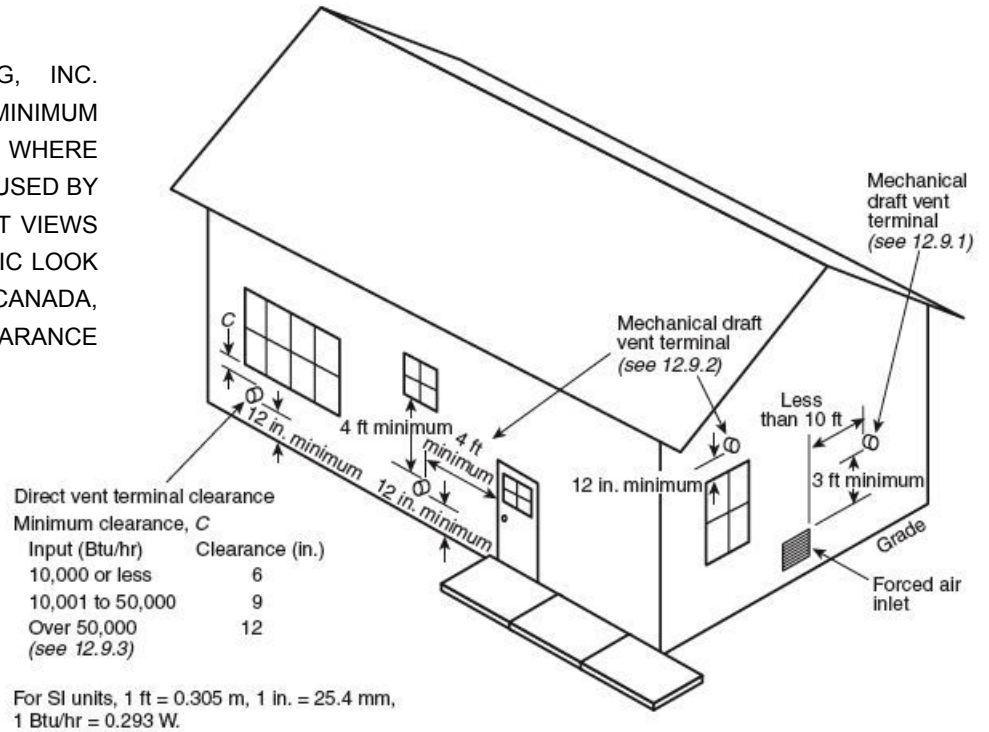

(FIGURE 4-1) EXIT TERMINALS OF MECHANICAL DRAFT AND DIRECT-VENT VENTING SYSTEM
 * REFERENCE: THE NATIONAL FUEL GAS CODE 2009 EDITION

Through-the-Wall Vent Termination

12.9.1 A mechanical draft venting system shall terminate at least 3 ft (0.9 m) above any forced air inlet located within 10 ft (3 m).

Exception No. 1: This provision shall not apply to the combustion air intake of a direct vent appliance.

Exception No. 2: This provision shall not apply to the separation of the integral outdoor air inlet and flue gas discharge of listed outdoor appliances.

12.9.2 A mechanical draft venting system of other than direct vent type shall terminate at least 4 ft (1.2 m) below, 4 ft (1.2 m) horizontally from, or 1 ft (300 mm) above any door, operable window, or gravity air inlet into any building. The bottom of the vent terminal shall be located at least 12 in. (300 mm) above finished ground level.

12.9.3 The vent terminal of a direct vent appliance with an input of 10,000 Btu/hr (3 kW) or less shall be located at least 6 in. (150 mm) from any air opening into a building, an appliance with an input over 10,000 Btu/hr (3 kW) but not over 50,000 Btu/hr (14.7 kW) shall be installed with a 9 in. (230 mm) vent termination clearance, and an appliance with an input over 50,000 Btu/hr (14.7 kW) shall have at least a 12 in. (300 mm) vent termination clearance. The bottom of the vent terminal and the air intake shall be located at least 12 in. (300 mm) above finished ground level.

DIAGRAMS FOR SIDEWALL VENTING

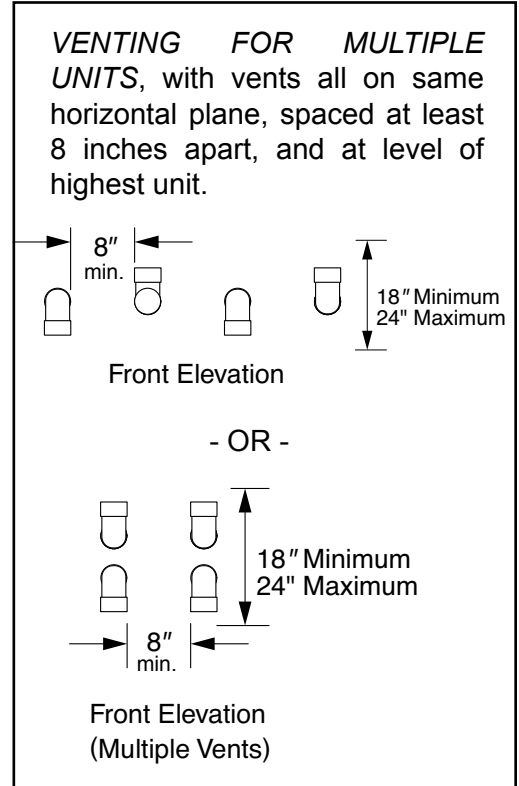
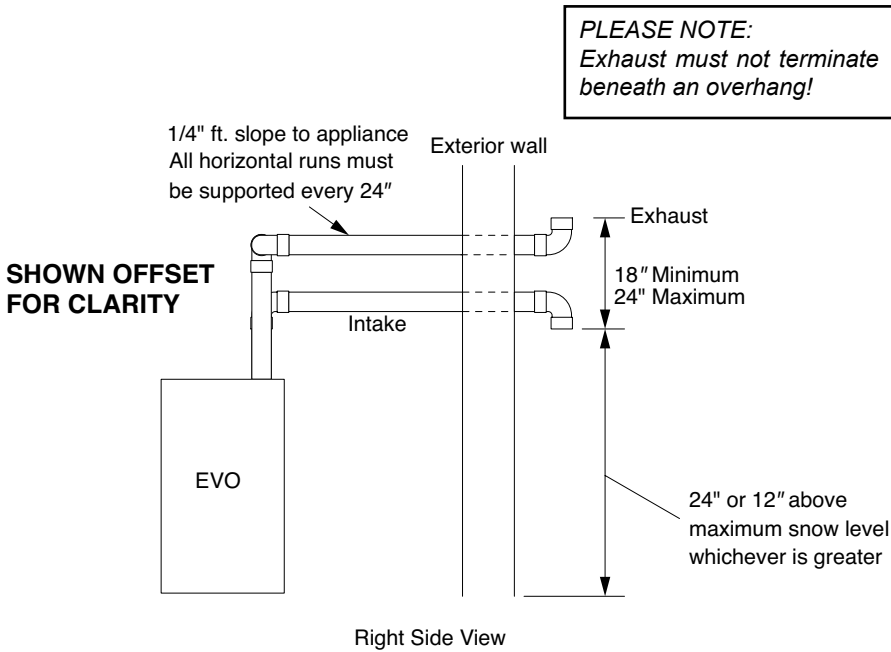

(FIGURE 4-2) SIDEWALL VENT WITH DOWN ELBOW (INTAKE) & UP ELBOW (EXHAUST)

****IMPORTANT NOTE:** All vent pipes must be glued, properly supported and the exhaust must be pitched a minimum of a 1/4" per foot back to the heater (to allow drainage of condensate). All stainless venting must be sealed at each joint per manufacturer's instructions.

DIAGRAMS FOR VERTICAL VENTING

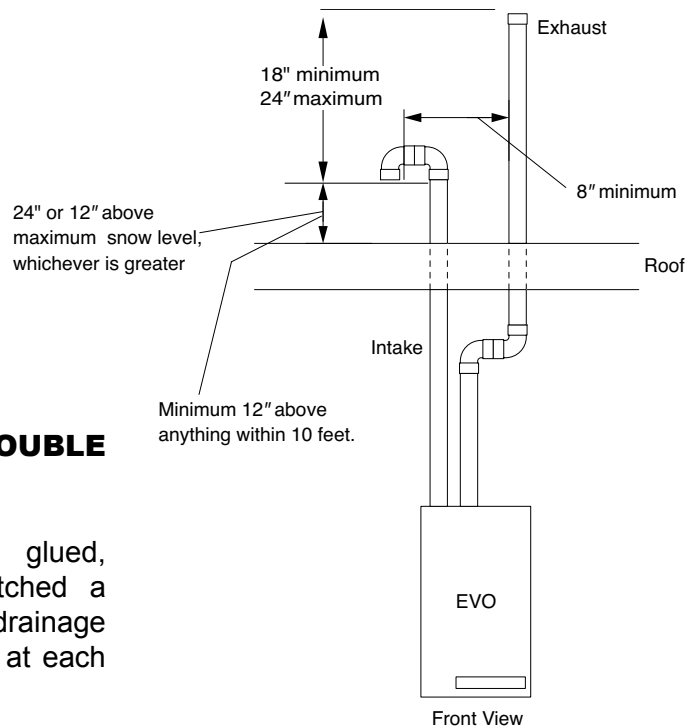

(FIGURE 4-3) VERTICAL VENT WITH DOUBLE ELBOW (INTAKE) & COUPLING (EXHAUST)

****IMPORTANT NOTE:** All vent pipes must be glued, properly supported and the exhaust must be pitched a minimum of a 1/4" per foot back to the heater (to allow drainage of condensate). All stainless venting must be sealed at each joint per manufacturer's instructions.

 **CAUTION**

Flue Gas will condense as it exits the vent termination. This condensate can freeze on exterior building surfaces which may cause discoloration of these surfaces. Consideration should be given to the plume of condensation that exits the exhaust which may affect the cosmetic appearance of the building.

C. INLET AIR VENT

You may use the same material as used for exhaust or any material that is the same diameter that provides a pressure tight connection. THIS IS ONLY FOR INLET AIR, NOT FOR EXHAUST PIPING!

The air inlet must be a minimum of 12” vertically above the maximum snow level. It is very important that there are no other vents, chimneys or air inlets in any direction for at least 48”.

All venting must be properly supported. The EVO is not intended to support any venting whatsoever. All piping, glue, solvents, cleaners, fittings and components, must conform to ASTM (American Society for Testing and Materials), and ANSI (American National Standards Institute).

D. VENTING RUNS THAT EXCEED MAXIMUM COMBINED LENGTH

If the combined venting length of a heater’s exhaust/inlet air system exceeds the Maximum Combined Length called out in Table 4-1, Page 15, contact Hamilton Engineering, Inc. for an engineered venting calculation. Do not proceed without calling Hamilton Engineering, Inc. at 800.968.5530 or 734.419.0200.

VENT CALCULATION EXAMPLE: Installation requires the following material for both inlet and exhaust piping for the EVO Micro HW 199.1 (maximum combined equivalent length is 100 feet).

Required: 6 Pcs. 90° elbow (6 x 5 = 30 equivalent feet)	= 30 equivalent feet
Required: 20’ of Plastic PVC Pipe (20 x 1 = 20 equivalent feet)	= 50 equivalent feet
Required: Inlet air in vertical termination (1 + 1 - 90° elbows)	= 11 equivalent feet <i>(includes inlet screen)</i>
Required: Exhaust coupling	= 1 equivalent foot
Total Friction Loss in equivalent feet	= 92 equivalent feet
	THIS VENT SYSTEM IS OK!

 **DANGER**

The EVO is not intended to be common vented with any other existing appliance! Multiple EVO products may be common vented only if using an engineered system by Hamilton Engineering, Inc.

E. HEATER REMOVAL FROM AN EXISTING COMMON VENT SYSTEM

At the time of removal of an existing heater, the following steps shall be followed with each appliance that remains connected to the common venting system placed in operation, while the other appliances that remain connected to common venting system are not operating.

1. Seal any unused openings in the common venting system. The EVO venting is NOT to be combined with this older venting system!
2. Visually inspect the venting system for proper size and horizontal pitch to determine if there is blockage, leakage, corrosion or other deficiencies that could cause an unsafe condition.

3. If practical, close all building doors, windows and all doors between the space in which the appliance remains connected to the common venting system and other spaces in the building. Turn on clothes dryers and any appliances not connected to the common venting system. Turn on any exhaust fans, such as range hoods and bathroom exhausts, at maximum speed. Do not operate a summer exhaust fan. Close all fireplace dampers.
4. Place the appliance being inspected in operation. Follow the lighting instructions. Adjust the thermostat so the appliance will operate continuously.
5. Test for spillage at the draft hood relief opening after 5 minutes of main burner operation. Use the flame of a match or candle or smoke from a cigarette.
6. After it has been determined that each appliance remaining connected to common venting system properly vents when tested as outlined, return doors, windows, exhaust fans, fireplace dampers and any other gas burning appliance to their previous condition of use.
7. Any improper operation of the common venting system should be corrected so the installation conforms with the National Fuel Gas Code, ANSI Z223.1. When resizing any portion of the common venting system, the common venting system should be resized to approach the minimum size as determined using the appropriate tables in Appendix G in the National Fuel Gas Code, ANSI Z 223.1

F. CONDENSATE REQUIREMENTS

This is a condensing high efficiency appliance, therefore this unit has a condensate removal system. Condensate is nothing more than water vapor derived from the combustion products, similar to an automobile when it is initially started. This condensate does have a low pH and should be treated with a Condensate Neutralizer Filter. This filter contains either lime or marble rocks, which will neutralize the condensate. The outlet of the filter is sized for 1.5" PVC pipe. ***It is very important that the condensate line is sloped away from and down to a suitable inside drain.*** A condensate neutralizer and a condensate pump kit are available from Hamilton Engineering, Inc. It is also very important that the condensate line is not exposed to freezing temperatures, or any other type of blockage. Plastic tubing or PVC pipe should be the only materials used for the condensate line. Steel, brass, copper or others will be subject to corrosion and deterioration. A second vent may be necessary to prevent condensate line vacuum lock if a long horizontal run is used. The EVO appliance has an automatic safety device that will shut it down in the event of a condensate drain blockage. Please test annually.

Maximum volume of condensate produced is 11 gallons per hour per 1,000,000 BTU of gas burned.

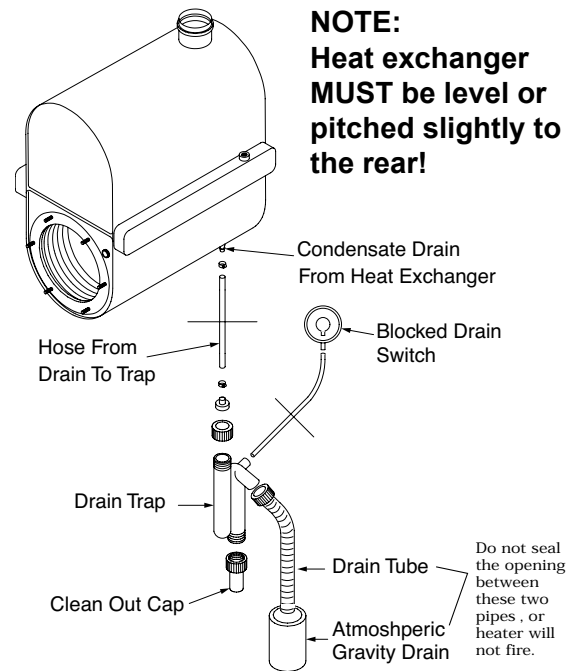

(FIGURE 4-4)
CONDENSATE DRAIN DETAIL

PART 5. PIPING

A. HYDRONIC HEATING BOILER PIPING

The EVO is designed to function in a closed loop (minimum) 12 PSI System. Never let the EVO operate without a minimum of 10 PSI water pressure, this assures that the EVO heat exchanger can be completely purged of air, failure to do so could cause damage. It is important to note that the EVO Boiler is flow dependent for proper efficiency and life expectancy; therefore, primary-secondary piping or use of a low loss header design is always recommended, as shown in the Figure 5-1. Each EVO Heating Boiler System should have an Air Eliminator, in addition to the heat exchanger mounted air vent, which will remove air from the Hydronic System. Always follow good piping practices. Observe minimum 1" clearance to combustibles around all uninsulated hot water pipes,

or when openings around pipes are not protected by non-combustible materials. On an EVO installed above radiation level, some state and local codes require a low water cut off device at the time of installation by the installer. A water flow switch is provided as standard and will take the place of a low water cut-off. If the EVO supplies hot water to heating coils in air handler units, flow control valves or other devices must be installed to prevent gravity circulation of boiler water in the coils during the cooling cycle.

Basic piping connection steps are listed below. A drawing, specific to your application can be obtained from your distributor or Hamilton Engineering, Inc., which will guide you through proper installation of the EVO.

- 1) Pipe properly, in accordance with generally accepted piping principals or Hamilton Engineering specific documents.
- 2) Connect system return to the pipe leaving the EVO closest to the back.
- 3) Connect system supply to the pipe leaving the EVO containing the Relief Valve.
- 4) Install Drain Valve on system supply.

Note: the EVO can not be drained of water without purging the unit with air pressure, 15 PSI minimum. The system's air vent must be closed during this process.

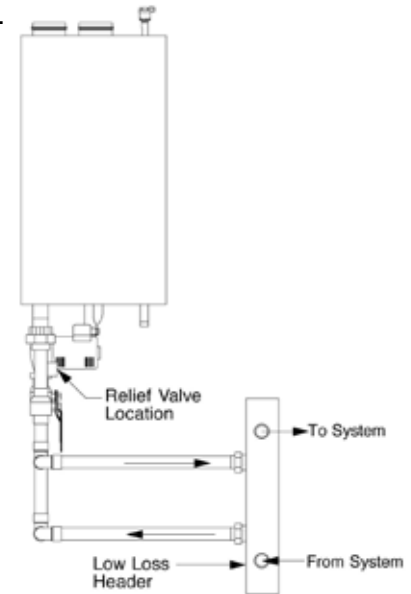

(FIGURE 5-1) BOILER PIPING

B. FILL & PURGE HEATING SYSTEM

- 1) Attach hose to balance and purge hose connector and run to drain.
- 2) Close the other side of the balance and purge valve.
- 3) Open first zone balance and purge valve, so as to let the water flow out of the hose. If zone valves are used, open zone valves one at a time, manually. (NOTE: please check manufacturer's instructions prior to opening valves manually, so as not to damage the valve.)
- 4) Manually operate fill valve regulator. When water runs out of hose, connected to the balance and purge valve, in steady stream (with no air bubbles), close balance and purge valve to stop the water from flowing. Disconnect hose and connect to next zone to be purged.
- 5) Repeat procedure for additional zones (one at a time).

Upon completion, make sure that the fill valve is in automatic position and each zone balance and purge valve is in the open position and zone valves are positioned for automatic operation.

NOTE: Installations that incorporate Standing Iron Radiation and systems with manual vents high points: Follow the above procedure, then starting with nearest manual air vent, open vent until water flows out; close vent. Repeat procedure, working your way toward furthest air vent. It may be necessary to install basket strainer in an older hydronic system where larger amounts of sediment may be present. Annual cleaning of the strainer may be necessary.

C. REMOVING AIR FROM THE HEAT EXCHANGER

The EVO DUO (it is not necessary on an EVO MICRO) has an automatic air vent on the top of the appliance and the air vent cap must be loosened to allow trapped air to escape when the appliance is initially filled and put into operation. If this air vent should start to leak, there are two possible solutions:

- a. Close the cap – the air vent is not needed anymore after the heat exchanger has been purged of air. This air vent **MUST** be operable if the appliance is drained and refilled.
- b. Replace the air vent. When replacing the air vent, the water must be shut off and pressure released first.

PIPING

D. WATER HEATING PIPING

- 1) Use only the pipe sizes shown and a pump meeting the listed specifications in the following tables:
*Note: Individual Appliance Piping pressure drop used in the tables is based on 20 feet of straight pipe, 6 elbows, 2 tees, 2 full port ball valves and 2 unions.
- 2) The cold water supply to the water heating system should be connected between the heater outlet and the storage tank or the storage tank directly. This will help minimize unnecessary short cycling due to small hot water draws.
- 3) Isolation valves should be installed on each heater and on the cold and hot water system connections.

Upon completion of piping, fill and properly purge of all air. Open all valves and start circulating pump. Consult Hamilton Engineering for specific piping diagrams for your application at 800.968.5530.

NOTE: Minimum pump selection is based on piping sizes shown above and water hardness not to exceed 15 grains per gallon and total maximum equivalent piping length of 60 feet.)

(FIGURE 5-2) HEATER PIPING

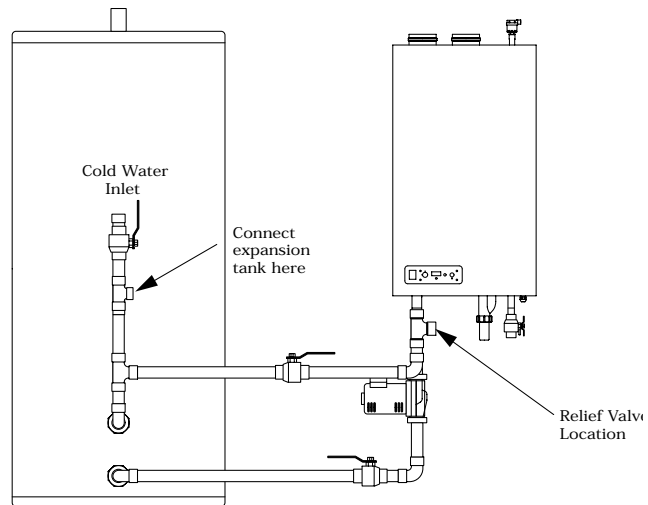

WATER HEATER

Model	*GPM ΔP	Design ΔT		Pump Supplied	Minimum manifold pipe size			
		°F	°C		Single	Double	Triple	Quad
HW 79	6.6 @ 19.9'	23.5°F	13.1°C	PMP 30213	1"	1"	1.5"	1.5"
HW 129	6.6 @ 19.9'	40.1°F	22.2°C	PMP 30213	1"	1"	1.5"	1.5"
HW 179	9.9 @ 21.8'	36.6°F	20.3°C	PMP 30213	1"	1.5"	1.5"	2"
HW199.1	9.9 @ 21.8'	39.2°F	21.8°C	PMP 30209	1"	1.5"	1.5"	2"
HW299	16.5 @ 22.9'	35.3°F	19.6°C	PMP 30209	1.5"	2"	2"	2.5"
HW399	26.4 @ 20.3'	29.4°F	16.3°C	PMP 30209	2"	2"	2.5"	3"
HW599	39.6 @ 23.6'	30.9°F	17.1°C	PMP 30229	2"	2.5"	3"	4"

*Water heater and piping as described above

BOILER

Model	Boiler Only GPM P	Design T		Pump Supplied	Minimum manifold pipe size			
		°F	°C		Single	Double	Triple	Quad
HW 79	4.4 @ 7.9'	34.6°F	19.2°C	PMP 30213	1"	1"	1"	1.5"
HW 129	4.4 @ 7.9'	58.9°F	32.7°C	PMP 30213	1"	1"	1"	1.5"
HW 179	6.6 @ 7.9'	53.7°F	29.8°C	PMP 30213	1"	1"	1.5"	1.5"
HW199.1	6.6 @ 7.9'	57.6°F	32.0°C	PMP 30213	1"	1"	1.5"	1.5"
HW299	11 @ 9.3'	51.8°F	28.8°C	PMP 30209	1.5"	1.5"	2"	2"
HW399	17.6 @ 8.5'	43.2°F	24.0°C	PMP 30209	1.5"	2"	2"	2.5"
HW599	26.4 @ 9.4'	45.3°F	25.2°C	PMP 30229	1.5"	2"	2.5"	3"

PART 6. START-UP PROCEDURES

A. ITEMS TO BE CHECKED BEFORE LIGHTING THE EVO

It is recommended that you read the General Information Section (Part 1, Page 4) to get a better understanding of how the EVO operates before you start the unit.

1. Make sure that you follow the lighting instructions before running the EVO.
2. Check and make sure the circulating pump is running, and that the Flow Switch is operating correctly (Page 29).
3. Make sure that the Gas is turned on outside the bottom of the cabinet of the EVO.
4. Double check to be sure the temperature setting is correct.
5. Make sure the unit is properly grounded and the electrical wiring meets the requirements of the Electrical section (Part 2, Page 8).
6. Make sure that no valves are placed between the relief valve and the appliance. The relief valve must be installed in such a manner that the discharge will be conducted to a suitable place for disposal when relief occurs. Ensure that no reducing coupling or other restriction is installed in the discharge line, and that the discharge line is installed to allow complete drainage of both the valve and the line.
7. Turn on the power to the EVO. The Setpoint Temperature of the EVO will appear in the display at this time. If a fault code appears, correct the fault before operating. The EVO will now run its pre-purge and ignition cycles, then begin heating, which will be indicated by the green "BURNER ON" light.



WARNING

If you do not follow these instructions exactly, a fire or explosion may result, causing property damage, personal injury, or loss of life.

B. LIGHTING INSTRUCTIONS

FOR YOUR OWN SAFETY, READ BEFORE OPERATING!

1. This appliance does not have a pilot light. It is equipped with an ignition device which automatically lights the burner. Do not try to light the burner by hand.
2. BEFORE OPERATING smell all around the appliance area for gas. Be sure to smell next to the floor because some gas is heavier than air and will settle on the floor.

WHAT TO DO IF YOU SMELL GAS

- Do not try to light any appliance.
 - Do not touch any electric switch; do not use any phone in your building.
 - Immediately call your gas supplier from a neighbor's phone. Follow the gas suppliers' instructions.
 - If you cannot reach your gas supplier, call the fire department.
3. Turn on gas shutoff valve (located outside the cabinet on the bottom of the appliance) so that the handle is aligned with the gas pipe. If the handle will not turn by hand, don't try to repair it; call a qualified service technician. Force or attempted repair may result in a fire or explosion.
 4. Do not use this appliance if any part has been under water. Immediately call a qualified service technician to inspect the appliance and to replace any part of the control system and any gas control which has been under water.
 5. The EVO Heater shall be installed so the gas ignition system components are protected from water (dripping, spraying, rain, etc.) during appliance operation and service (circulator replacement, condensate trap, control replacement, etc.).

C. OPERATING INSTRUCTIONS

1. STOP! Make sure you have read the safety information above.
2. Turn off all electric power to the appliance.
3. This appliance is equipped with an ignition device which automatically lights the burner. Do not try to light the burner by hand.
4. Turn gas shutoff valve clockwise to "off" The handle will be horizontal; do not force it.
5. Wait five (5) minutes to clear out any gas. If you then smell gas, STOP! Follow the instructions from Section B: Lighting Instructions in the safety information. If you don't smell gas, go to the next step.
6. Turn the gas shutoff valve counter clockwise to "on" The handle will be vertical.
7. Turn on all electric power to appliance.
8. Set the thermostat to the desired setting.
9. If the appliance will not operate, follow the instructions "To Turn Off Gas To Appliance" Section F, Page 31 and call your service technician or gas supplier.

D. ADJUSTING THE TEMPERATURE ON THE EVO DISPLAY

The red knob labeled Setpoint is used to set the desired operating water temperature. On a boiler, this will be based on the leaving water temperature. On a water heater it will be based either on a connected external (storage tank) sensor, or, if there is none connected, it will operate based on the incoming water temperature. There are no temperature markings on the knob itself, as the range of this knob is factory-set at 50–159°F for water heaters and 50–192°F for boilers. Other special ranges are available by contacting the factory. Any movement of the knob will be immediately indicated on the temperature display when the appliance is powered on. ***If other temperature settings are required, contact Hamilton Engineering, Inc.*** This is the only function able to be set by the end-user; all others are set by a special computer program at the factory, or while in service mode. The display can show either °F or °C as factory-set. Display will indicate "0" when temperature setpoint is reached.

E. SEQUENCE OF OPERATION

**DANGER****▲ DANGER**

Water temperature over 125°F can cause several burns instantly, or death from scalds. Children, the disabled, and the elderly are a highest risk of being scalded. See instruction manual before setting temperature at water heater. Feel water before bathing or showering! Temperature limiting valves are available.

▲ DANGER

1. When power is first applied to the control, the control display will read the temperature Setpoint. The control will initially run through a self-diagnostic routine and then go into its operating mode. If there is no call for heat, the system will go into an idle state.
2. If the thermostat is calling for heat, the control module will determine if the water temperature is below the programmed set point value minus the switching differential. It will then initiate a heating cycle.
3. The control then performs selected system diagnostic checks. If all checks are successfully passed, a pre-purge cycle is initiated (the blower will be on maximum speed).
4. When the pre-purge period is complete, power is applied to the spark ignitor for 4.5 seconds. Approximately 1/2 second later, flame is verified. If a flame is not verified during the trial-for-ignition, the gas valve is immediately closed and the control will return to Step 3. After four trials, if a flame is not verified, the control will go into a lockout mode. If a flame is confirmed, the control enters the heating mode. The firing rate will be based on the control's proprietary algorithm.
5. When water temperature reaches the temperature set point value, the burner will be at minimum firing rate. If, when firing at minimum rate, it reaches 3°F over temperature setpoint, the gas valve closes and the control enters a post-purge state (the blower will be on maximum speed). At any time if an external thermostat is being used and becomes satisfied, the gas valve will be closed immediately and display will read "0".
6. When the post-purge is complete, the control enters an idle state while continuing to monitor temperature and the state of other system devices. If a call-for-heat is received, the control will automatically return to Step 2 in sequence and repeat the entire operating cycle.
7. Built in freeze protection: all models will automatically turn the pump on if the heat exchanger reaches 41°F and the burner if it reaches 37°F, it will turn off at 50°F.

Note: power must be left on for this protection to function.

During the idle state and heat state, if the control detects an improper operating state from external devices, such as the high-limit switch, the control will illuminate an error code in the display.

PART 7. SERVICING

A. SERVICING THE EVO

1. Shut off the power supply to the appliance (See Figure 1-4, Page 7).
2. Remove the front cover security screw(s).
3. Undo the two latches at the bottom of the cover (if applicable).
4. Remove the cover.

B. PLACING THE EVO INTO NORMAL OPERATION

1. Replace the front cover in the normal position.
2. Close the latches on the bottom of the cabinet (if applicable).
3. Replace the security screw(s).
4. Turn on the power supply to the appliance.

C. SOFT LOCKOUT CODES

(TABLE 7-1) FMT 914 SOFT LOCKOUT CODES

DESCRIPTION	DISPLAY CODE	WILL AUTOMATICALLY RESET WHEN:
Low water cut off (if equipped) opened	A1	The water level is restored
Manual reset high limit or low gas pressure switch (if equipped) opened	A1	Must reset manually on safety control
Outlet temperature too high	A2	Outlet temp decreases sufficiently
External sensor temperature too high	A3	The temp decreases sufficiently
Indirect DHW temperature too high	A4	DHW temp decreases sufficiently
Too many on off cycles	A5	After control keeps appliance off for two minutes
Fan speed too high	A6	Fan speed is OK within 1 minute. If not, it will become a Hard Lock Out
Fan speed too low	A7	Fan speed is OK within 1 minute. If not, it will become a Hard Lock Out
Anti-scale setting exceeded	A8	The temp is less than the setting
Flame simulation	C1	No flame is measured

If the appliance is shut down for any reason other than the operating setpoint, a Soft Lockout Code is displayed in the Temperature Display. If the Code is not flashing, the codes reference the above information.

Note: F2 will equal improper gas pressure on a CSD-1 equipped model.

D. HARD LOCKOUT CODES

(TABLE 7-2) FMT 914 SOFT LOCKOUT CODES

DESCRIPTION	DISPLAY CODE	ACTION TO RESET
Flame signal without flame	F0	Reset button
Wrong fan speed indicated	F4	Reset button
No flame after 4 tried for ignition	F5	Reset button
Flame lost (4 times) during a burn cycle	F6	Reset button
Outlet sensor short/interrupted	E0	Reset button
Inlet sensor short/interrupted	E2	Reset button
External sensor short/interrupted	E5	Reset button
Anti-scale setting exceeded 3 times during burn cycle	E6	Reset button
Parameters programmed	PP	Reset button
Parameters programmed incorrectly	PE	Reset button
FMT 914 burner controller is out of order	Nc	Re-program / Disconnect power
Water flow switch, pressure switch, or the High Limit opened	H1	Reset button
No lag control is communicating in Cascade	nc. (with dot)	Restore RS-485 Wiring

If the appliance is shut down for any reason other than the operating setpoint and there is a Fault Code displayed in the Temperature Display and the display *is flashing* a Code, the code references the above information.

IN MANY CASES, A “HARD LOCKOUT” WILL INDICATE THAT THERE IS SOMETHING WRONG WITH THE APPLIANCE, THAT SHOULD BE SERVICED OR REPAIRED.

EXAMPLE:

If there is a loss of flow due to an air bubble passing through the appliance (sensed via the water flow switch), the appliance will shut down and display a temporary fault (H1). When flow resumes and the reset button pushed, the control board will perform a pre-start diagnostic and then resume a burn cycle.

(TABLE 7-3) REFERENCE OF SOLUTIONS FOR HARD LOCKOUT CODES

MEANING OF LOCKOUT	DISPLAY CODE	POSSIBLE CAUSE OF LOCKOUT
Short circuit in flame signal (ionization) circuit	F0	18, 35 61
Water flow switch, high limit temperature or pressure switch has opened	H1	4, 5, 21, 22, 23, 29, 30, 42, 67, 68
Wrong fan speed	F4	7, 8, 9, 13, 39, 40, 41
No flame after 4 ignition attempts	F5	10, 11, 12, 16, 18, 25, 35
Flame lost (4 times) during a single burn cycle	F6	10, 12, 16, 22, 25, 26, 44
Outlet sensor shorted or interrupted	E0	46, 71
Inlet sensor shorted or interrupted	E2	46,71
External sensor shorted or interrupted	E5	46, 51, 55, 63
Too many anti-scale lockouts	E6	4, 5, 28, 29, 72, 73
Parameter programmed	PP	Press reset button
Parameter programmed incorrectly	PE	Program one more (Com1 or Com2)
Burner control is not functioning correctly	Nc	Press reset button
No communication within the Cascade control system	nc. (with dot)	Bus cable not correctly wired or wrong COM port

Beside the above lockouts, there are several faults or complaints the display is unable to convey.

(TABLE 7-4) ADDITIONAL COMPLAINTS FOR HARD LOCKOUTS

	COMPLAINT	CAUSE OF FAULT
a.	The building is not warming up or water is not getting hot, but appliance is working	31, 45, 53, 54
b.	Noisy ignition	16, 35
c.	Room thermostat or external thermostat demanding heat, but appliance is not firing	1, 42, 52
d.	Appliance is very noisy during operation	29, 46, 66
e.	Tops of radiators are insufficiently hot	5, 55
f.	Temperature of the DHW is far too hot	51, 57
g.	Fault after replacement of the burner control	60

E. FAULT CAUSES

The numbers given in Tables 7-3 and 7-4 match with those in the following table to give the reason for the fault.

(TABLE 7-5) FAULT CAUSES

1.	Room thermostat
4.	Pump not running or partially clogged
5.	Water pressure in the system too low (heat exchanger/radiator air bound)
7.	Fan speed control wiring not connected (unplugged)
8.	Fan blades are fouled - check for lint or dirt build-up on blades
9.	Fan is defective
10.	Manual gas valve under heater not open
11.	Gas pressure is too low
12.	Gas pipe diameter is too small
13.	Fuse blown - replace with 3.15 amp only
16.	Gas valve setting for low fire is incorrect (the offset setting)
18.	Ignition cable incorrectly connected
21.	Power supply to the pump connected incorrectly
22.	Condensate trap is plugged or drain line is blocked
23.	Air bubble in heat exchanger - open air vent cap
25.	Too much resistance in the flue system, or flue system has been restricted
26.	Flue system incorrectly installed, allowing re-circulation of flue gas
28.	Water piping shut off valve partially closed
29.	Heat exchanger blocked (insufficient circulation)
30.	High-limit thermostat defective (contacts corroded)
31.	Maximum load is too high
35.	Ignition electrode porcelain is cracked or spark gaps are incorrect
39.	Moisture in the fan and/or the fan connection
40.	Fan wiring plus for speed control (PWM) signal connected incorrectly
41.	Fan wiring plug for 230 VAC power supply connected incorrectly
42.	Damaged connecting cable to high limit sensor
44.	The built-in non-return valve in the flue is partially blocked
45.	Leak in hot water piping
46.	Sensor defective; compare ohm reading to actual temp (see Figure 7-1 on page 32)
51.	Parameter(s) in the installer program entered incorrectly
52.	Room thermostat (or common thermostat) connected to an incorrect connector strip port
53.	Pulse with program in the installer menu incorrectly programmed, or steps are too long
54.	Clock program of the dock thermostat should start earlier in the morning
55.	Flow and return line on the boiler have been changed around
57.	Priority sensor (S3) not placed correctly, or is defective
60.	Cable harness connectors incorrectly mounted on the PCB
61.	Gas valve is defective
63.	Incorrect parameters or values outside the range of the program have been entered

(TABLE 7-5) FAULT CAUSES (CONTINUED)

66.	Gas valve not correctly adjusted at maximum load
67.	Venting system has too much resistance (possibly partially blocked)
68.	Setting of the pressure switch is incorrect (setting = 7mbar)
70.	Electrical contacts are corroded
71.	Wiring to switch is disconnected or incorrectly connected
72.	Insufficient flow through the boiler
73.	Heat exchanger is beginning to accumulate scale

The numbers given in Tables 7-3 and 7-4 match with those in the following table to troubleshoot.

(TABLE 7-6) TROUBLESHOOTING THE FAULT

1.	Flow and return line on the boiler have been changed around
4.	Try to loosen the pump spindle, or replace the pump drive
5.	Check available city water pressure - water heater must be over 15 PSI. Boiler closed loop heater system must have at least 12 PSI from fill valve. Check operation of expansion tank.
7.	Remove and reconnect the wiring harness, being sure that the plus lines up properly and latches when fully inserted
8.	Clean the fan blades
9.	Replace the fan - <i>see notes below under 13</i>
10.	Open gas valve
11.	Check line, gas meter, and pressure to heater inlet (it must be at least 4 inches WC). Make a pressure drop test and calculation, as required.
12.	Change gas lines. If a flexible connector is used, it must be rated for the BTU capacity of the appliance. CONNECTORS PURCHASED AT HOME CENTERS WILL NOT WORK!
13.	Replace fuse. Check the fan; moisture will short circuit across the plug or wiring. The fan should run at maximum speed by undoing the fan plug (speed control) with the 4 wires. If it does not, replace the fan. If it does, check the wiring harness and connections.
16.	See pages 11-13
18.	Check cable and cap for shorting to ground, overheating, and cut or worn cable casing. Check spark ignitor porcelain for cracks. Check for 3/8" gap at electrodes.
21.	Check that the plug(s) are fitting tightly
22.	Open the condensate trap and clean out (underneath the appliance in the center) by unscrewing the cap. Keep a jug on hand to catch the water drained. Look through the drained material for contaminants. If there are alot, take the burner unit from the appliance as required, and pour some water in the heat exchanger to rinse out the drain line
23.	Bleed all air from not only the appliance itself, but the entire system. If working on a closed loop heating system, take care not to run the pumps if there is no water
25.	Check the inlet air and flue lines for blockage
26.	Check the inlet and flue system starting at the appliance outlet
28.	Check all shut off valves and check valves. Be sure they are fully open.

(TABLE 7-6) TROUBLESHOOTING THE FAULT (CONTINUED)

29.	First check that the pump is circulating like it should, that there are no obstacles between the appliance and the tank (or in any of the inlet/outlet piping), and that the appliance is still making noise. Then the heat exchanger will need to be acid cleaned. DO NOT RUN THE APPLIANCE UNTIL THIS IS DONE!
30.	Replace the high-limit thermostat by unscrewing it from the brass nut; no draining is needed (do not remove the brass nut)
31.	Go over the Fan RPM settings as outlined in Table 3-4 on page 12-13
35.	Replace. Or when bending, take care: bend near the burner plate, or there may be risk of cracking
39.	Remove the connection and blow dry using a hair dryer or compressed air
40.	The plug wire connection must point to the outside of the fan. One side should fit into the groove on the PCB
41.	Check the plugs and fit into one another correctly
42.	Check cables for possible damage or entrapment, and replace as required
44.	Check the seal of the heat exchanger on the flue gas casing, and replace as required. Fit a new rotary lip seal. Lift the flue gas tube and inspect the Non-Return Valve from the top
45.	Check the flow and DHW lines
46.	Disconnect leads from sensor and place an OHM meter across both terminals on the sensor. Compare to Figure 7-1 on page 32. If it does not match, replace
51.	Contact Hamilton Engineering for assistance at 800.968.5530
52.	Check the type of room thermostat and contact Hamilton Engineering for assistance at 800.968.5530
53.	Contact Hamilton Engineering for assistance at 800.968.5530
54.	Change the “wake-up” times of the clock thermostat
57.	Check the sensor on the storage tank or in the common piping
60.	It may occur that the 18-pin FMT 914 plug moved up one pin too far—this may cause a fault in the communication between the wiring and the pins. Check both the left and the right-hand side of the plugs to ensure they are placed correctly
61.	A defective gas valve usually has one of the two causes: the electric coils are defective, or an internal defect to the gas valve. In either case, it is recommended to replace the entire gas valve
63.	Contact Hamilton Engineering for assistance at 800.968.5530
66.	Re-adjust the gas valve per the instructions on pages 11-12
67.	Check the venting system completely for blockage
68.	If the setting is correct and all possible causes of blocked flue or condensate drain system have been eliminated, replace the pressure switch
69.	When there is water in the tube, there must be a leakage by one of the connections (air can escape through this leak), and inspect the tube for small cracks. Replace the plastic tube as needed.

(TABLE 7-6) TROUBLESHOOTING THE FAULT (CONTINUED)

70.	Replace the part; it cannot be repaired
71.	Check the wiring
71.	Check the entire system including the pump for blockage and scaling
71.	For descaling, see the special instructions. Contact Hamilton Engineering for assistance at 800.968.5530

F. TO TURN OFF GAS TO THE APPLIANCE

- 1) Set the thermostat to lowest setting.
- 2) Turn off power switch on front of unit.
- 3) Turn off all electric power to the appliance if service is to be performed.
- 4) Turn gas shutoff valve clockwise to “off.” Handle will be horizontal. Do not force.

G. PUMP & WIRING CONTROL

The FMT 914 control board has an on-board relay for controlling the circulating pump. On a call for heat, the pump will start, allowing the water flow switch circuit to be made and the pre-start diagnostic to continue. After the call for heat has been satisfied, the pump will continue to run for the factory programmed period of time (1 minute) and then shut off. For water heating applications an external temperature sensor must be mounted in the water storage tank if the intermittent pump operation is used. For heating applications the call for heat must come from an external source (room thermostat etc.). In both applications if a continuous pump operation is desired, it may be specially factory programmed for that or the pump should be wired directly to an external power supply.

The only restriction is the amount of pump electrical load that can be connected. The maximum wattage an externally connected pump can draw is 650 watts. All standard pumps as supplied by Hamilton Engineering draw 550 watts or less.

The EVO control system has the ability to control up to three (3) or two (2) pumps and a diverting valve. For details see EVO Configurations Manual (LIT91110) or contact Hamilton Engineering at 800.968.5530.

H. TEMPERATURE SENSOR READING INSTRUCTIONS

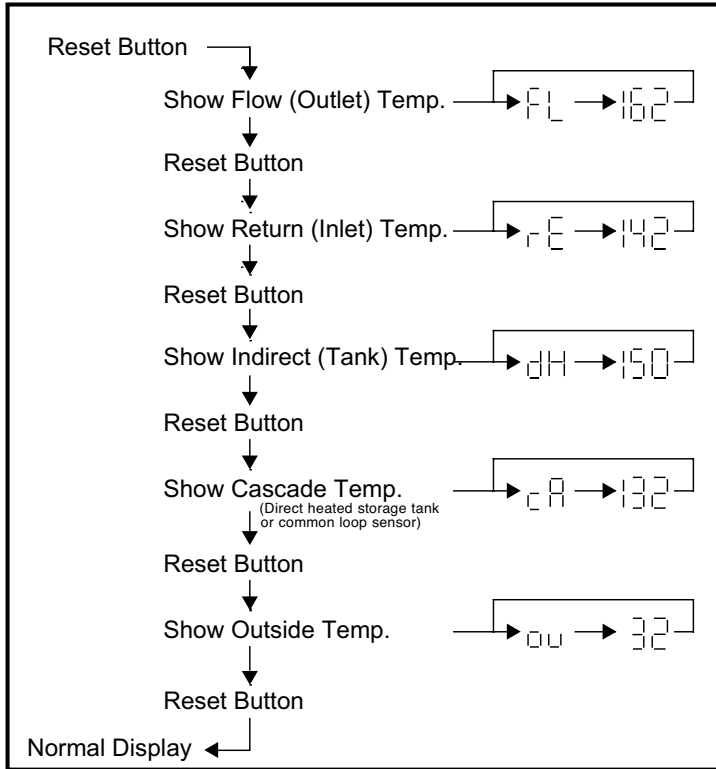

(FIGURE 7-1) TEMPERATURE SENSOR READING INSTRUCTIONS

I. EVO SENSOR RESISTANCE TABLE

(TABLE 7-7) EVO SENSOR RESISTANCE TABLE

TEMPERATURE (°F)	RESISTANCE (OHM)	TEMPERATURE (°C)	RESISTANCE (OHM)
32	32550	0	32550
41	25340	5	25340
50	19870	10	19870
59	15700	15	15700
68	12490	20	12490
77	10000	25	10000
86	8059	30	8059
95	6535	35	6535
104	5330	40	5330
113	4372	45	4372
122	3605	50	3605
131	2989	55	2989
140	2490	60	2490
149	2084	65	2084
158	1753	70	1753
167	1481	75	1481
176	1256	80	1256
185	1070	85	1070
194	915	90	915
203	786	95	786

PART 8. MAINTENANCE

A. MAINTENANCE PROCEDURES

Once a year, a qualified service technician should perform maintenance on your EVO equipment to ensure that everything is operating safely and efficiently. The owner can make necessary arrangements with a qualified heating contractor for proper maintenance of the heater. The equipment installer must also make clear to the owner that the lack of proper care and maintenance of the heater may result in a hazardous condition. The installer should discuss the contents of the User's Information Manual with the owner.

B. ANNUAL INSPECTION

An inspection should cover at least the following areas.

Caution : Before removing the door of the appliance, switch off the electrical power supply to it.

- a. Remove the front cover and check all pipes, lines and connections, heat exchanger (top, bottom) for traces of water and water leakage.
- b. Inspect the top of the casing and/or the top of the appliance for water leakage or traces of water from the air supply pipe or the air vent.
- c. Open the condensate drain cleanout and remove any dirt. Flush and replace.
- d. If the inspection is being carried out by a Hamilton Engineering Certified Technician, connect your computer and check the service page for error messages, starts and failed/successful starting efforts.
- e. Dismantle the burner unit: remove the (6) 6mm nuts and the ignition cable, and move the burner unit forward. Remove the plug of the fan cable to the fan once the burner has been pulled halfway from the appliance. Check the inside of the heat exchanger: only clean residue at the bottom side of the heat exchanger coil. Use a vacuum cleaner, and do not push the residue between the openings of the coils if at all possible as this may impede the flow of the products of combustion. It is possible to use clear water to rinse any remaining residue away – the water will automatically flow to the condensate drain point.
- f. Dismantle the air gas mixing plate or chamber on the suction side of the fan; check the blade wheel of the fan, and clean if required.
- g. Check the distance from the electrode to the burner; there should be a 3/8" gap in between the two. If the existing electrode pins must be adjusted, caution must be exercised as they will likely be brittle from exposure to the flame; try to bend them as close to the burner door insulation as possible. New electrodes will be less susceptible to breakage during adjustment.

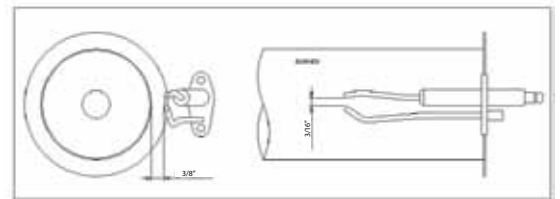

(FIGURE 8-1) DISTANCE FROM ELECTRODE TO BURNER

The following steps require the power supply be turned back on; extreme caution must be exercised when performing service with the power supply on and the door off.

- h. Fire the appliance on maximum output, and measure and adjust the CO₂ percentage as required.
- i. Fire the appliance on minimum output, and measure and adjust the CO₂ percentage as required. See Table 3-3, Page 12 for specific settings.
- j. Listen for any unusual noise in the circulating pump and the fan.

All findings and concerns should be discussed with the appliance owner after the inspection is complete.

⚠ DANGER

It is extremely important to make sure the exhaust vent is no longer blocked. Failure to do so may result in personal injury or death.

C. CONDENSATE TRAP CLEANING INSTRUCTIONS

The condensate trap should be cleaned at least once every year.

- 1) Turn off the power to the EVO.
- 2) Place a bucket under the condensate trap.
- 3) Remove the condensate clean-out cap. Use caution when removing the clean-out cap, as the trap is full of condensate and it may be hot.
- 4) Rinse out the clean-out cap in a sink to remove any dirt or buildup that may have accumulated.
- 5) Reinstall the clean-out cap on the condensate trap.
- 6) Turn on the power to the EVO.
- 7) Monitor the condensate drain until flow has been established.

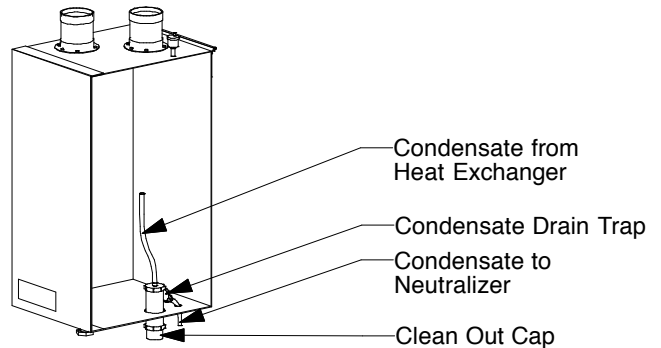

(FIGURE 8-2) EVO CONDENSATE TRAP CLEANING

D. COMBUSTION CHAMBER COIL CLEANING INSTRUCTIONS*

****Before beginning this procedure, you must have the following items on hand:***

- A Nylon brush - DO NOT use brass, stainless or steel brushes.
 - Water
 - Shop vacuum
- 1) Shut down the EVO by using the following steps:
 - a. Turn off the power, close the gas valve, and shut down the unit. Wait for the unit to be cool to the touch.
 - b. Remove the clean-out cap according to the directions above.
 - c. Remove the molex plugs from the fan.
 - d. Remove the (6) 6mm nuts from the burner plate assembly to access the coils.
 - e. Pull the entire burner plate assembly towards you and protect or remove rear target wall.
 - 2) Vacuum all loose material, then use the nylon brush to scrub coils to remove any buildup, then vacuum the debris from the coils.
 - 3) Spray the coils with clear water, making sure to confine the spray to the area being cleaned (try to avoid getting the back ceramic (target) wall of the unit wet). Flush the combustion chamber with fresh water. At this point, the EVO should be ready to power back up.
 - 4) Before powering up the EVO follow the steps below
 - a. Re-install the burner assembly and rear target wall (ceramic insulation)
 - b. Replace the (6) 6mm nuts to the burner plate.
 - c. Re-connect the molex plugs.
 - d. Re-set thermostats.
 - e. Replace the clean-out cap.

- f. Turn the EVO back on** and monitor the condensate drain until flow has been established.
- g. Re-connect the condensate hose to the outside connection.

****NOTE: When firing up the boiler for the first few times you may experience some fluttering of the gas burner that may result in a flame lockout. This is normal and will require you to re-cycle the unit until this clears up. This is caused by water still present in the combustion chamber.**

E. EVO CONTROLS

⚠ DANGER

It is extremely important that you check for leaks when reconnecting the gas valve and make sure the exhaust vent is no longer blocked. Failure to do so may result in severe personal injury or death.

The following components are found on the control panel on the front of the appliance.

(FIGURE 8-3) EVO CONTROL PANEL

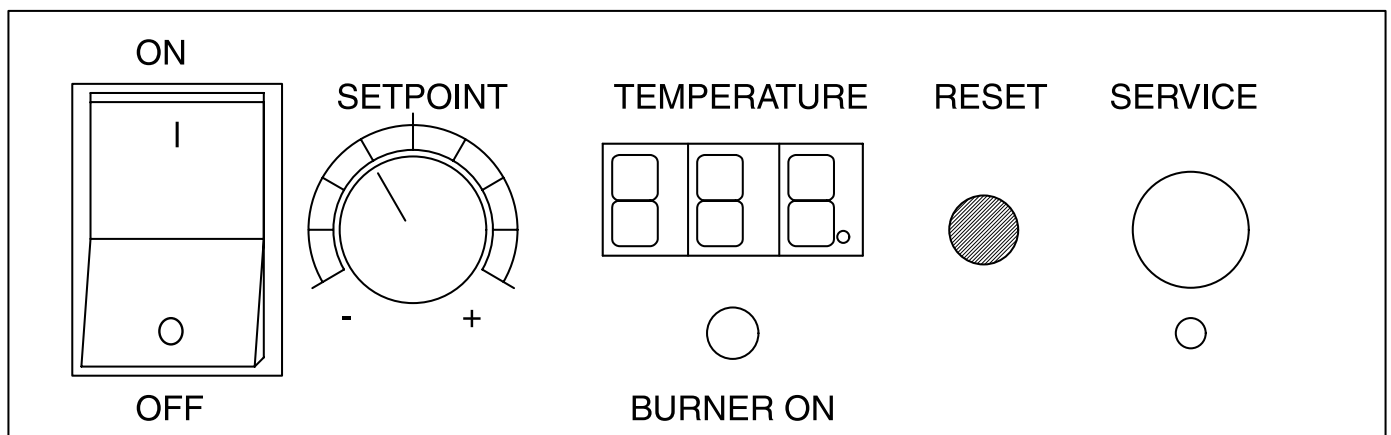

Looking at the controls on the front of the appliance,

- 1) POWER on/off switch
- 2) SETPOINT knob, temperature control (and fan speed control knob during service mode)
- 3) TEMPERATURE setpoint display
 - a. Temperature in °F, corresponding to the SETPOINT knob
 - b. Display will always read temperature setpoint unless there is a fault code displayed.
 - c. Cascade indicator light, found in the lower right hand corner of the Temperature display. This dot will be flashing when this appliance is part of a properly-connected, commonly-controlled group of EVO products and reading temperature sensors.
 - d. Display code, not flashing indicates a Soft Lockout
 - e. When this display is flashing a code, the appliance is in a Hard Lockout and the reset must be pushed to re-start the appliance.
- 4) Green indicating light labeled BURNER ON; when this light is on, the burner is firing.
- 5) RESET button, used as described in 3e above, as well as to view sensors and set altitude (see pages 32 & 36 for details).
- 6) SERVICE port, used for connecting a computer to the appliance to download the service fault history, as well as factory setting of control board parameters. There is a service button located just below the service port that must be pressed with a pointed object to get to the service mode.

The appliance's primary controller (FMT 914) operates all functions of needed control and safety. It contains sophisticated logic that allows it to operate at very precise temperatures while minimizing burner on/off cycling. When multiple units are operated as a Cascade to handle a common load, the control contains the ability to control all of the units as efficiently as one. Cascade operation is a factory-installed and programmed option, requiring a field wiring connection between appliances for operation. A number of parameters must be programmed at the factory to provide proper operation and temperature control, including Controlling sensor; Setpoint, Offset, Hysterisis and bandwidth. Secondary sensor; Setpoint & Offset.

- **Setpoint:** desired operating water temperature (this is set by the end user)
- **Offset:** amount the temperature is allowed to go above Setpoint before finally shutting off
- **Hysterisis:** amount the temperature is allowed to drop under Setpoint plus offset before the appliance turns on
- **Bandwidth:** the range over which flame modulation occurs (this only takes place below Setpoint)

F. INSTALLATION AT HIGH ALTITUDES

This appliance is equipped with an automatic combustion characteristic adjustment system, provided the installed elevation above sea level is entered into the operating control (FMT 914) when the height is greater than 2,000 feet and less than or equal to 9,000 feet. To enter the operating elevation:

- Press the **reset button** continuously for 3 seconds, the appliance shows the adjusted altitude of the appliance (0 = sea level). Each time the **service button** is pressed, the value increases by 100 feet (20 through 90 = 2,000 through 9,000 feet). After reaching the maximum value, the counter returns to the minimum value (example: when the value is 90 and the service button is pressed, the new value will be 20). When the right altitude has been set (example: 53 = 5,300 feet of elevation above sea level), press the **reset button** for one second and the value will be programmed. The factory default is 20 (which equals 2,000 feet), and there is no need to adjust below that. **See Figure 8-3 for the button locations.**
- The adjusted altitude entered is internally converted to an offset on top of the maximum fan speed.
- ***By adjusting the combustion characteristics as described above, there is no de-rate required at altitudes up to 9,000 feet. For elevations in excess of 9,000 feet or gas BTU content levels below 950 BTU/cubic foot, consult the factory at 734.419.0200 or 800.968.5530 for adjustments and de-rating information.***

G. COIL ANTI-SCALING PREVENTION FEATURE

The EVO controller (FMT 914) contains sophisticated software that enables it to monitor the rate of temperature rise through the heat exchanger. By doing this, it greatly reduces the possibility of heat exchanger failure due to scaling or fouling. A set of parameters are programmed in at the factory, to provide a design temperature rise (ΔT) setting on each size unit that is fixed. The Anti-Scale is based on an increase over the design ΔT through the heat exchanger. This Anti-Scale is determined using the inlet and outlet sensors, even if a tank thermistor is being used. If the Anti-Scale setting is reached, the unit will display A8, shut down and not re-fire until it has cooled. After the first three times this condition is reached in the FMT 914 reset life cycle (reset life cycle is the time between factory service history downloads), the FMT 914 control will go into hard Lockout, display E6, and have to be manually reset. After it has been reset, it will fire again, but at a maximum of 50% of rated input in an attempt to prevent further damage but still provide some hot water. Once the heat exchanger has been acid cleaned contact the factory for instructions on resetting the unit for full rated BTU input.

Typical causes for repeated E6 indications at start up are air trapped in the heat exchanger (be sure air vent cap is loose) or contaminates lodging in the piping or heat exchanger during installation, both of these causes can generally be cleared by isolating the hot water system and flushing water at full city pressure through the drain valve or relief valve on the heater outlet.

Please note: Scale monitoring feature only available on HWD (water heater) models.

H. WATER HEATER OPERATING SAMPLE

All of the following parameters are controlled by either a storage tank temperature sensor or the inlet temperature sensor:

- **Setpoint** = Target Temperature (120°F) Low fire only above this point
- **Offset** = Off Setpoint (3) = 123°F off
- **Hysterisis** = On Setpoint (8) ($120 + 3 - 8 = 115^{\circ}\text{F}$)
- **Bandwidth** = Modulation range (4) ($120 - 4 = 116^{\circ}\text{F}$, modulation begins)

The heater turns on at 115°F and when the temperature reaches 116°F the flame will begin to modulate down (approximately 25% of the modulation range per degree F of increase in this example) at 120°F, it will be at low fire and will remain there unless the temperature drops below 120°F and it will modulate back up. If it continues to increase, it will shut down at 123°F.

Outlet sensor

Its purpose is twofold: first stage high limit and second as a sensor for computing ΔT . Default water heater settings are as follows:

- **Setpoint** = start of modulation (185°F)
- **Offset** = Off Setpoint (5°F) ($185 + 5 = 190^{\circ}\text{F}$ off)
- There is a fixed **Manual Reset High Limit** at 195°F on water heaters, and 225°F on heating boilers.

I. EVO MICRO (HW 79-199.1 & 199.8) PARTS BREAKDOWN

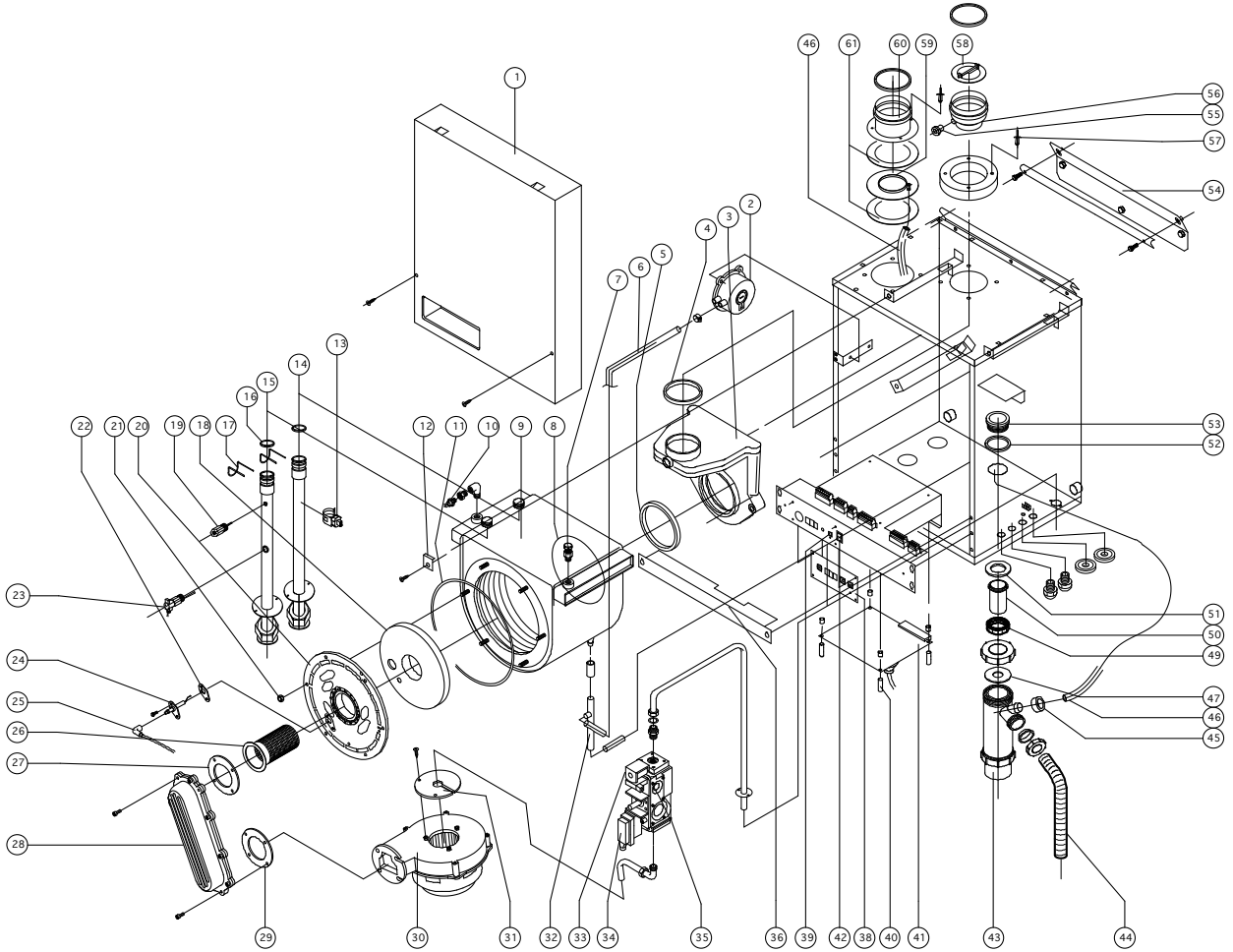

NUMBER ON DRAWING	PART DESCRIPTION	PART NUMBER
1	Front panel	JKR 74076
2	Pressure Switch	PRS 74326
3	Flue gas collector	MSC 74112
4	Seal ring 60mm	GKT 74022
5	Seal ring flue gas collector-heat exchanger	GKT 74021
6	Hose pressure switch	MSC 74048
7	Hand air vent	MSC 74021
8	Burner room insulation (target wall)	FIB 74098
9	Heat Exchanger	C/F
10a	High limit thermostat 195°F	HLC 74066
10b	High limit thermostat 225°F	HLC 74274
11	Gasket burner door - heat exchanger	GKT 74035
12	Heat Exchanger Clamps	HEX 74037
13	Sensor Clamp 18mm	TST 74395
14	Inlet Tube Assembly	C/F
15	Outlet Tube Assembly	C/F
16	O-Ring Quick Connect	GKT 74027
17	Clip Quick Connect (specify copper or stainless arms)	C/F
18	Insulation burner door	FIB 74093
19	Inlet / Outlet sensors NTC	TST 74287
20	Equipped burner door	BNR 74056

MAINTENANCE

I. EVO MICRO (HW 79-199.1 & 199.8) PARTS BREAKDOWN (CONTINUED)

NUMBER ON DRAWING	PART DESCRIPTION	PART NUMBER
21	Nut with flange 6ea. (M6 x 0.1)	MSC 74012
22,24	Electrode Assembly	PLT 74058
23	Flow Switch	C/F
25	Ignition cable with plug	WRE 74064
26	Burner	C/F
27	Gasket burner & gas / air inlet pipe	GKT 74029
28	Gas / air mixing pipe fan to burner	BNR 74018
29	Gasket gas / air inlet pipe & fan	C/F
30	Fan RG 128	C/F
31	Gas / air mixing plate	C/F
32	Condensate Drain Tube (with connection for hose pressure switch)	CDK 74122
33	Coil EV1 gas valve	VAL 74347
34	Coil EV2 gas valve	VAL 74348
35	Gas valve	VAL 74115
36	Coverplate boiler control	C/F
38	Display-unit DU 914 incl. cable	RLY 74061
39	Cover connector	MSC 74062
40	Distance Nut	C/F
41	Boiler control FMT 914	RLY 74062
42	Switch On / Off	SWT 74144
43	Condensate Drain Assembly	CDK 74124
44	Condensate Drain Hose	CDK 74038
45	Rubber Adapter (air inlet condense hose)	MSC 74074
46	Condense Hose	CDK 74001
47	Seal inside trap	CDK 74041
49	Swivel Nut	CDK 74133
50	Connector	CDK 74132
51	Gasket	GKT 74033
52	Gasket	GKT 74037
53	Reducing Ring	MSC 74075
54	Wall Bracket	JKR 74014
55	Rubber Stop	GKT 74092
56	Flue Gas Connection	C/F
57	Spread Nut	MSC 74093
58	Non-Return Damper	VAL 74096
59	Condense Flange w/Nipple	CDK 74017
60	Inlet Air Connection	C/F
61	Condense Flange Gasket	GKT 74079
	Immersion Style 1/2" NPT w/4" stem with well	TST 71010
	Strap-on 2" - 5" pipe	TST 71020
	Outdoor sensor style - weatherproof enclosure	TST 71030
	Sensor Tank 1/8" NPT with 5' lead and 1" probe	TST 76071
	Sensor Tank - 7' lead and 2' x 3/16" probe for well	TST 76110
	Sensor Tank 1/8" NPT with 5' lead and 3" probe	TST 76010
	Circuit Board Cascade Unit	RLY 74300
	Circuit Board Open Therm (Communications)	RLY 74356
	3.15A Fuse	FUS 74315

C/F=Consult Factory

J. EVO DUO (HW 299-599) PARTS BREAKDOWN

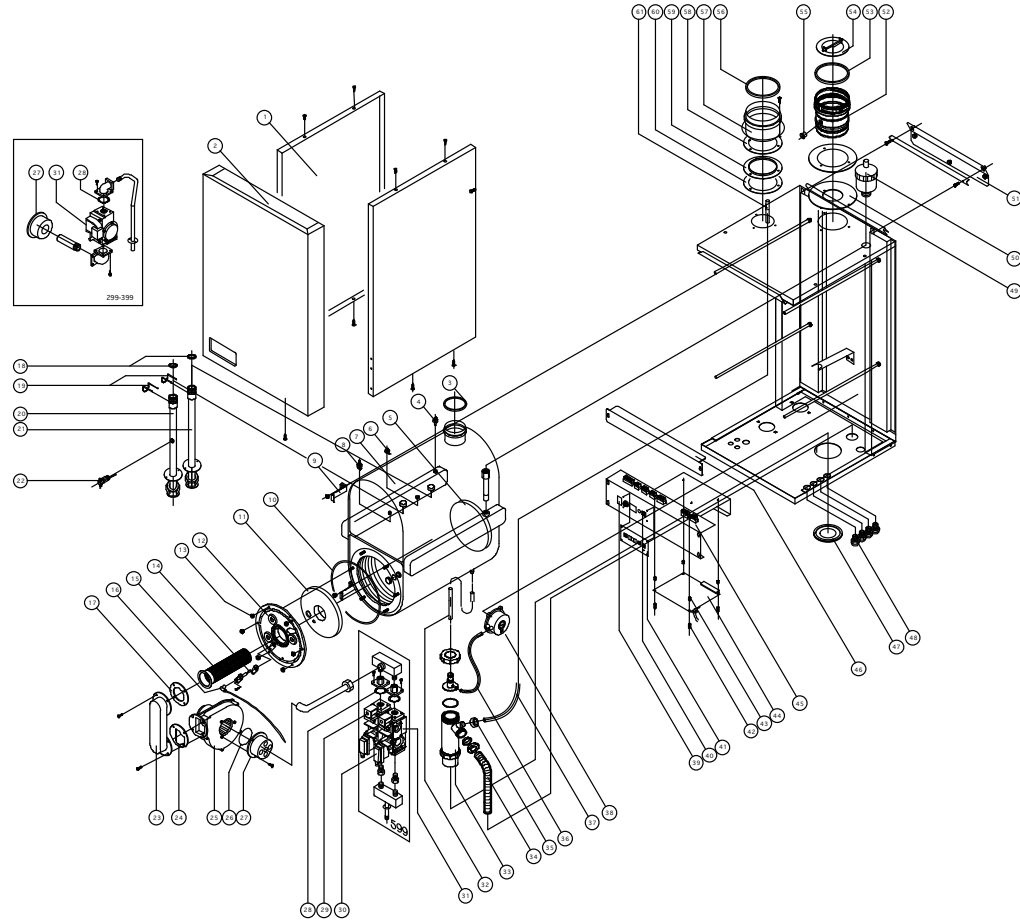

NO. ON DRAWING	PART DESCRIPTION	PART NO. 299	PART NO. 399	PART NO. 599
1	Side panel	JKR 74071	JKR 74071	JKR 74072
2	Front panel	JKR 74073	JKR 74073	JKR 74074
3, 53, 56	Seal ring 115mm / 130mm	GKT 74031	GKT 74031	GKT 74025
4, 8	Inlet / Outlet Sensor NTC	TST 74287	TST 74287	TST 74287
5	Burner room insulation (target wall)	C/F	C/F	C/F
6a	High limit thermostat 195°F	HLC 74066	HLC 74066	HLC 74066
6b	High limit thermostat 225°F	HLC 74274	HLC 74274	HLC 74274
7	Heat Exchanger	C/F	C/F	C/F
10	Gasket burner door - heat exchanger	GKT 74035	GKT 74035	GKT 74035
11	Insulation burner door	FIB 74093	FIB 74093	FIB 74093
12	Equipped burner door incl. gasket & cord	BNR 74056	BNR 74056	BNR 74056
13	Nut with flange 6 ea. M6 x 0.1	MSC 74012	MSC 74012	MSC 74012
14	Electrode Assembly	PLT 74058	PLT 74058	PLT 74058
15	Burner	C/F	C/F	C/F
16	Ignition cable with plug	WRE 74064	WRE 74064	WRE 74064
17	Gasket burner & gas / air inlet pipe	GKT 74029	GKT 74029	GKT 74029
18	O-Ring Quick Connect	GKT 74032	GKT 74033	GKT 74034
19	Clip Quick Connect	MSC 74022	MSC 74022	MSC 74023
20	Outlet Tube Assembly	C/F	C/F	C/F
21	Inlet Tube Assembly	C/F	C/F	C/F

MAINTENANCE

J. EVO DUO (HW 299-599) PARTS BREAKDOWN (CONTINUED)

NO. ON DRAWING	PART DESCRIPTION	PART NO. 299	PART NO. 399	PART NO. 599
22	Flow Switch	C/F	C/F	C/F
23	Air / gas mixing pipe - fan to burner	BNR 74018	BNR 74018	BNR 74016
24	Gasket air / gas inlet pipe & fan	GKT 74049	GKT 74049	GKT 74039
25	Fan RG 148 - 175, including "O" ring	FAN 74069	FAN 74069	FAN 74070
26	O-ring mixing box - fan	GKT 74007	GKT 74007	GKT 74029
27	Air / gas mixing box	FAN 74058	FAN 74058	FAN 74061
29	Coil EV1 gas valve	VAL 74348	VAL 74348	VAL 74348
30	Coil EV gas valve	VAL 74347	VAL 74347	VAL 74347
31	Gas valve, including seal ring	VAL 74059	VAL 74059	VAL 74060
32	Condensate Drain Tube	CDK 74044	CDK 74044	CDK 74029
33	Condensate drain assembly	CDK 74124	CDK 74124	CDK 74124
34	Condensate drain hose	CDK 74038	CDK 74038	CDK 74038
35	Rubber Adaptor for air inlet condense hose	GKT 74074	GKT 74074	GKT 74074
36	Hose Pressure switch	MSC 74055	MSC 74055	MSC 74055
37, 61	Condense Hose	CDK 74001	CDK 74001	CDK 74001
38	Pressure Switch	PRS 74326	PRS 74326	PRS 74326
39	Switch On / Off	SWT 74144	SWT 74144	SWT 74144
40	Plastic cover connector	MSC 74062	MSC 74062	MSC 74062
41	Display-unit DU 914 including cable	RLY 74061	RLY 74061	RLY 74061
42	Distance Nut	C/F	C/F	C/F
43	Distance Nut	C/F	C/F	C/F
44	Boiler control (PCB) - FMT 914	RLY 74062	RLY 74062	RLY 74062
45	Display Holder - 28	C/F	C/F	C/F
46	Cover plate boiler control	C/F	C/F	C/F
47	Tube Gland Trap	GKT 74044	GKT 74044	GKT 74044
48	Strain Relief 8mm	MSC 74064	MSC 74064	MSC 74064
49	Silicon Gasket Flue	GKT 74081	GKT 74081	GKT 74081
50	Automatic Air Vent	HYD 72400	HYD 72400	HYD 72400
52	Flue Gas Connection	C/F	C/F	C/F
54	Non return damper	VAL 74097	VAL 74097	VAL 74098
55	Rubber Stop	GKT 74092	GKT 74092	GKT 74092
57	Air inlet connection	C/F	C/F	C/F
58, 60	Condense flange gasket - air inlet	C/F	C/F	C/F
59	Condense flange w/Nipple	CDK 74018	CDK 74018	CDK 74009
	Immersion style 1/2" NPT w/4" stem with well	TST 71010	TST 71010	TST 71010
	Strap-on 2" - 5" pipe	TST 71020	TST 71020	TST 71020
	Outdoor sensor style - weatherproof enclosure	TST 71030	TST 71030	TST 71030
	Sensor Tank 1/8" NPT with 5' lead and 1" probe	TST 76071	TST 76071	TST 76071
	Sensor Tank - 7' lead and 2" x 3/16" probe for well	TST 76110	TST 76110	TST 76110
	Sensor Tank 1/8" NPT with 5' lead and 3" probe	TST 76010	TST 76010	TST 76010
	Circuit Board Cascade Unit (not shown)	RLY74300	RLY74300	RLY74300
	Circuit Board Open Therm (not shown)	RLY 74356	RLY 74356	RLY 74356
	3.15A Fuse	FUS 74315	FUS 74315	FUS 74315

UNIVERSAL WIRING DIAGRAM

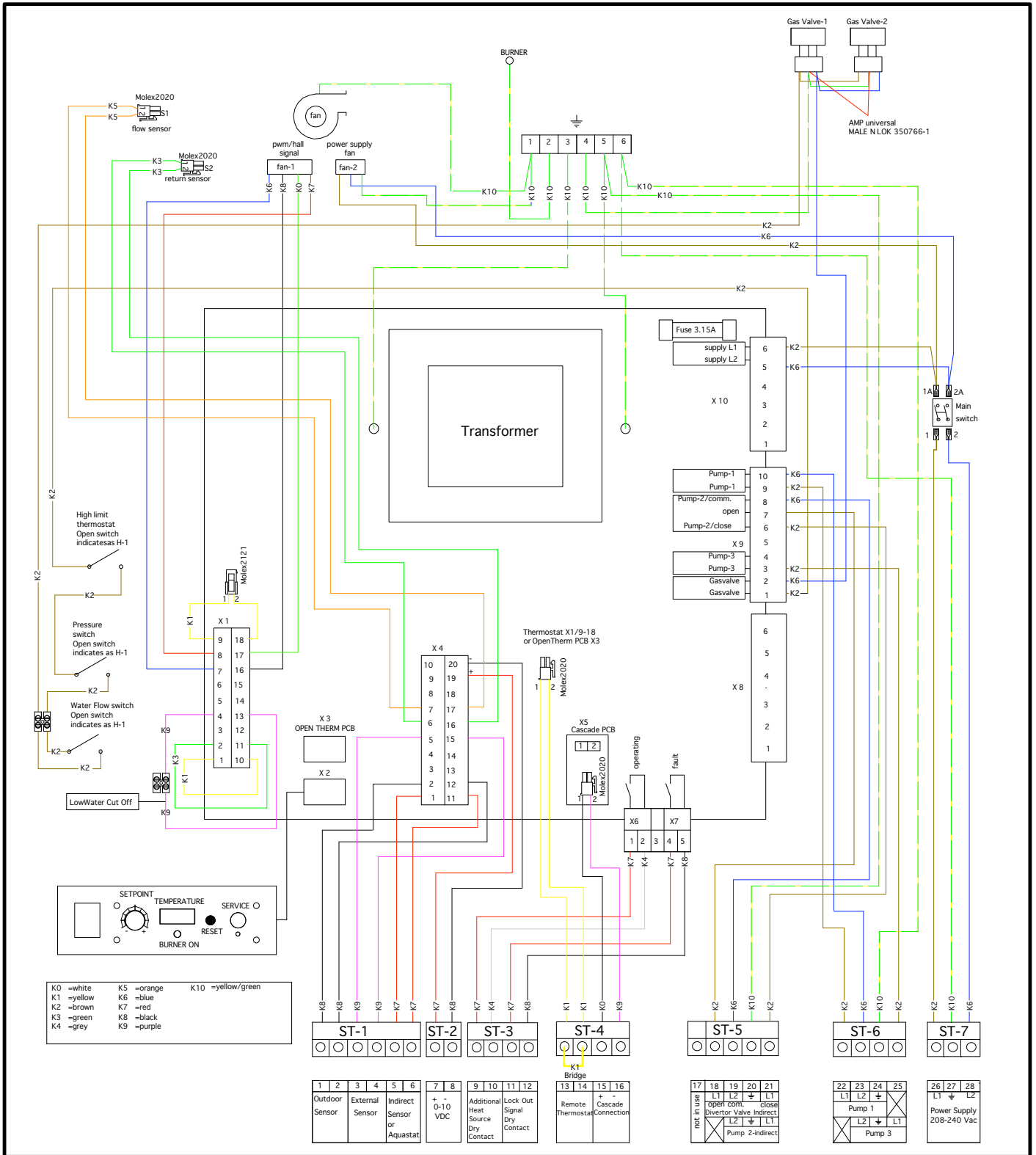

34000 Autry St.
Livonia, MI 48150
PH: (800) 968-5530
Fax: (734) 419-0209

Dwg. By:	Date:	Scale:
	03/23/09	NTS
Customer:		
Description:		
Universal Wiring Diagram HW 79 - 599		

Requirements for installation – Commonwealth of Massachusetts

For all side wall horizontally vented gas fueled equipment installed in every dwelling, building or structure used in whole or in part for residential purposes, including those owned or operated by the Commonwealth and where the side wall exhaust vent termination is less than seven (7) feet above finished grade in the area of the venting, including but not limited to decks and porches, the following requirements shall be satisfied:

1. **INSTALLATION OF CARBON MONOXIDE DETECTORS.** At the time of installation of the side wall horizontal vented gas fueled equipment, the installing plumber or gasfitter shall observe that a hard wired carbon monoxide detector with an alarm and battery back-up is installed on the floor level where the gas equipment is to be installed. In addition, the installing plumber or gasfitter shall observe that a battery operated or hard wired carbon monoxide detector with an alarm is installed on each additional level of the dwelling, building or structure served by the side wall horizontal vented gas fueled equipment. It shall be the responsibility of the property owner to secure the services of qualified licensed professionals for the installation of hard wired carbon monoxide detectors

- a. In the event that the side wall horizontally vented gas fueled equipment is installed in a crawl space or an attic, the hard wired carbon monoxide detector with alarm and battery back-up may be installed on the next adjacent floor level.
- b. In the event that the requirements of this subdivision can not be met at the time of completion of installation, the owner shall have a period of thirty (30) days to comply with the above requirements; provided, however, that during said thirty (30) day period, a battery operated carbon monoxide detector with an alarm shall be installed.

2. **APPROVED CARBON MONOXIDE DETECTORS.** Each carbon monoxide detector as required in accordance with the above provisions shall comply with NFPA 720 and be ANSI/UL 2034 listed and IAS certified.

3. **SIGNAGE.** A metal or plastic identification plate shall be permanently mounted to the exterior of the building at a minimum height of eight (8) feet above grade directly in line with the exhaust vent terminal for the horizontally vented gas fueled heating appliance or equipment. The sign shall read, in print size no less than one-half (1/2) inch in size, "GAS VENT DIRECTLY BELOW. KEEP CLEAR OF ALL OBSTRUCTIONS".

4. **INSPECTION.** The state or local gas inspector of the side wall horizontally vented gas fueled equipment shall not approve the installation unless, upon inspection, the inspector observes carbon monoxide detectors and signage installed in accordance with the provisions of 248 CMR 5.08(2)(a)1 through 4.

(b) **EXEMPTIONS:** The following equipment is exempt from 248 CMR 5.08(2)(a)1 through 4:

1. The equipment listed in Chapter 10 entitled "Equipment Not Required To Be Vented" in the most current edition of NFPA 54 as adopted by the Board; and
2. Product Approved side wall horizontally vented gas fueled equipment installed in a room or structure separate from the dwelling, building or structure used in whole or in part for residential purposes.

