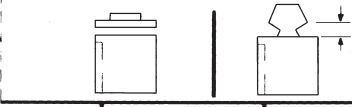

HOW TO USE YOUR RAYPAK ILLUSTRATED PARTS LIST

The Model Number, of a Raypak boiler, is found on the Rating Plate for the Boiler. Each Model number identifies the application, the construction and the function of the boiler and provides a positive means of providing information, both installation and service, and parts in a minimum amount of time. The example, shown below, should be used as a guide to identifying your boiler.

Model No: H3 - 1631

 <p>NATL. BD. 175968 CERTIFIED BY RAYPAK, INC. OXNARD, CALIFORNIA MAX W.P. WATER 160 PSI BTU/HR INPUT 1,630,000 MFR SERIAL NO 0010175968 MIN RELIEF VALVE CAP 1,337 LBS/HR HEATING SURFACE 129 SQ FT MAX WATER TEMP 250 °F</p>	<p style="text-align: center;">HOT WATER BOILER FOR INDOOR INSTALLATION ONLY</p> <p>MIN. CLEARANCES FROM COMBUSTIBLE CONSTRUCTION</p> <table style="width: 100%;"> <tr><td>RIGHT SIDE</td><td>24"</td></tr> <tr><td>LEFT SIDE</td><td>24"</td></tr> <tr><td>BACK</td><td>24"</td></tr> <tr><td>TOP</td><td>24"</td></tr> </table> <p>FOR SERVICING, PROVIDE AT LEAST 24" OF UNOBSTRUCTED CLEARANCE IN FRONT OF UNIT</p> <p>THIS BOILER SHALL BE INSTALLED IN A SPACE LARGE IN COMPARISON TO THE SIZE OF THE BOILER</p>	RIGHT SIDE	24"	LEFT SIDE	24"	BACK	24"	TOP	24"	<p>FOR INSTALLATION ON NON-COMBUSTIBLE FLOORS ONLY* * FOR INSTALLATION ON COMBUSTIBLE FLOORING ONLY WHEN INSTALLED ON SPECIAL BASE PART NUMBER</p> <table style="width: 100%; border-collapse: collapse;"> <tr> <td style="width: 25%;">MODEL</td> <td style="width: 25%;">PART NO</td> <td style="width: 25%;">MODEL</td> <td style="width: 25%;">PART NO</td> </tr> <tr> <td>982</td> <td>059233</td> <td>1468</td> <td>059237</td> </tr> <tr> <td>1125</td> <td>059234</td> <td>1631</td> <td>059238</td> </tr> <tr> <td>1223</td> <td>059235</td> <td>1826</td> <td>059239</td> </tr> <tr> <td>1336</td> <td>059236</td> <td></td> <td></td> </tr> </table> <p>ALL OPENINGS MUST REMAIN UNOBSTRUCTED BLOCKING OPENINGS WILL DAMAGE UNIT</p> <div style="text-align: center;">  </div> <table border="1" style="width: 100%; border-collapse: collapse;"> <tr> <th style="width: 33%;">MODEL</th> <th style="width: 33%;">OUTDOOR KIT#</th> <th style="width: 33%;">INDOOR KIT#</th> </tr> <tr> <td> </td> <td> </td> <td> </td> </tr> </table>	MODEL	PART NO	MODEL	PART NO	982	059233	1468	059237	1125	059234	1631	059238	1223	059235	1826	059239	1336	059236			MODEL	OUTDOOR KIT#	INDOOR KIT#			
RIGHT SIDE	24"																																			
LEFT SIDE	24"																																			
BACK	24"																																			
TOP	24"																																			
MODEL	PART NO	MODEL	PART NO																																	
982	059233	1468	059237																																	
1125	059234	1631	059238																																	
1223	059235	1826	059239																																	
1336	059236																																			
MODEL	OUTDOOR KIT#	INDOOR KIT#																																		
<p>BTU/HR OUTPUT 1,336,600 BTU/HR INPUT 1,630,000 MIN INPUT RATE 0 BTU/HR GAS NAT MODEL NO H3-1631 CATEGORY 1 BOILER</p> <p style="text-align: center;">ACCEPTED FOR USE CITY OF NEW YORK DEPARTMENT OF BUILDINGS MEAF# 407-88-E VOL II</p> <p>ANS Z21 13b-1994 LOW PRESSURE BOILER</p> <p>p/n 900808</p>	<table style="width: 100%;"> <tr> <td style="width: 33%;">MAX. PERMISSIBLE GAS SUPPLY PRESSURE</td> <td style="width: 33%;">NAT 14"W.C</td> <td style="width: 33%;">LPG 14"W.C</td> </tr> <tr> <td>MIN. PERMISSIBLE GAS SUPPLY PRESSURE FOR PURPOSE OF INPUT ADJUSTMENT</td> <td>7"W.C</td> <td>12"W.C</td> </tr> <tr> <td>MANIFOLD PRESSURE</td> <td>4"W.C</td> <td>11"W.C</td> </tr> </table> <p>ELECTRICAL RATING 120/24V 60 HZ. LESS THAN 12 AMPERES</p> <p>WHEN USED WITH POWER VENT TERMINAL NO. 005733 ELECTRICAL RATING WILL BE LESS THAN 20 AMPS, 120 VAC, 60 HZ</p>	MAX. PERMISSIBLE GAS SUPPLY PRESSURE	NAT 14"W.C	LPG 14"W.C	MIN. PERMISSIBLE GAS SUPPLY PRESSURE FOR PURPOSE OF INPUT ADJUSTMENT	7"W.C	12"W.C	MANIFOLD PRESSURE	4"W.C	11"W.C																										
MAX. PERMISSIBLE GAS SUPPLY PRESSURE	NAT 14"W.C	LPG 14"W.C																																		
MIN. PERMISSIBLE GAS SUPPLY PRESSURE FOR PURPOSE OF INPUT ADJUSTMENT	7"W.C	12"W.C																																		
MANIFOLD PRESSURE	4"W.C	11"W.C																																		

Raytherm Type Designations

CURRENT TYPE DESIGNATION	FIRING MODE	OLD TYPE DESIGNATION	MODELS	CURRENT TYPE TEMPERATURE RANGE
H1	MECH MOD	T	133-1826	150-210
H2	MOTOR MOD	TA	514-4001	160-260
H3	TWO-STAGE	TB	181-4001	130-230
H4	ON/OFF	TC	181-4001	100-240
H5	LOW TEMP MOD	TD	400-1826	110-170
H6	MOTOR MOD	TX WITH B-3	514-4001	B6000*
H9	FOUR-STAGE	NEW	514-4001	-40-220
WH1	ON/OFF	WT, W1	133-4001	100-200
WH2	MECH MOD	THWS, W2	133-1826	110-170
WH2	MOTOR MOD	THWS, W2	2100-4001	104-220
WH3	TWO-STAGE	W3	181-4001	130-230
NH - Obsolete	MECH MOD (INSTANTANEOUS)	TIP OR THWS WITH TIP AT END OF S/N	514-1826	110-170
RH - Obsolete	MECH MOD	TIPR OR THWS WITH TIPR AT END OF S/N	514-1125	150-210
WH	ON/OFF - ECONOPAK	N/A	90-403	105-205
P	ON/OFF - POOL	WG	514-4001	40-105

Now find the part you need in the exploded view drawing. After you find the part you will notice a number and letter next to the part. See Drawing below. This is referred to as a "Call Out".

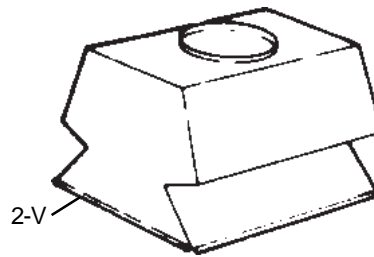

The number serves as a "Finder" number and has no specific part classification.

The letter serves as a "Part Class" identification number. The letters stand for specific groups of parts - see Example below.

- | | |
|-------------------------|-------------------|
| B - BURNER TRAY | M - MISCELLANEOUS |
| C - CONTROLS | P - PILOT |
| G - GASVALVES | R - REFRACTORY |
| H - HEAT EXCHANGER | S - SHEET METAL |
| J - J-BOX (CONTROL BOX) | V - VENTING |

To find the Raypak Part Number, refer to the parts list located on the page opposite to the exploded view drawing.

Now take the call-out you found in the exploded view and match it to the call-out in the left hand column. You will notice the parts are to groups. These are grouped into "Part Classes". See Example below.

Call-Out Column

CALL OUT	DESCRIPTION	185	265	335	405
H	HEAT EXCHANGER				
1-H	Heat Exchange Assy. Cast Iron (Complete)	005244F	005245F	005246F	005247F
	Heat Exchange Assy. Brass (Complete)	005248F	005249F	005250F	005251F
2-H	Inlet/Outlet Header CI	003759F	003759F	003759F	003759F
	Inlet/Outlet Header BR	003760F	003760F	003760F	003760F
3-H	Return Header CI	002450F	002450F	002450F	002450F
	Return Header BR	002451F	002451F	002451F	002451F
4-H	Tube Bundle	005252F	005253F	005254F	005255F
5-H	Heat Exchanger Tube (1)	005256F	005257F	005258F	005259F
6-H	Baffle Kit (8)	005260F	005261F	005262F	005263F
7-H	Bolt Kit	001303F	001303F	001303F	001303F
8-H	Header Gasket (9)	800014B	800014B	800014B	800014B
9-H	Unitherm Governor	062234B	062234B	062234B	062234B
10-H	U.G. Retainer Spring	850254	850254	850254	850254
11-H	Bypass Valve	062235B	062235B	062235B	062235B
12-H	Bypass Spring	850252	850253	850253	850253
13-H	Drain Valve	500719	500719	500719	500719
14-H	Sensor Well	003765F	003765F	003765F	003765F
15-H	Well Retaining Clip	300203	300203	300203	300203
16-H	Inlet & Outlet Flange	003766F	003766F	003766F	003766F
17-H	Flange Gasket 1 1/2" Connections	062236B	062236B	062236B	062236B
	Flange Gasket 2" Connections	800080B	800080B	800080B	800080B
18-H	Rear Drain Plug & Cover	005264F	005264F	005264F	005264F

H Class

You will also notice that some of the call-out's are indented. The indentations represent parts that are included in the assemblies listed directly above the indentation. You can order the complete assembly or the indented parts separately. If the part or assembly does not offer separate parts there will be no indentations.

Assembly	6-B	Burner Tray w/Burners
	7-B	Manifold - Lower
Parts included in Assembly	8-B	Manifold - Upper
	9-B	Burner Hold Down Bracket
	10-B	Burner Spacer



COMMERCIAL
MODELS: XTHERM 1005 THROUGH 2005

CATALOG NO. 9300.742
Effective: 07-27-12
Replaces: 05-03-12

RAYPAK ILLUSTRATED PARTS LIST

MODEL SIZES: 1005, 1505 & 2005

MODEL TYPES: MODULATING VERTICAL BOILER H, WH, & WHP CAT IV

DATES OF MANUFACTURE: 09-01-08 THROUGH CURRENT

THE PARTS LISTED ARE FOR STANDARD EQUIPMENT FOR THIS MODEL TYPE. RAYPAK RESERVES THE RIGHT TO SUBSTITUTE, DELETE OR CHANGE ANY PART WITHOUT NOTIFICATION. THE ADDITION OF OPTIONS MAY ALSO CHANGE SOME OF THE PARTS. ORDER REPLACEMENT PARTS FROM ACTUAL HEATER COMPONENTS.



FOR DETAILED INSTRUCTIONS, SEE "HOW TO USE YOUR RAYPAK ILLUSTRATED PARTS LIST",
CATALOG NO. 9001.10



Raypak, Inc., 2151 Eastman Avenue, Oxnard, CA 93030
(805) 278-5300 FAX (805) 278-5489
Litho In U.S.A.

P/N 241345

HEAT EXCHANGER DETAIL

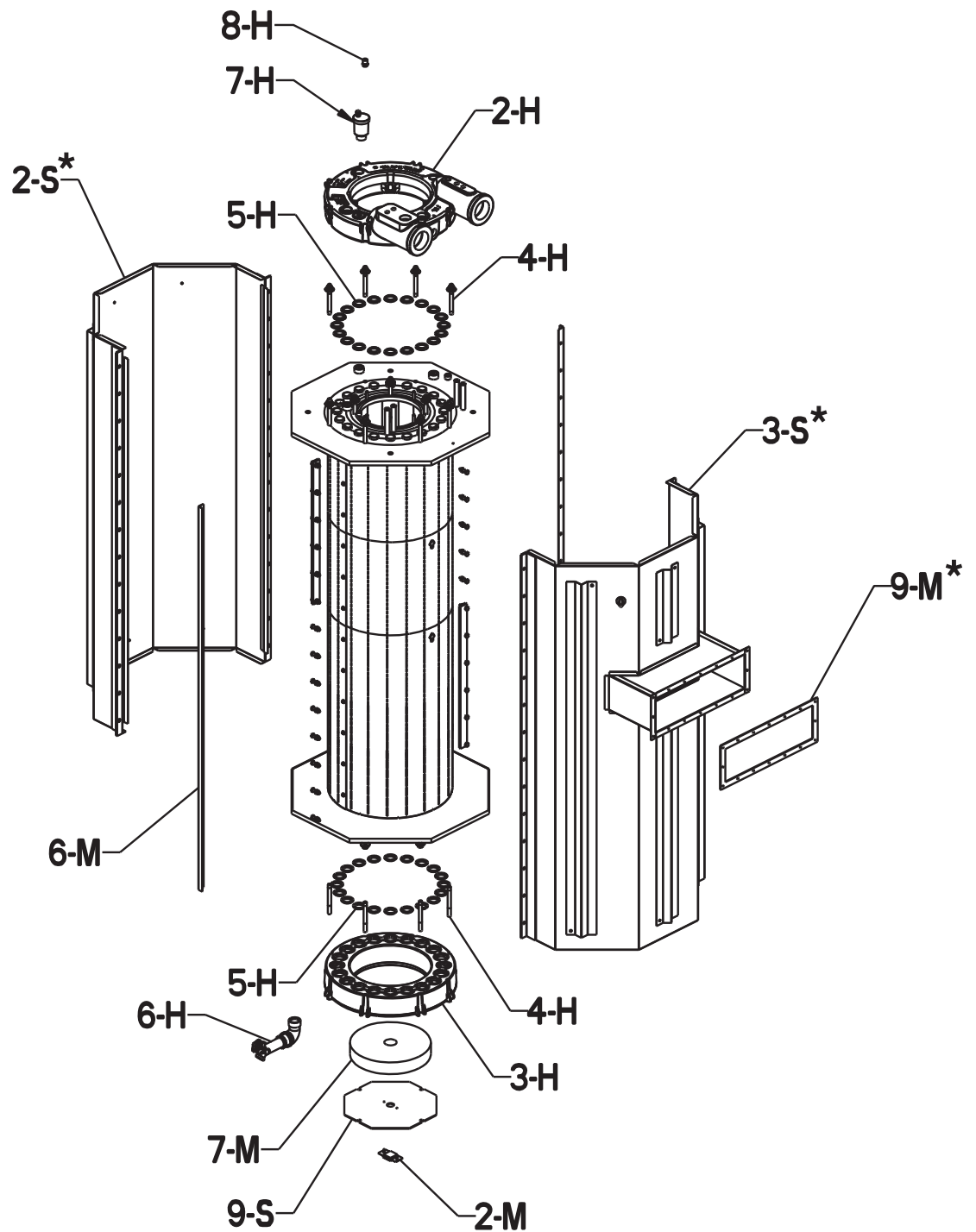

*SURFACES REQUIRE HIGH-TEMPERATURE RTV SEALANT (ITEM 5-M). FOLLOW MANUFACTURER'S INSTRUCTIONS.

J-BOX DETAIL

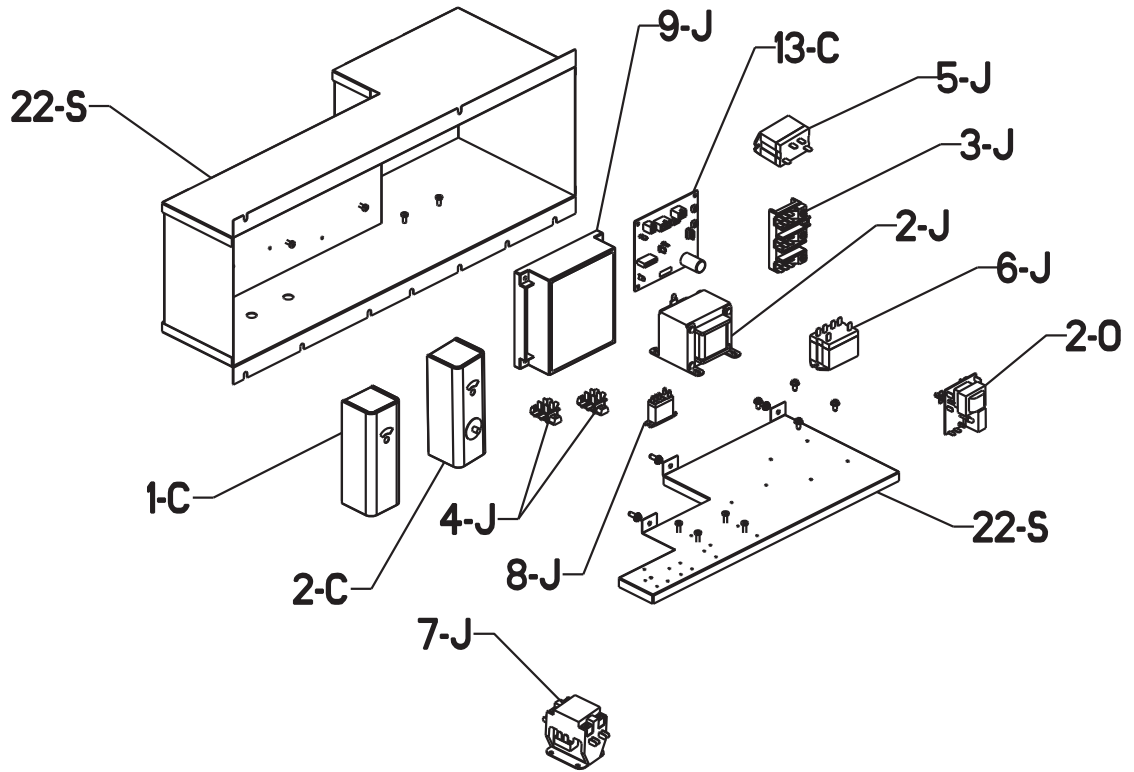

GAS TRAIN DETAIL

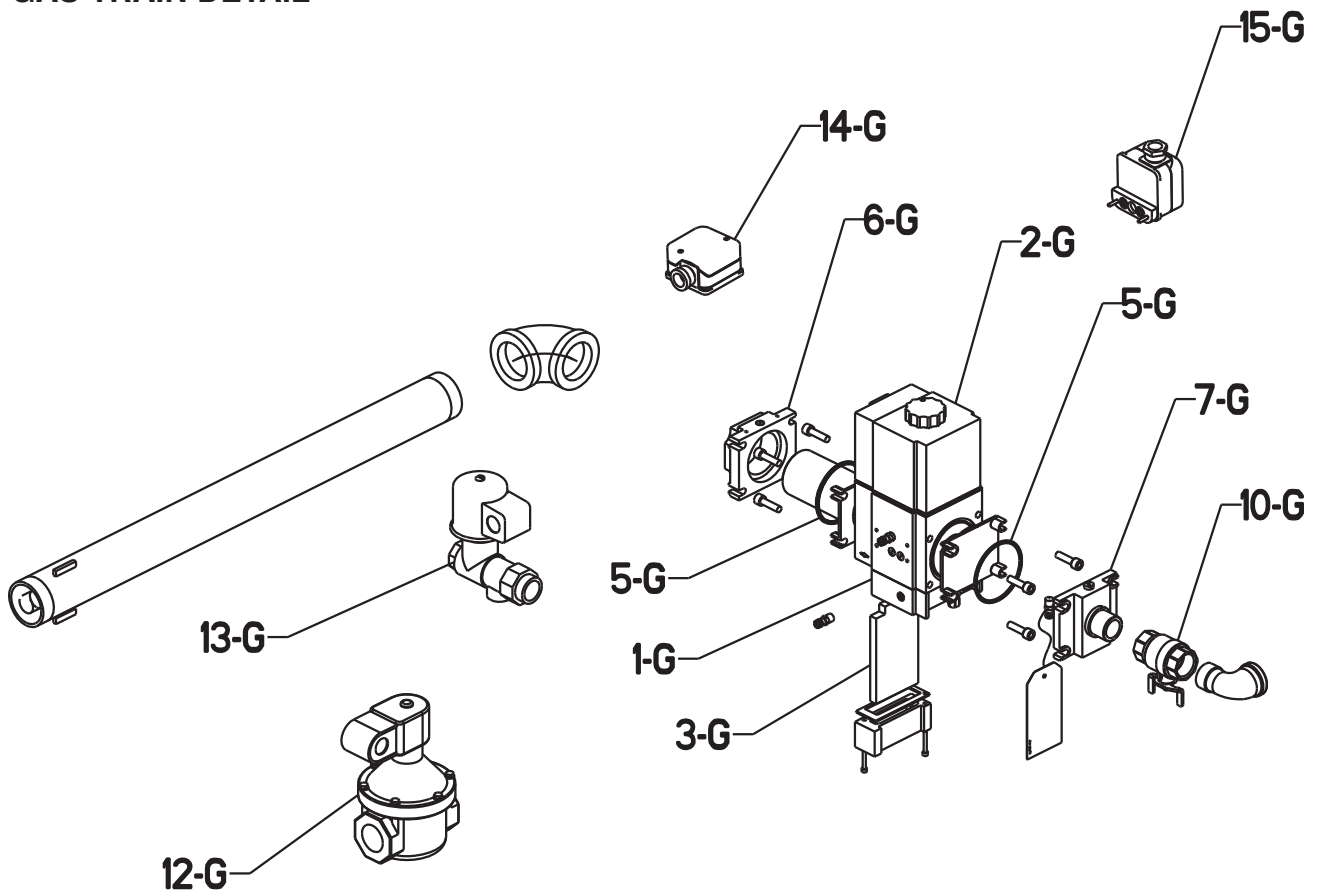

BLOWER DETAIL

MODELS 1005 & 1505

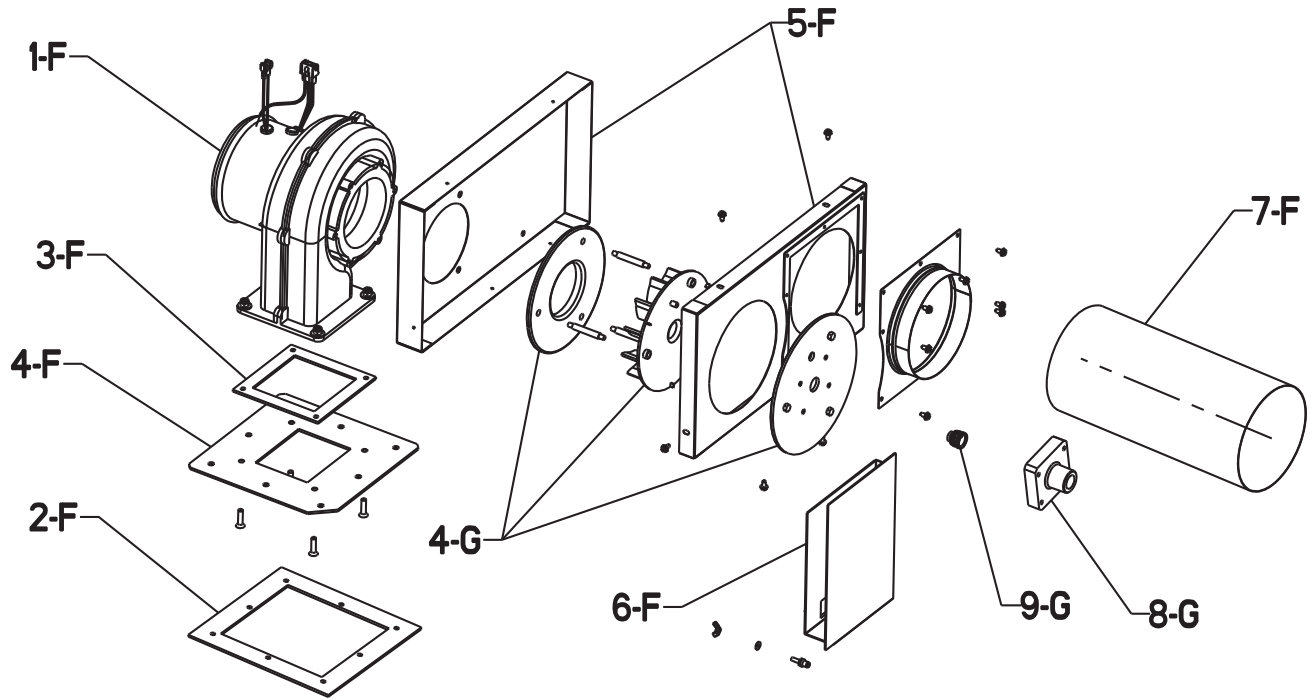

MODEL 2005

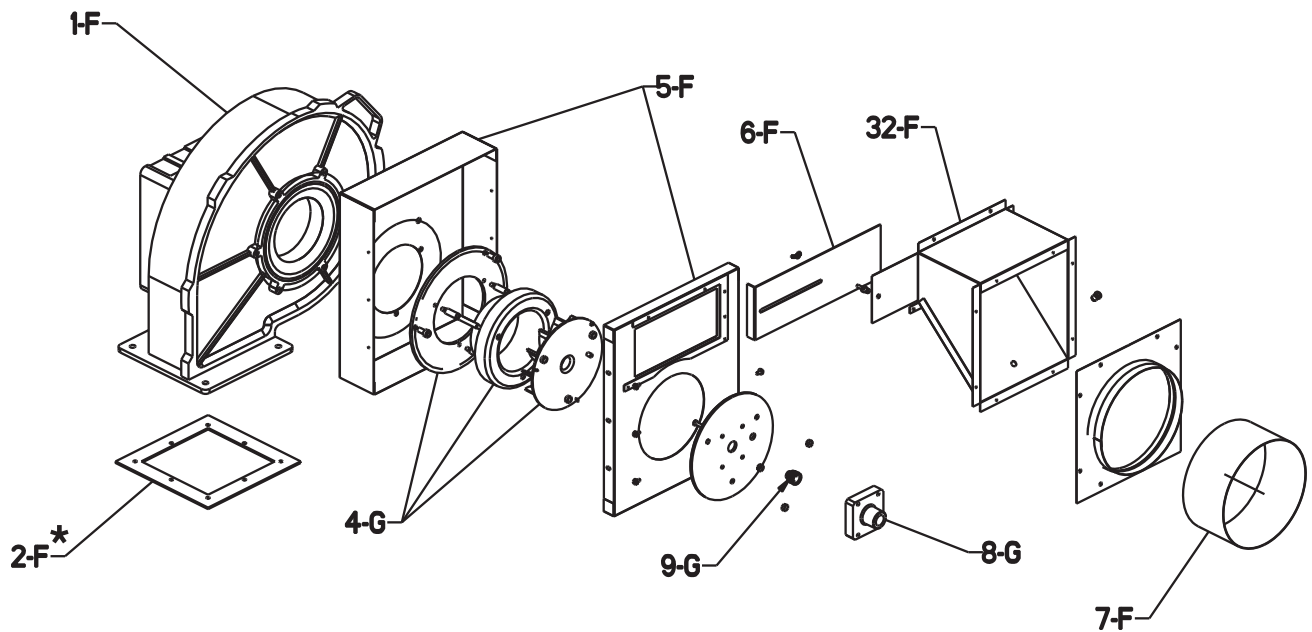

*SURFACES REQUIRE HIGH-TEMPERATURE
RTV SEALANT (ITEM 5-M). FOLLOW
MANUFACTURER'S INSTRUCTIONS.

BYPASS DETAIL

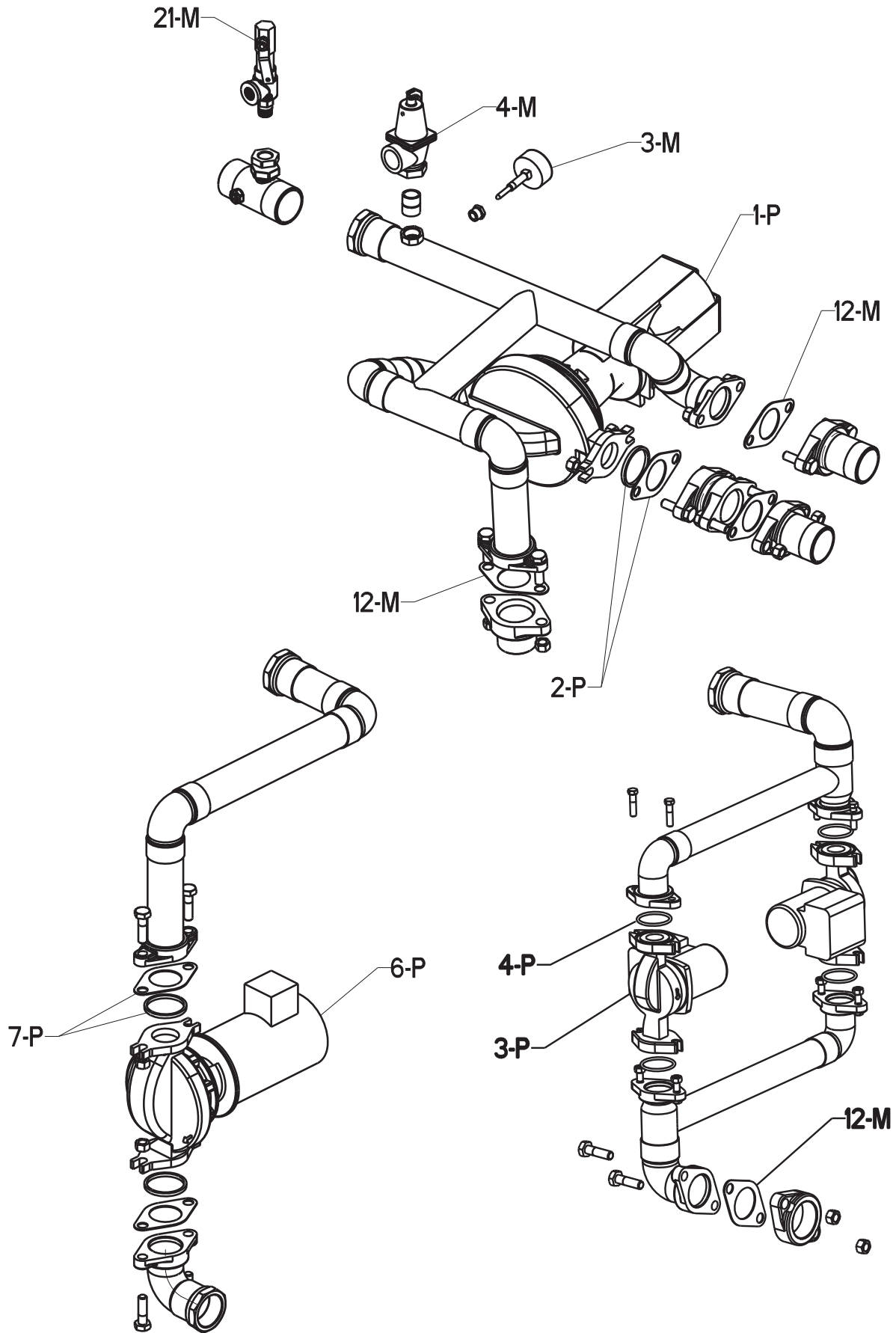

SECONDARY HEAT EXCHANGER DETAIL

CAUTION
39-S PVC VENT ADAPTER
AVAILABLE FOR REPAIR
ONLY. NOT AVAILABLE
FOR FIELD CONVERSION.

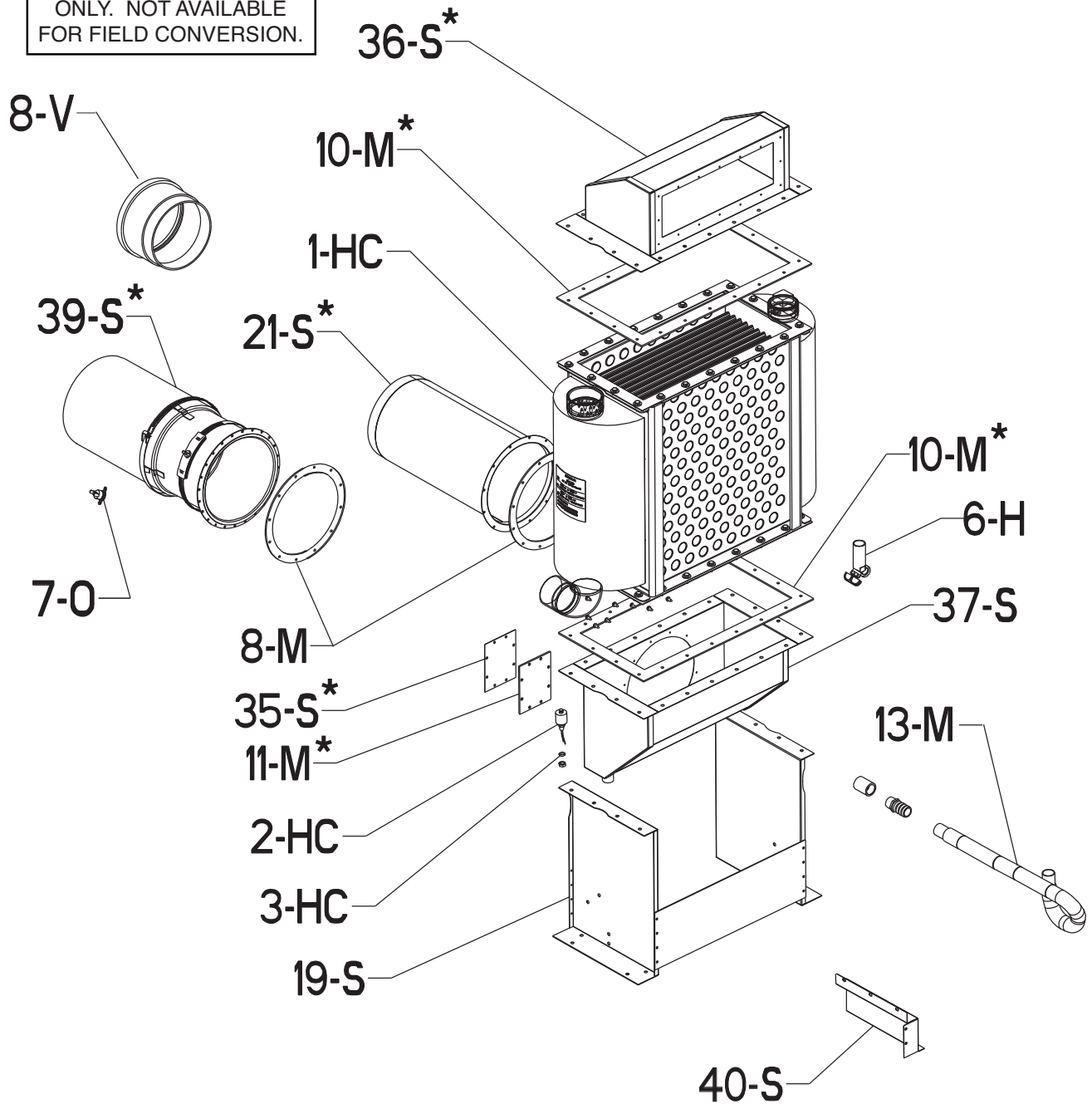

*SURFACES REQUIRE HIGH-TEMPERATURE
RTV SEALANT (ITEM 5-M). FOLLOW
MANUFACTURER'S INSTRUCTIONS.

CALL OUT	DESCRIPTION	1005	1505	2005
B	BURNER ASSEMBLY			
1-B	Adapter Assembly	011749F	011749F	011750F
2-B	Adapter Gaskets and Heat Shield	011751F	011751F	011751F
3-B	Flame Sensor Probe	011752F	011752F	011752F
4-B	Igniter	007400F	007400F	007400F
5-B	Burner	011754F	011755F	011756F
C	CONTROLS			
1-C	Auto Reset Adjustable High Limit 240F Max	011860F	011860F	011860F
	Auto Reset Adjustable High Limit 180F Max	006445F	006445F	006445F
	Auto Reset Adjustable High Limit 200F Max	012546F	012546F	012546F
2-C	Manual Reset Adjustable High Limit 240F	007144F	007144F	007144F
	Manual Reset Adjustable High Limit 200F	008081F	008081F	008081F
3-C	Manual Reset Fixed High Limit 240F	008520F	008520F	008520F
	Manual Reset Fixed High Limit 200F	008093F	008093F	008093F
4-C	Remote Aquastat (Tankstat) 2-Stage B-3 (Not Shown)	007392F	007392F	007392F
5-C	Controller Modulating (Tekmar) H7 & WH7	012407F	012407F	012407F
	Controller On/Off (Tekmar) WHP	012253F	012253F	012253F
6-C	Controller 4-Stage B-21 / B-23 Digital Optional (Not Shown)	009862F	009862F	009862F
	Controller 2-Stage B-26 / B-27 Digital Optional (Not Shown)	009861F	009861F	009861F
7-C	Sensor Outdoor Air B-32	010786F	010786F	010786F
8-C	Sensor Water B-21 thru B-27	010787F	010787F	010787F
9-C	Sensor Water screw-In (Tekmar)	011861F	011861F	011861F
11-C	Flow Switch	007142F	007142F	007142F
12-C	Printed Circuit Board UDB (Diagnostic)	012571F	012571F	012571F
13-C	Printed Circuit Board UGB (Blower)	N/A	N/A	011759F
14-C	Printed Circuit Board CWR	011717F	011717F	011717F
20-C	Relay DPDT 24VDC	005962F	005962F	005962F
15-C	CWR Control (Inverter)	012661F	012661F	012661F
19-C	Chip - Inverter Prog	013069F	013069F	013069F
16-C	Diagnostic Display	012662F	012662F	012662F
17-C	Air Vent Pressure Switch	011760F	011760F	011760F
18-C	Air Intake Pressure Switch	011761F	011761F	011761F
J	CONTROL BOX			
1-J	Control Box Complete	N/A	N/A	N/A
2-J	Transformer 120/24 100 VA	007373F	007373F	N/A
	Transformer 120/24 150 VA	N/A	N/A	011762F
3-J	Terminal Block w / Ground Lug	008523F	008523F	008523F
4-J	Terminal Block 2 Space	011763F	011763F	011763F
5-J	Blower Relay 120 VAC	008977F	008977F	N/A
6-J	Pump Relay 24 VAC	007925F	007925F	007925F
7-J	Pump Contactor 120 VAC	007906F	007906F	007906F
14-J	Relay DPDT 120 VAC	013243F	013243F	013243F
8-J	Relay SPDT 24 VAC (Alarm)	009039F	009039F	009039F
	Relay SPDT 24 VAC (Enable/Disable)	009039F	009039F	009039F
	Relay SPDT 24 VAC (Remote Status)	009039F	009039F	009039F
9-J	Ignition Control HSI Single Try	009057F	009057F	009057F
	Ignition Control HSI Three Try	007374F	007374F	007374F
10-J	Rocker Switch (Burner / Pump)	006872F	006872F	006872F
11-J	On / Off Shut Down Switch	007380F	007380F	007380F
12-J	Reset Switch (CWR)	005641F	005641F	005641F
13-J	Indicator Lamp	011848F	011848F	011848F
F	FAN			
1-F	Blower Combustion Air	012444F	012446F	011765F
2-F	Adapter Gasket	011885F	011885F	011885F
3-F	Adapter Gasket	011886F	011886F	N/A
4-F	Adapter Plate	011887F	011887F	N/A
5-F	Plenum Assembly	011863F	011863F	011864F
6-F	Air Shutter	011875F	011875F	011876F
7-F	Hose Duct 6"	007420F	007420F	N/A
	Hose Duct 8"	N/A	N/A	012680F

CALL OUT	DESCRIPTION	1005	1505	2005
G	GAS TRAIN			
1-G	Valve Gas Modulating (Dungs) Natural Gas	011766F	011766F	011768F
	Valve Gas Modulating (Dungs) Propane Gas	011766F	011766F	011766F
2-G	Valve Coil Nat	012310F	012310F	012311F
	Valve Coil Pro	012310F	012310F	012310F
3-G	Inlet Gas Filter	012294F	012294F	012295F
4-G	Swirler	011888F	011888F	011889F
5-G	O Rings (Includes Gas Valve and Adapter O Rings)	012440F	012440F	012441F
6-G	Adapter Gas Valve 1" Inlet	011915F	011915F	011915F
	Adapter Gas Valve 1-1/4" Inlet	011916F	011916F	N/A
	Adapter Gas Valve 2" Inlet	N/A	N/A	011917F
7-G	Adapter Gas Valve Outlet	012545F	012545F	012297F
8-G	Adapter Swirl Plate	012298F	012298F	012298F
9-G	Nozzle Natural Gas	012301F	012303F	012305F
	Nozzle Propane Gas	012308F	012308F	012301F
10-G	Valve Gas Ball (WOG)	011769F	011769F	011769F
11-G	Motorized Safety Shut Off Valve (Optional Not Shown)	011908F	011908F	011908F
12-G	Solenoid Safety Shut Off Valve Nat (Optional)	011910F	011910F	011911F
	Solenoid Safety Shut Off Valve Pro (Optional)	011909F	011909F	011909F
13-G	Vent Valve Gas Nat (Optional)	011914F	011914F	011914F
	Vent Valve Gas Pro (Optional)	011913F	011913F	011913F
14-G	Switch Low Gas Pressure (Optional)	011770F	011770F	011770F
15-G	Switch High Gas Pressure (Optional)	011771F	011771F	011771F
H	HEAT EXCHANGER (Primary)			
1-H	Heat Transfer Cupronickel Bronze (Includes 18-S)	012574F	012575F	012576F
	Heat Transfer Cupro-Nickel Cast Iron (Includes 18-S)	012577F	012578F	012579F
	Heat Transfer Copper Bronze (Includes 18-S)	012580F	012581F	012582F
	Heat Transfer Copper Cast Iron (Includes 18-S)	012583F	012584F	012585F
2-H	Inlet/Outlet Header Bronze	009103F	009103F	009103F
	Inlet/Outlet Header Cast Iron	012332F	012332F	012332F
3-H	Return Header Bronze	007204F	007204F	007204F
	Return Header Cast Iron	012330F	012330F	012330F
4-H	Stud Bolt	009104F	009104F	009104F
5-H	Header Gasket (20 PCS)	007343F	007343F	007343F
6-H	Drain Valve	006536F	006536F	006536F
7-H	Air Vent Valve	011866F	011866F	011866F
8-H	Air Vent Waste Connector Adapter	013071F	013071F	013071F
HS	HEAT EXCHANGER (Condensing)			
1-HC	Heat Exch Stainless Steel (Includes 21-S)	012586F	012587F	012588F
2-HC	Condensate Float Switch	012589F	012589F	012589F
3-HC	O Ring Seal	012590F	012590F	012590F
M	MISCELLANEOUS COMPONENTS			
1-M	Flow Switch Paddle (Taco)	010026F	010026F	010026F
2-M	Window Combustion Chamber	006947F	006947F	006947F
3-M	T & P Gauge 0-90 PSI	007205F	007205F	007205F
	T & P Gauge 0-200 PSI	007399F	007399F	007399F
4-M	PRV 30 PSI	007748F	007748F	007748F
	PRV 45 PSI	007221F	007751F	007752F
	PRV 60 PSI	007222F	007753F	007754F
	PRV 75 PSI	007223F	007756F	007756F
	PRV 125 PSI	007224F	007224F	007758F
	PRV 150 PSI	007225F	007225F	007225F
21-M	UV PRV 150 PSI	013415F	013415F	013415F
5-M	RTV Sealant 2.8 oz (Not Shown)	008924F	008924F	008924F
	RTV Sealant 10 oz (Not Shown)	005755F	005755F	005755F
6-M	Flue Collector Vertical Seal Gasket	011772F	011772F	011772F
7-M	Insulation Blanket Return Header	007241F	007241F	007241F
8-M	Flue Exhaust Adapter Gasket Round	009735F	009736F	009736F
9-M	Flue Exhaust Adapter Gasket Rectangle	012591F	012592F	012592F
10-M	Plenum Gasket Upper and Lower	012593F	012593F	012594F
11-M	Access Panel Gasket Condensing Heat Exch	012595F	012595F	012595F
12-M	Flange Gasket 2" or 2-1/2" NPT	012596F	012596F	012596F
13-M	Condensate Hose	012597F	012597F	012597F
14-M	Condensate Neutralizer (Not Shown)	012050	012051	012051
15-M	Membrane Switch	012598F	012598F	012598F
16-M	Touch-Up Paint			
	Green	750125	750125	750125
	Dark Gray	750126	750126	750126
	Cool Dark Gray	750256	750256	750256
17-M	Inlet/Outlet Water Grommet 2-1/2" NPT	012663F	012663F	012663F
	PRV Discharge Grommet 1" Thru 1-1/4" NPT	010779F	010779F	010779F
18-M	Wire Harness	012652F	012652F	012652F
20-M	Plastic Handle	012681F	012681F	012681F

CALL OUT	DESCRIPTION	1005	1505	2005
O	OPTIONS			
1-O	Remote Sensor (LWCO)	007228F	007228F	007228F
2-O	Control PC Board (LWCO)	007157F	007157F	007157F
3-O	Test / Reset Switch (LWCO)	005641F	005641F	005641F
4-O	Silencer/Reset Switch (Alarm)	005641F	005641F	005641F
5-O	Alarm Bell 3"	005642F	005642F	005642F
	Alarm Bell 4"	005643F	005643F	005643F
6-O	Relay DPDT 24 VAC (Alarm)	011720F	011720F	011720F
7-O	Vent Limit Switch Manual Reset for PVC Venting	011868F	011868F	011868F
	Vent Limit Switch Manual Reset for Polypropylene Venting	014043F	014043F	014043F
P	PUMPS			
1-P	Bypass Pump Bronze (Soft Water)	011845F	011845F	007351F
	Bypass Pump Bronze (Medium Water)	011845F	007348F	007351F
	Bypass Pump Bronze (Hard Water)	007348F	007351F	
	Bypass Pump CI	011846F	011846F	950648
2-P	Pump Flange Gasket	013423F	013423F	013423F
3-P	Dual Injector Pump Bronze	012600F	012600F	012600F
	Dual Injector Pump CI	012601F	012601F	012601F
4-P	Pump Flange Gasket	008747F	008747F	008747F
5-P	Pump Cartridge	951153F	951153F	951153F
6-P	Injector Pump Bronze (WH)		012668F	012668F
	Injector Pump Bronze (WHP)	012669F	012669F	012669F
7-P	Pump Flange Gasket	013423F	013423F	013423F
S	SHEET METAL			
1-S	Jacket Top	012602F	012602F	012602F
2-S	Flue Collector Front (No Opening) (Includes 6-M)	011789F	011791F	011793F
3-S	Flue Collector Rear (Opening) (Includes 6-M and 9-M)	012603F	012604F	012605F
4-S	Heat Transfer Supports	012606F	012606F	012606F
5-S	Upper Cabinet Supports Front	012607F	012607F	012607F
6-S	Upper Cabinet Supports Rear	012608F	012608F	012608F
7-S	Upper Cabinet Supports Side	012609F	012609F	012609F
8-S	Vertical Cabinet Supports	012610F	012611F	012612F
9-S	Return Header Cover	007257F	007257F	007257F
10-S	Jacket Upper Front Panel	012613F	012613F	012614F
11-S	Jacket Lower Front Panel	012615F	012616F	012617F
12-S	Jacket Side Panel	012618F	012619F	012620F
13-S	Jacket Upper Rear Panel	012621F	012622F	012623F
14-S	Access Panel Intake Air	012671F	012671F	012671F
15-S	Jacket Lower Rear Panel w/ Access Panel	012624F	012625F	012626F
17-S	Base Assembly	012627F	012627F	012627F
18-S	Leg Bracket Primary Heat Exch (4 pcs per boiler)	007306F	007306F	007306F
19-S	Leg Bracket Condensing Heat Exch (2 pcs per boiler)	012628F	012629F	012630F
20-S	Base Reflector Panel	007307F	007307F	007307F
21-S	Flue Exhaust Adapter Assembly	012631F	012632F	012632F
39-S	Flue Exhaust Adapter Assembly PVC	013410F	013411F	013411F
22-S	Control Box Assy	012633F	012633F	012633F
23-S	Control Box Cover Panel w/Display	012634F	012634F	012634F
24-S	Control Box Cover Panel	012682F	012682F	012682F
25-S	Power Switch Mounting Panel	011872F	011872F	011872F
26-S	Blower/Pump Switch Mounting Panel	011873F	011873F	011873F
27-S	Controller Mounting Panel	011874F	011874F	011874F
28-S	CWR Control Mounting Panel	011978F	011978F	011978F
29-S	Control Box Blank Cover Long	012635F	012635F	012635F
30-S	Control Box Blank Cover Short	011870F	011870F	011870F
31-S	24V Wiring Panel	012636F	012636F	012636F
32-S	Intake Air Adapter (plenum to Duct)	N/A	N/A	011881F
33-S	Intake Air Collar	012675F	012676F	012676F
34-S	Access Panel Wiring Box	012651F	012651F	012651F
35-S	Access Panel Condensing Heat Exch	012638F	012638F	012638F
36-S	Plenum Upper Condensing Heat Exch	012639F	012640F	012641F
37-S	Plenum Lower Condensing Heat Exch	012642F	012643F	012644F
38-S	Filter Access Cover	012683F	012683F	012683F
40-S	Condensate Hose Bracket	013422F	013422F	013422F
V	VENTING			
1-V	Outdoor Stack	011894	011895	011895
2-V	Vent Cap Vertical for Indoor Units	010802	010803	010803
3-V	Vent Cap Horizontal Thru-the-Wall for Indoor Units	006644	006646	006646
4-V	Intake Air filter Box	012645F	012646F	012647F
5-V	Air Filter Media	012599F	012599F	012599F
6-V	Condensate Drip Pan	012678F	012678F	012678F
7-V	Flue Exhaust Adapter for PVC Venting	013346F	013347F	013347F
8-V	Flue Exhaust Adapter for Polypropylene Venting	013736	013737	013737



www.raypak.com